

SYLVANIA

SERVICE MANUAL

Sec. 1: Main Section

- Specifications
- Preparation for Servicing
- Adjustment Procedures
- Schematic Diagrams
- CBA's

Sec. 2: Deck Mechanism Section

- Standard Maintenance
- Alignment for Mechanism
- Disassembly/Assembly of Mechanism

Sec. 3: Exploded views and Parts List Section

- Exploded views
- Parts List

13" COLOR TV/VCR COMBINATION

SSC132

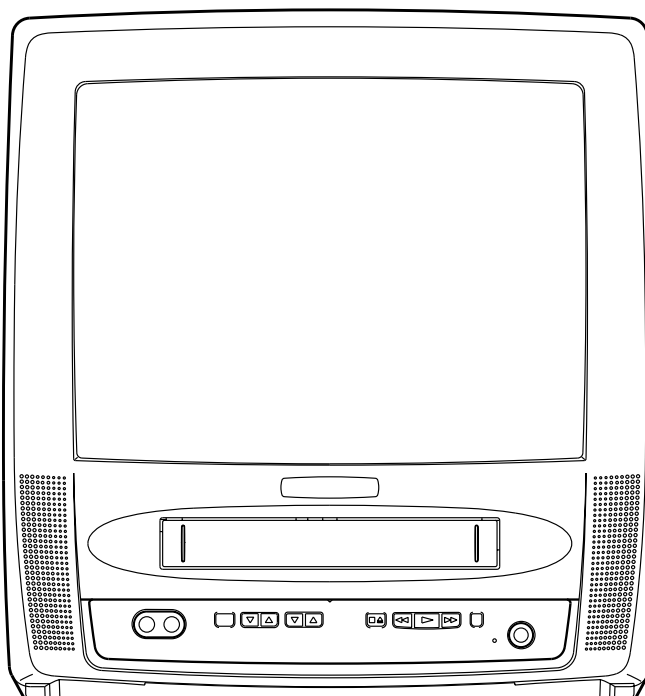

IMPORTANT SAFETY NOTICE

Proper service and repair is important to the safe, reliable operation of all Funai Equipment. The service procedures recommended by Funai and described in this service manual are effective methods of performing service operations. Some of these service special tools should be used when and as recommended.

It is important to note that this service manual contains various CAUTIONS and NOTICES which should be carefully read in order to minimize the risk of personal injury to service personnel. The possibility exists that improper service methods may damage the equipment. It also is important to understand that these CAUTIONS and NOTICES ARE NOT EXHAUSTIVE. Funai could not possibly know, evaluate and advice the service trade of all conceivable ways in which service might be done or of the possible hazardous consequences of each way. Consequently, Funai has not undertaken any such broad evaluation. Accordingly, a servicer who uses a service procedure or tool which is not recommended by Funai must first use all precautions thoroughly so that neither his safety nor the safe operation of the equipment will be jeopardized by the service method selected.

MAIN SECTION

13" COLOR TV/VCR COMBINATION

SSC132

- | |
|---|
| Sec. 1: Main Section <ul style="list-style-type: none">● Specifications● Preparation for Servicing● Adjustment Procedures● Schematic Diagrams● CBA's |
|---|

TABLE OF CONTENTS

Specifications	1-1-1
Important Safety Precautions	1-2-1
Standard Notes for Servicing	1-3-1
Preparation for Servicing	1-4-1
Operating Controls and Functions	1-5-1
Cabinet Disassembly Instructions	1-6-1
Electrical Adjustment Instructions	1-7-1
Block Diagrams	1-8-1
Mechanical Trouble Indicator	1-8-13
Power Supply Trouble Shooting Guide	1-8-15
Schematic Diagrams / CBA's and Test Points	1-9-1
Waveforms	1-10-1
Wiring Diagrams	1-11-1
System Control Timing Charts	1-12-1
IC Pin Function Descriptions	1-13-1
Lead Identifications	1-14-1

SPECIFICATIONS

✧ Mode-----SP mode unless otherwise specified

✧ Test input terminal

<Except Tuner>-----Video input (1Vp-p)
Audio input (-10dB)

<Tuner>-----Ant. input (80dB μ V) Video: 87.5%
Audio: 25kHz dev (1kHz Sin)

<DEFLECTION>

Description	Condition	Unit	Nominal	Limit
1. Over Scan	—	%	90	—
2. Linearity	Horizontal	%	—	15
	Vertical	%	—	10
3. High Voltage	—	kV	22	—

<VIDEO & CHROMA>

Description	Condition	Unit	Nominal	Limit
1. Misconvergence	Center	m/m	—	0.3
	Corner	m/m	—	1.5
	Side	m/m	—	1.2
2. Tint Control Range	—	deg	± 30	—
3. Contrast Control Range	—	dB	6	4
4. Brightness	APL 100%	ft-L	55	40
5. Color Temperature	—	K	9200	—

<VCR>

Description	Condition	Unit	Nominal	Limit
1. Horizontal Resolution	(R/P)	Line	230	200
2. Jitter (Low)	(R/P)	μ S	0.05	0.2
3. S/N Chroma	AM(SP)	(R/P)	dB	38
	PM(SP)	(R/P)	dB	36
4. Wow & Flutter (RMS)	(R/P)	%	0.25	0.5

<TUNER>

Description	Condition	Unit	Nominal	Limit
1. Video S/N	—	dB	45	40
2. Audio S/N (W/LPF)	—	dB	43	40

<AUDIO>

All items are measured across 8Ω resistor at speaker output terminal.

Description	Condition	Unit	Nominal	Limit
1. Audio Output Power (Max.)	(R/P)	W	1.0	0.8
2. Audio S/N (W/LPF)	(R/P)	dB	40	36
3. Audio Distortion (W/LPF)	(R/P)	%	3.0	5.0
4. Audio Freq. Response (-10dB Ref. 1KHz)	200Hz (R/P)	dB	-2.0	-2.0±5.0
	8kHz (R/P)	dB	0	0±6.0

Note: Nominal specifications represent the design specifications. All units should be able to approximate these. Some will exceed and some may drop slightly below these specifications. Limit specifications represent the absolute worst condition that still might be considered acceptable. In no case should a unit fail to meet limit specifications.

IMPORTANT SAFETY PRECAUTIONS

Prior to shipment from the factory, our products are strictly inspected for recognized product safety and electrical codes of the countries in which they are to be sold. However, in order to maintain such compliance, it is equally important to implement the following precautions when a set is being serviced.

Safety Precautions for TV Circuit

1. **Before returning an instrument to the customer**, always make a safety check of the entire instrument, including, but not limited to, the following items:

- a. Be sure that no built-in protective devices are defective and have been defeated during servicing.
(1) Protective shields are provided on this chassis to protect both the technician and the customer. Correctly replace all missing protective shields, including any removed for servicing convenience.
(2) When reinstalling the chassis and/or other assembly in the cabinet, be sure to put back in place all protective devices, including but not limited to, nonmetallic control knobs, insulating fishpapers, adjustment and compartment covers/shields, and isolation resistor/capacitor networks. **Do not operate this instrument or permit it to be operated without all protective devices correctly installed and functioning. Servicers who defeat safety features or fail to perform safety checks may be liable for any resulting damage.**
- b. Be sure that there are no cabinet openings through which an adult or child might be able to insert their fingers and contact a hazardous voltage. Such openings include, but are not limited to, (1) spacing between the picture tube and the cabinet mask, (2) excessively wide cabinet ventilation slots, and (3) an improperly fitted and/or incorrectly secured cabinet back cover.
- c. **Antenna Cold Check** - With the instrument AC plug removed from any AC source, connect an electrical jumper across the two AC plug prongs. Place the instrument AC switch in the on position. Connect one lead of an ohmmeter to the AC plug prongs tied together and touch the other ohmmeter lead in turn to each tuner antenna input exposed terminal screw and, if applicable, to the coaxial connector. If the measured resistance is less than 1.0 megohm or greater than 5.2 megohm, an abnormality exists that must be corrected before the instrument is returned to the customer. Repeat this test with the instrument AC switch in the off position.
- d. **Leakage Current Hot Check** - With the instrument completely reassembled, plug the AC line cord directly into a 120V AC outlet. (Do not use an isolation transformer during this test.) Use a leak-

age current tester or a metering system that complies with American National Standards Institute (ANSI) C101.1 Leakage Current for Appliances and Underwriters Laboratories (UL) 1410, (50.7). With the instrument AC switch first in the on position and then in the off position, measure from a known earth ground (metal water pipe, conduit, etc.) to all exposed metal parts of the instrument (antennas, handle brackets, metal cabinet, screw heads, metallic overlays, control shafts, etc.), especially any exposed metal parts that offer an electrical return path to the chassis. Any current measured must not exceed 0.5 milli-ampere. Reverse the instrument power cord plug in the outlet and repeat the test.

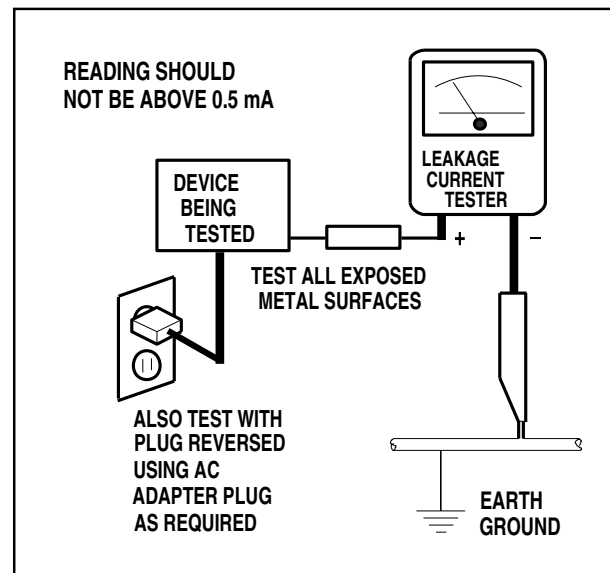

ANY MEASUREMENTS NOT WITHIN THE LIMITS SPECIFIED HEREIN INDICATE A POTENTIAL SHOCK HAZARD THAT MUST BE ELIMINATED BEFORE RETURNING THE INSTRUMENT TO THE CUSTOMER OR BEFORE CONNECTING THE ANTENNA OR ACCESSORIES.

- e. **X-Radiation and High Voltage Limits** - Because the picture tube is the primary potential source of X-radiation in solid-state TV receivers, it is specially constructed to prohibit X-radiation emissions. For continued X-radiation protection, the replacement picture tube must be the same type as the original. Also, because the picture tube shields and mounting hardware perform an X-radiation protection function, they must be correctly in place. High voltage must be measured each time servic-

ing is performed that involves B+, horizontal deflection or high voltage. Correct operation of the X-radiation protection circuits also must be reconfirmed each time they are serviced. (X-radiation protection circuits also may be called "horizontal disable" or "hold down.") Read and apply the high voltage limits and, if the chassis is so equipped, the X-radiation protection circuit specifications given on instrument labels and in the Product Safety & X-Radiation Warning note on the service data chassis schematic. High voltage is maintained within specified limits by close tolerance safety-related components/adjustments in the high-voltage circuit. If high voltage exceeds specified limits, check each component specified on the chassis schematic and take corrective action.

2. Read and comply with all caution and safety-related notes on or inside the receiver cabinet, on the receiver chassis, or on the picture tube.

3. **Design Alteration Warning** - Do not alter or add to the mechanical or electrical design of this TV receiver. Design alterations and additions, including, but not limited to circuit modifications and the addition of items such as auxiliary audio and/or video output connections, might alter the safety characteristics of this receiver and create a hazard to the user. Any design alterations or additions will void the manufacturer's warranty and may make you, the servicer, responsible for personal injury or property damage resulting therefrom.

4. **Picture Tube Implosion Protection Warning** - The picture tube in this receiver employs integral implosion protection. For continued implosion protection, replace the picture tube only with one of the same type number. Do not remove, install, or otherwise handle the picture tube in any manner without first putting on shatterproof goggles equipped with side shields. People not so equipped must be kept safely away while picture tubes are handled. Keep the picture tube away from your body. Do not handle the picture tube by its neck. Some "in-line" picture tubes are equipped with a permanently attached deflection yoke; because of potential hazard, do not try to remove such "permanently attached" yokes from the picture tube.

5. **Hot Chassis Warning** -

a. Some TV receiver chassis are electrically connected directly to one conductor of the AC power cord and maybe safety-serviced without an isolation transformer only if the AC power plug is inserted so that the chassis is connected to the ground side of the AC power source. To confirm that the AC power plug is inserted correctly, with an AC voltmeter, measure between the chassis and a known

earth ground. If a voltage reading in excess of 1.0V is obtained, remove and reinsert the AC power plug in the opposite polarity and again measure the voltage potential between the chassis and a known earth ground.

b. Some TV receiver chassis normally have 85V AC(RMS) between chassis and earth ground regardless of the AC plug polarity. This chassis can be safety-serviced only with an isolation transformer inserted in the power line between the receiver and the AC power source, for both personnel and test equipment protection.

c. Some TV receiver chassis have a secondary ground system in addition to the main chassis ground. This secondary ground system is not isolated from the AC power line. The two ground systems are electrically separated by insulation material that must not be defeated or altered.

6. Observe original lead dress. Take extra care to assure correct lead dress in the following areas: a. near sharp edges, b. near thermally hot parts-be sure that leads and components do not touch thermally hot parts, c. the AC supply, d. high voltage, and e. antenna wiring. Always inspect in all areas for pinched, out of place, or frayed wiring. Check AC power cord for damage.

7. Components, parts, and/or wiring that appear to have overheated or are otherwise damaged should be replaced with components, parts, or wiring that meet original specifications. Additionally, determine the cause of overheating and/or damage and, if necessary, take corrective action to remove any potential safety hazard.

8. **Product Safety Notice** - Some electrical and mechanical parts have special safety-related characteristics which are often not evident from visual inspection, nor can the protection they give necessarily be obtained by replacing them with components rated for higher voltage, wattage, etc.. Parts that have special safety characteristics are identified by a (▲) on schematics and in parts lists. Use of a substitute replacement that does not have the same safety characteristics as the recommended replacement part might create shock, fire, and/or other hazards. The Product's Safety is under review continuously and new instructions are issued whenever appropriate. Prior to shipment from the factory, our products are strictly inspected to confirm with the recognized product safety and electrical codes of the countries in which they are to be sold. However, in order to maintain such compliance, it is equally important to implement the following precautions when a set is being serviced.

Precautions during Servicing

- A.** Parts identified by the () symbol are critical for safety.
Replace only with part number specified.
- B.** In addition to safety, other parts and assemblies are specified for conformance with regulations applying to spurious radiation. These must also be replaced only with specified replacements.
Examples: RF converters, RF cables, noise blocking capacitors, and noise blocking filters, etc.
- C.** Use specified internal wiring. Note especially:
- 1) Wires covered with PVC tubing
 - 2) Double insulated wires
 - 3) High voltage leads
- D.** Use specified insulating materials for hazardous live parts. Note especially:
- 1) Insulation Tape
 - 2) PVC tubing
 - 3) Spacers
 - 4) Insulators for transistors.
- E.** When replacing AC primary side components (transformers, power cord, etc.), wrap ends of wires securely about the terminals before soldering.
- F.** Observe that the wires do not contact heat producing parts (heatsinks, oxide metal film resistors, fusible resistors, etc.)
- G.** Check that replaced wires do not contact sharp edged or pointed parts.
- H.** When a power cord has been replaced, check that 5~6 kg of force in any direction will not loosen it.
- I.** Also check areas surrounding repaired locations.
- J.** Use care that foreign objects (screws, solder drop-lets, etc.) do not remain inside the set.
- K.** Crimp type wire connector
When replacing the power transformer in sets where the connections between the power cord and power transformer primary lead wires are performed using crimp type connectors, in order to prevent shock hazards, perform carefully and precisely the following steps.
Replacement procedure
- 1) Remove the old connector by cutting the wires at a point close to the connector.
Important: Do not re-use a connector (discard it).
 - 2) Strip about 15 mm of the insulation from the ends of the wires. If the wires are stranded, twist the strands to avoid frayed conductors.
 - 3) Align the lengths of the wires to be connected. Insert the wires fully into the connector.
 - 4) Use the crimping tool to crimp the metal sleeve at the center position. Be sure to crimp fully to the complete closure of the tool.
- L.** When connecting or disconnecting the VCR connectors, first, disconnect the AC plug from AC supply socket.

Safety Check after Servicing

Examine the area surrounding the repaired location for damage or deterioration. Observe that screws, parts and wires have been returned to original positions. Afterwards, perform the following tests and confirm the specified values in order to verify compliance with safety standards.

1. Clearance Distance

When replacing primary circuit components, confirm specified clearance distance (d) and (d') between soldered terminals, and between terminals and surrounding metallic parts. (See Fig. 1)

Table 1 : Ratings for selected area

AC Line Voltage	Region	Clearance Distance (d) (d')
110 to 130 V	USA or CANADA	≥ 3.2 mm (0.126 inches)

Note: This table is unofficial and for reference only. Be sure to confirm the precise values.

2. Leakage Current Test

Confirm the specified (or lower) leakage current between B (earth ground, power cord plug prongs) and externally exposed accessible parts (RF terminals, antenna terminals, video and audio input and output terminals, microphone jacks, earphone jacks, etc.).

Measuring Method : (Power ON)

Insert load Z between B (earth ground, power cord plug prongs) and exposed accessible parts. Use an AC voltmeter to measure across both terminals of load Z . See Fig. 2 and following table.

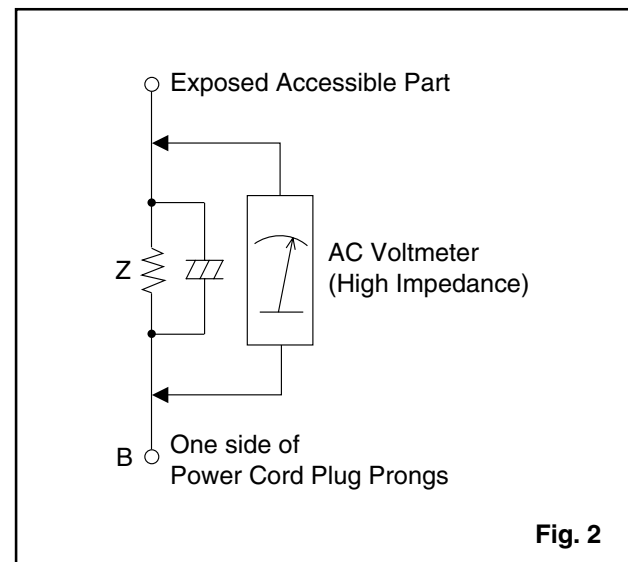
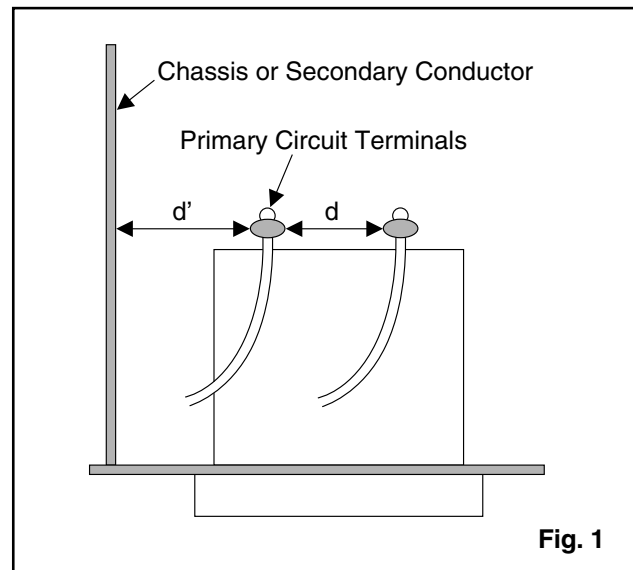

Table 2 : Leakage current ratings for selected areas

AC Line Voltage	Region	Load Z	Leakage Current (i)	Earth Ground (B) to:
110 to 130 V	USA or CANADA	0.15 μ F CAP. & 1.5k Ω RES. connected in parallel	$i \leq 0.5$ mA rms	Exposed accessible parts

Note: This table is unofficial and for reference only. Be sure to confirm the precise values.

STANDARD NOTES FOR SERVICING

Circuit Board Indications

1. The output pin of the 3 pin Regulator ICs is indicated as shown:

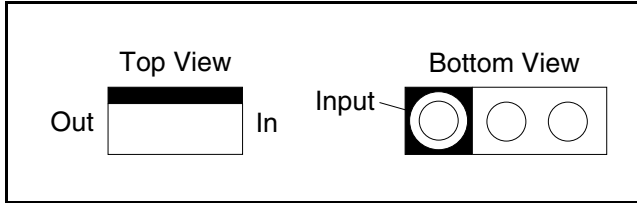

2. For other ICs, pin 1 and every 5th pin is indicated as shown:

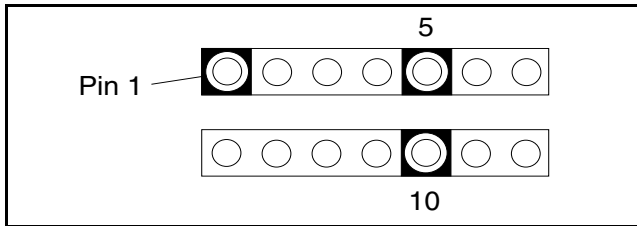

3. The 1st pin of every pin connector are indicated as shown:

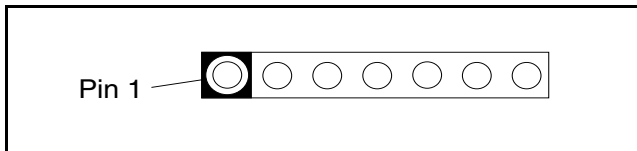

Instructions for Connectors

1. When you connect or disconnect FFC cable (connector), be sure to disconnect the AC cord.
2. FFC cable (connector) should be inserted parallel into the connector, not at an angle.

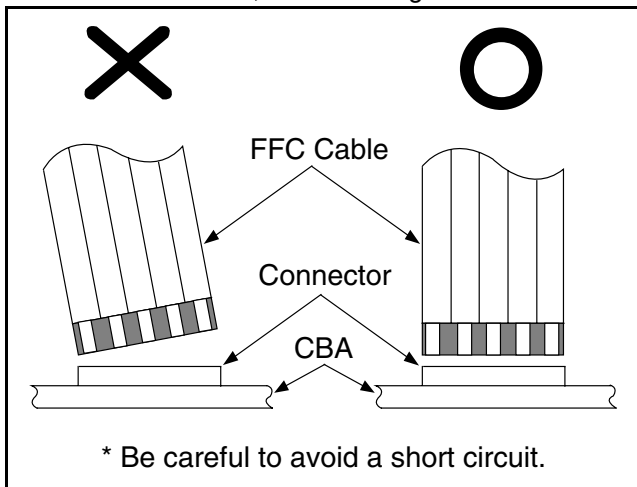

[CBA= Circuit Board Assembly]

How to Read the Values of the Rectangular Type Chip Components

Example:

(a) Resistor

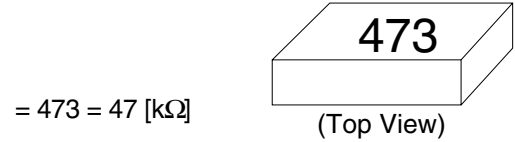

(b) Capacitor

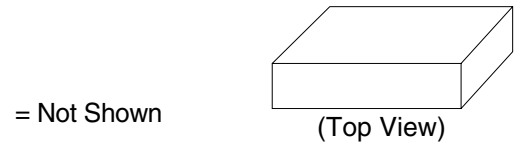

Caution:

Once chip parts (Resistors, Capacitors, Transistors, etc.) are removed, they must not be reused. Always use a new part.

Replacement Procedures for Leadless (Chip) Components

The Following Procedures are Recommended for the Replacement of the Leadless Components Used in this Unit.

1. Preparation for replacement

- a. Soldering Iron
Use a pencil-type soldering iron (less than 30 watts).
- b. Solder
Eutectic solder (Tin 63%, Lead 37%) is recommended.
- c. Soldering time
Do not apply heat for more than 4 seconds.
- d. Preheating
Leadless capacitor must be preheated before installation. (130°C~150°C, for about two minutes.)

Notes:

- a. Leadless components must not be reused after removal.
- b. Excessive mechanical stress and rubbing for the component electrode must be avoided.

2. Removing the leadless component

Grasp the leadless component body with tweezers and alternately apply heat to both electrodes. When the solder on both electrodes has melted, remove leadless component with a twisting motion.

Notes:

- a. Do not attempt to lift the component off the board until the component is completely disconnected from the board by the twisting action.
- b. Take care not to break the copper foil on the printed board

3. Installing the leadless component

- a. Presolder the contact points of the circuit board.
- b. Press the part downward with tweezers and solder both electrodes as shown below.

Note:

Do not glue the replacement leadless component to the circuit board.

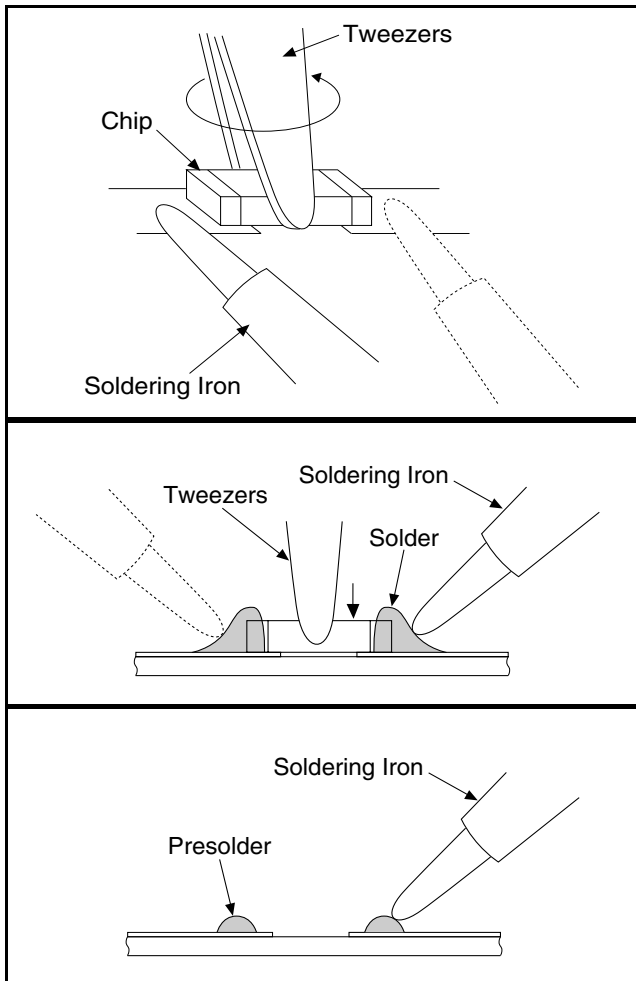

How to Remove / Install Flat Pack IC

Caution:

- 1. Do not apply the hot air to the chip parts around the Flat Pack-IC for over 6 seconds as damage may occur to the chip parts. Put Masking Tape around the Flat Pack-IC to protect other parts from damage. (Fig. S-1-2)

- 2. The Flat Pack-IC on the CBA is affixed with glue, so be careful not to break or damage the foil of each pin or solder lands under the IC when removing it.

1. Removal

With Hot - Air Flat Pack - IC Desoldering Machine:

- a. Prepare the Hot - Air Flat Pack - IC Desoldering Machine, then apply hot air to Flat Pack - IC (about 5~6 seconds). (Fig. S-1-1)
- b. Remove the Flat Pack- IC with tweezers while applying the hot air.

With Soldering Iron:

- a. Using desoldering braid, remove the solder from all pins of the Flat Pack - IC. When you use solder flux which is applied to all pins of the Flat Pack - IC, you can remove it easily. (Fig. S-1-3)
- b. Lift each lead of the Flat Pack - IC upward one by one, using a sharp pin or wire to which solder will not adhere (iron wire). When heating the pins, use a fine tip soldering iron or a hot air Desoldering Machine. (Fig. S-1-4)

With Iron Wire:

- a. Using desoldering braid, remove the solder from all pins of the Flat Pack - IC. When you use solder flux which is applied to all pins of the Flat Pack - IC, you can remove it easily. (Fig. S-1-3)
- b. Affix the wire to a workbench or solid mounting point, as shown in Fig. S-1-5.
- c. Pull up on the wire as the solder melts so as to lift the IC leads from the CBA contact pads, while heating the pins using a fine tip soldering iron or hot air blower.

Note:

When using a soldering iron, care must be taken to ensure that the Flat Pack - IC is not being held by glue, or when it is removed from the CBA, it may be damaged if force is used.

2. Installation

- a. Using desoldering braid, remove the solder from the foil of each pin of the Flat Pack - IC on the CBA, so you can install a replacement Flat Pack - IC more easily.
- b. The "●" mark on the Flat Pack - IC indicates pin 1 (See Fig. S-1-6). Make sure this mark matches the 1 on the CBA when positioning for installation. Then pre - solder the four corners of the Flat Pack-IC (See Fig. S-1-7).
- c. Solder all pins of the Flat Pack - IC. Make sure that none of the pins have solder bridges.

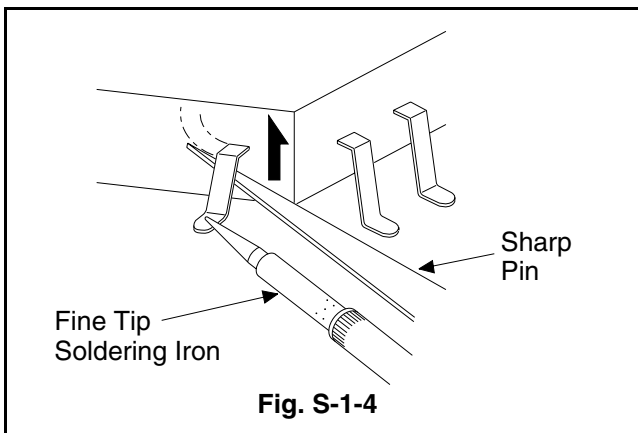
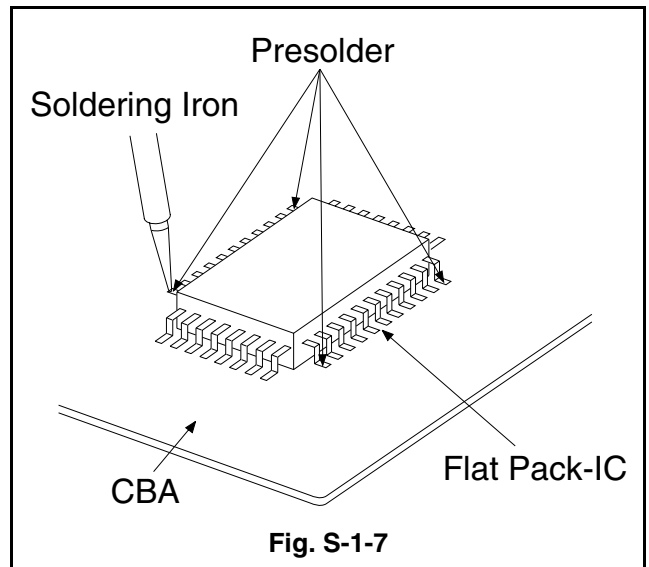
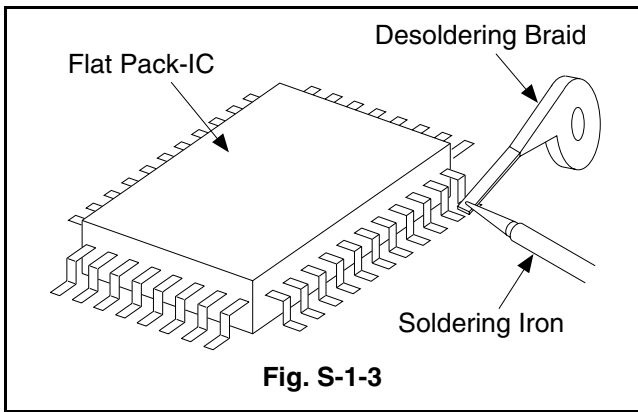
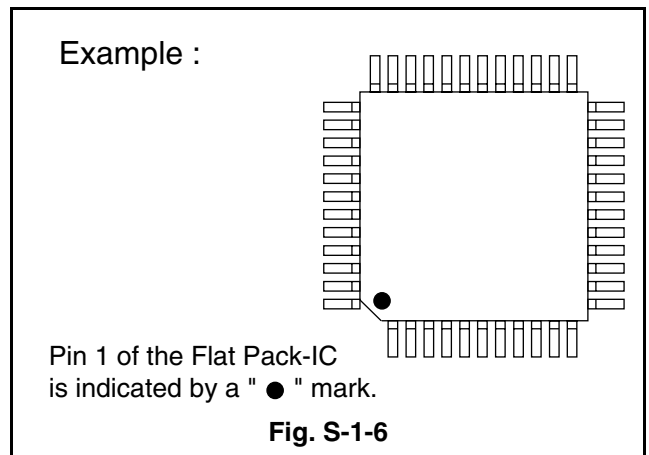
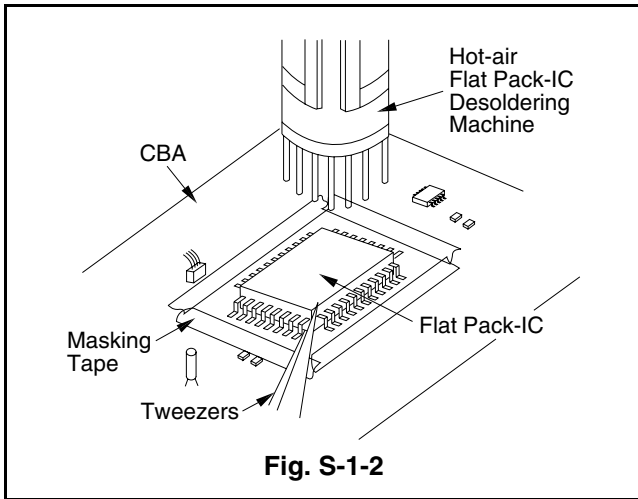
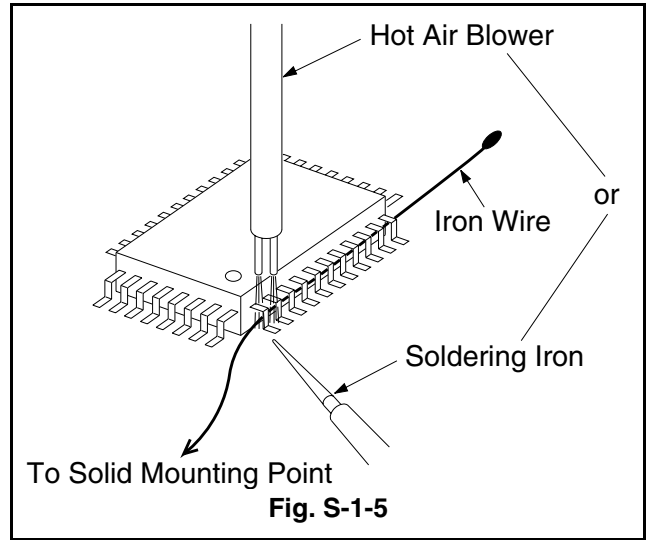
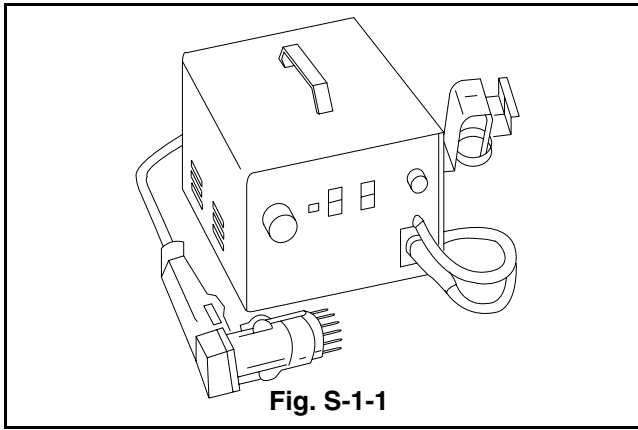

Instructions for Handling Semiconductors

Electrostatic breakdown of the semiconductors may occur due to a potential difference caused by electrostatic charge during unpacking or repair work.

Ground for Human Body

Be sure to wear a grounding band ($1M\Omega$) that is properly grounded to remove any static electricity that may be charged on the body.

Ground for Work Bench

Be sure to place a conductive sheet or copper plate with proper grounding ($1M\Omega$) on the work bench or other surface, where the semiconductors are to be placed. Because the static electricity charge on the clothing will not escape through the body grounding band, be careful to avoid contacting semiconductors to clothing.

Incorrect

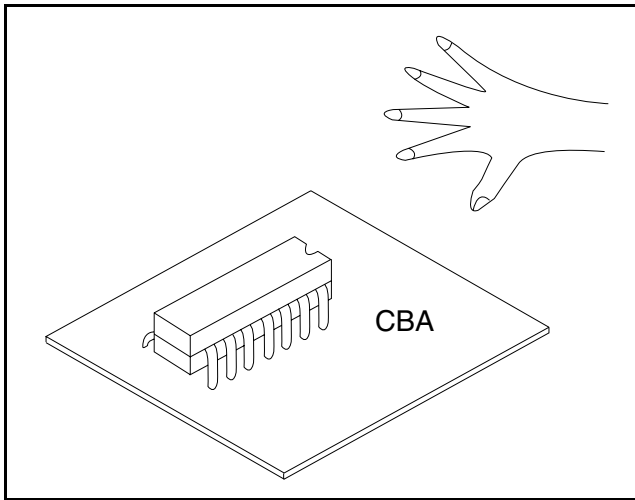

Correct

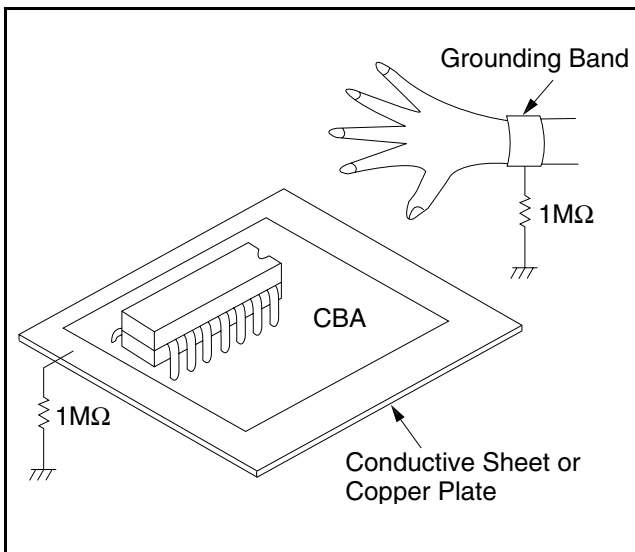

PREPARATION FOR SERVICING

How to Enter the Service Mode

Caution: 1

- Optical sensors system are used for Tape Start and End Sensor on this equipment. Read this page carefully and prepare as described on this page before starting to service; otherwise, the unit may operate unexpectedly.

Preparing: 1

- Cover Q202 (START SENSOR) and Q201 (END SENSOR) with Insulation Tape or enter the service mode to activate Sensor Inhibition automatically.

Note: Avoid playing, rewinding or fast forwarding the tape to its beginning or end, because both Tape End Sensors are not active.

How to Enter the Service Mode

- Turn power on.
- Use service remote control unit and press WAKE-UP/SLEEP key. (See page 1-7-1)
- When entering the service mode, one of the number (1, 2 or 4) will display at corners of the screen.
- During the service mode, electrical adjustment mode can be selected by remote control key. (Service remote control unit).

Details are as follows.

Key	Adjustment Mode
MENU	Picture adjustment mode: Press the MENU button to change from BRT (Bright), *CNT (Contrast), *CLR (Color), *TNT (Tint) and *V-T. Press CH UP/DOWN key to display Initial Value. *Marked items are not necessary to adjust normally.
0	C-Trap and Y DL Time adjustment mode: See adjustment instructions page 1-7-2.
1	No need to use.
2	AGC/H adjustment mode: See adjustment instructions page 1-7-2.
3	Auto AFT adjustment mode: See adjustment instructions page 1-7-1.
4	Auto record mode: Perform recording (15 Sec.)-->Stop-->Rewind (Zero return) automatically.
5	Head switching point adjustment mode: See adjustment instructions page 1-7-5.

Key	Adjustment Mode
6	No need to use.
7	Purity check mode: Shows Red, Green, Blue or White cyclically on the screen each time the "7" key is pressed.
8	H. Shift adjustment mode: See adjustment instructions page 1-7-4.
9	V.size/V. shift adjustment: See adjustment instructions page 1-7-3.

Caution: 2

- The deck mechanism assembly is mounted on the Main CBA directly, and SW211 (REC-SAFETY SW) is mounted on the Main CBA. When deck mechanism assembly is removed from the Main CBA due to servicing, this switch can not be operated automatically.

Preparing: 2

- To eject the tape, press the STOP/EJECT button on the unit (or Remote Control).
- When you want to record during the Service mode, press the Rec button while depressing SW211 (REC-SAFETY SW) on the Main CBA.

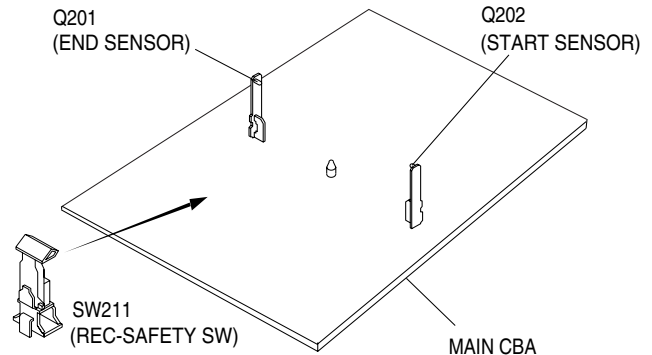

OPERATING CONTROLS AND FUNCTIONS

- TV/VCR FRONT PANEL -

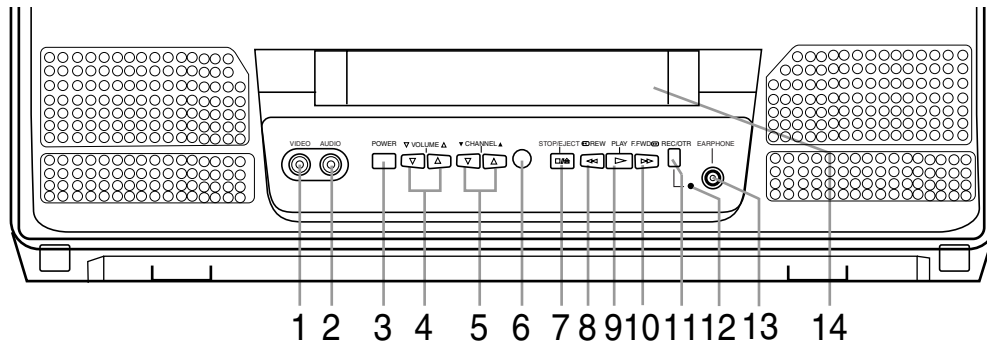

- REMOTE CONTROL -

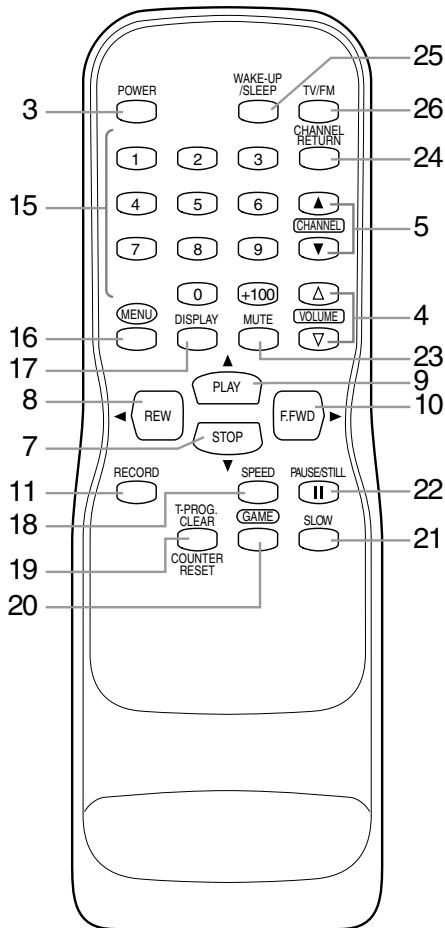

1 VIDEO input jack– Connect to the video output jack of your video camera or another VCR.

2 AUDIO input jack– Connect to the audio output jack of your audio equipment, video camera or another VCR.

3 POWER button– Press to turn TV/VCR on and off. Press to activate timer recording.

4 VOLUME Δ / ∇ buttons– Adjust the volume level.

5 CHANNEL Δ / ∇ buttons– Press to select the desired channels for viewing or recording, listening of FM radio.

You may display the main menu on the TV screen by pressing repeatedly this button on the TV/VCR.

TRACKING function– Press to minimize video ‘noise’ (lines or dots on screen) during playback or Slow mode.

6 Remote Sensor Window– Receives the infrared signals from the remote control.

7 STOP button– Press to stop the tape motion.

EJECT button– Press in the Stop mode to remove tape from TV/VCR.

∇ button–

- Press to select setting modes from the on screen menu.
- Press to enter digits when setting program. (for example: setting clock or timer program)

8 REW button– Press to rewind the tape, or to view the picture rapidly in reverse during playback mode. (Rewind Search)

\blacktriangleleft button–

- Press to select a mode from a particular menu. (for example: LANGUAGE or USER’S SET UP)

- REAR VIEW -

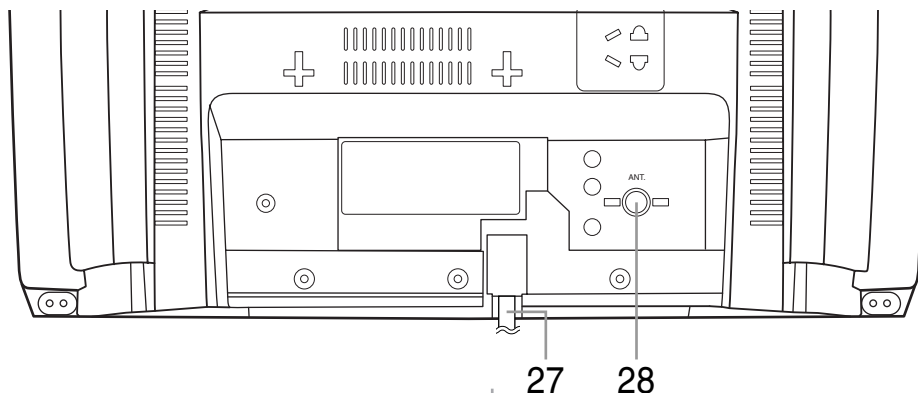

9 PLAY button– Press to begin playback.

▲ button–

- Press to select setting modes from the on screen menu.
- Press to enter digits when setting program. (for example: setting clock or timer program)

10 F.WD button– Press to rapidly advance the tape, or to view the picture rapidly in forward during playback mode. (Forward Search)

▶ button–

- When setting program (for example: setting clock or timer program), press to determine your selection and proceed to the next step you want to input.
- Press to determine setting modes from on screen menu.
- Press to select a mode from a particular menu. (for example: LANGUAGE or USER'S SET UP)

11 REC button– Press for manual recording.

OTR button– Activates One Touch Recording. (only on the TV/VCR)

12 RECORD indicator– Flashes during recording. Lights up in the Stand-by mode for Timer Recording.

13 EARPHONE jack– Connects to earphones (not supplied) for personal listening. The size of jack is 1/8" monaural (3.5mm).

14 Cassette compartment

15 Number buttons– Press to select desired channels for viewing or recording. To select channels from 1 to 9, first press the 0 button and then 1 to 9.

+100 button– When selecting cable channels which are higher than 99, press this button first, then press the last two digits. (To select channel 125, first press the "+100" button then press "2" and "5").

16 MENU button– Press to display the main menu on the TV screen.

17 DISPLAY button– Display the counter or the current channel number and current time on the TV screen.

27 28

18 SPEED button– Press to choose the desired recording speed:SP/SLP.

19 T-PROG. CLEAR button– Press to cancel a setting of timer program.

COUNTER RESET button– Press to reset counter to 0:00:00.

20 GAME button– Sets the game mode and external input mode at the same time.

21 SLOW button– Press to start slow motion playback.

22 PAUSE/STILL button– Press to temporarily stop the tape during the recording or to view a still picture during playback.

Frame Advance function– Press to advance the picture one frame at a time during Still mode.

23 MUTE button– Mutes the sound. Press it again to resume sound.

24 CHANNEL RETURN button– Press to go back to the previously viewed channel. For example, pressing this button once will change channel display from 3 (present channel) to 10 (previously viewed channel), and pressing it a second time will return from 10 to 3.

25 WAKE UP/SLEEP button– Sets the Wake up or Sleep Timer.

26 TV/FM button– Set the FM mode.

27 Power cord– Connect to a standard AC outlet (120V/60Hz).

28 ANT. terminal– Connect to an antenna or cable system.

CABINET DISASSEMBLY INSTRUCTIONS

1. Disassembly Flowchart

This flowchart indicates the disassembly steps for the cabinet parts, and the CBA in order to gain access to item(s) to be serviced. When reassembling, follow the steps in reverse order. Bend, route and dress the cables as they were.

Caution !!

When removing the CRT, be sure to discharge the Anode Lead of the CRT with the CRT Ground Wire before removing the Anode Cap.

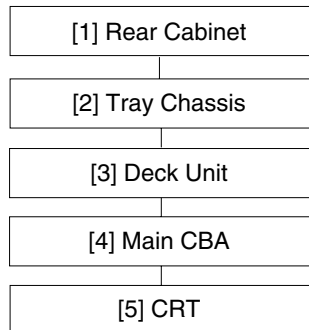

2. Disassembly Method

ID/ LOC. No.	PART	REMOVAL		
		Fig. No.	REMOVE/ *UNHOOK/ UNLOCK/RELEASE/ UNPLUG/DESOL- DER	Note
[1]	Rear Cabinet	1, 2	4(S-1)	1
[2]	Tray Chassis	3, 5	Anode Cap, CN501, CRT CBA, CN601, CN802, CN571	2
[3]	Deck Unit	3, 5	7(S-2), 2(S-3), Desolder (CL201, CL401, CL402, CL403)	3
[4]	Main CBA	3, 5	6(S-4)	4
[5]	CRT	4	4(S-5)	5

↓ ↓ ↓ ↓ ↓
 (1) (2) (3) (4) (5)

(1): Order of steps in Procedure. When reassembling, follow the steps in reverse order. These numbers are also used as the identification (location) No. of parts in Figures.

(2): Parts to be removed or installed.

(3): Fig. No. showing Procedure of Part Location.

(4): Identification of part to be removed, unhooked, unlocked, released, unplugged, unclamped, or desoldered.

S=Screw, P=Spring, L=Locking Tab, CN=Connector, *=Unhook, Unlock, Release, Unplug, or Desolder

2(S-2) = two Screw (S-2)

(5): Refer to the following "Reference Notes in the Table."

Reference Notes in the Table

1. Removal of the Rear Cabinet.

Remove Screws 4(S-1).

Caution !!

Discharge the Anode Lead of the CRT with the CRT Ground Wire before removing the Anode Cap.

2. Removal of the Tray Chassis.

Discharge the Anode Lead of the CRT with the CRT Ground before removing the Anode Cap.

Disconnect the following: Anode Cap, CN501, CRT CBA, CN601, CN571 and CN802. Then, pull the Tray Chassis backward.

3. Removal of the Deck Unit.

Remove Screws 7(S-2) and 2(S-3). Then, desolder connectors (CL201, CL401, CL402, CL403) and lift up the Deck Unit.

4. Removal of the Main CBA.

Remove Screws 6(S-4) and pull up the Main CBA.

5. Removal of the CRT.

Remove Screws 4(S-5) and pull the CRT backward.

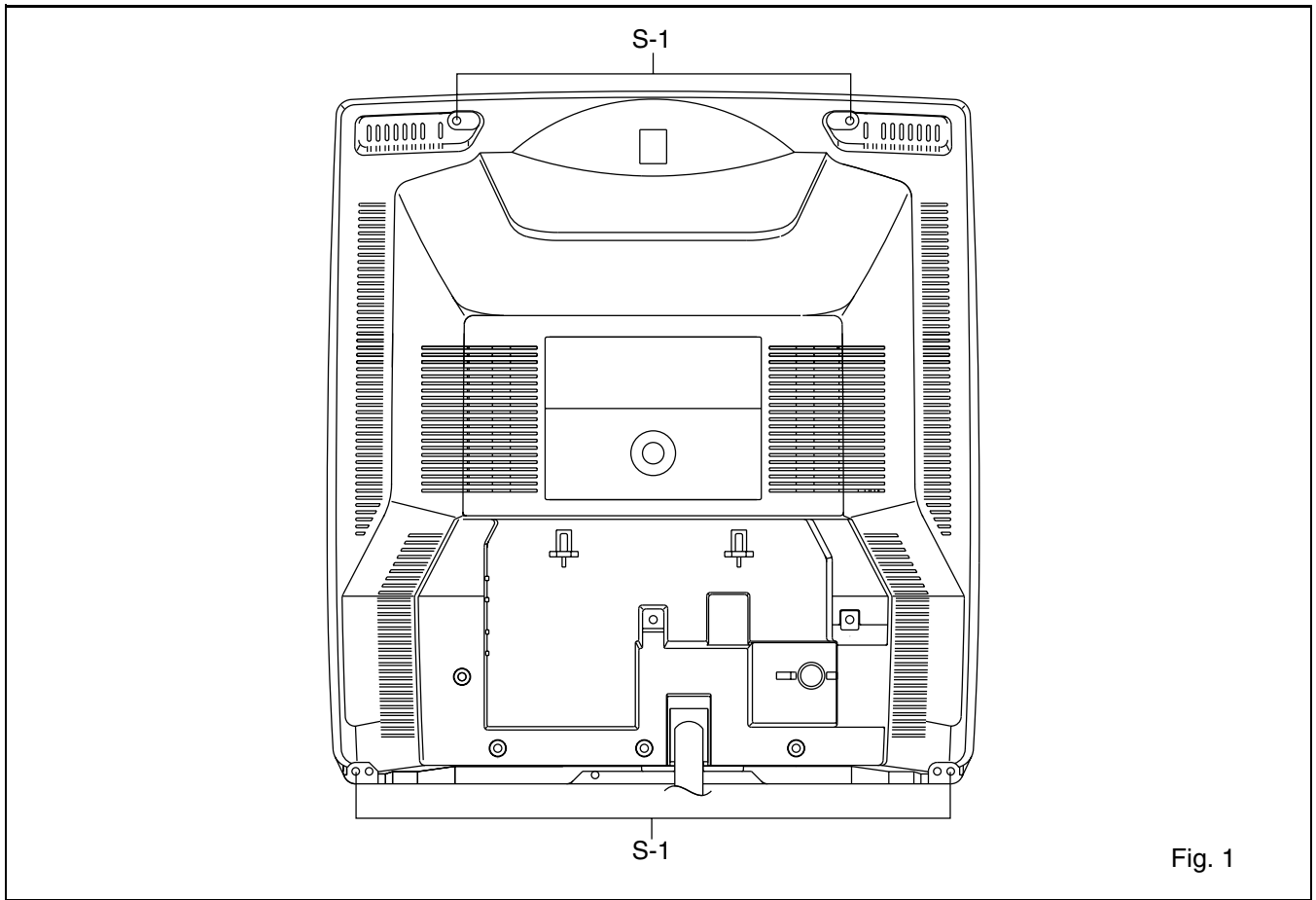

Fig. 1

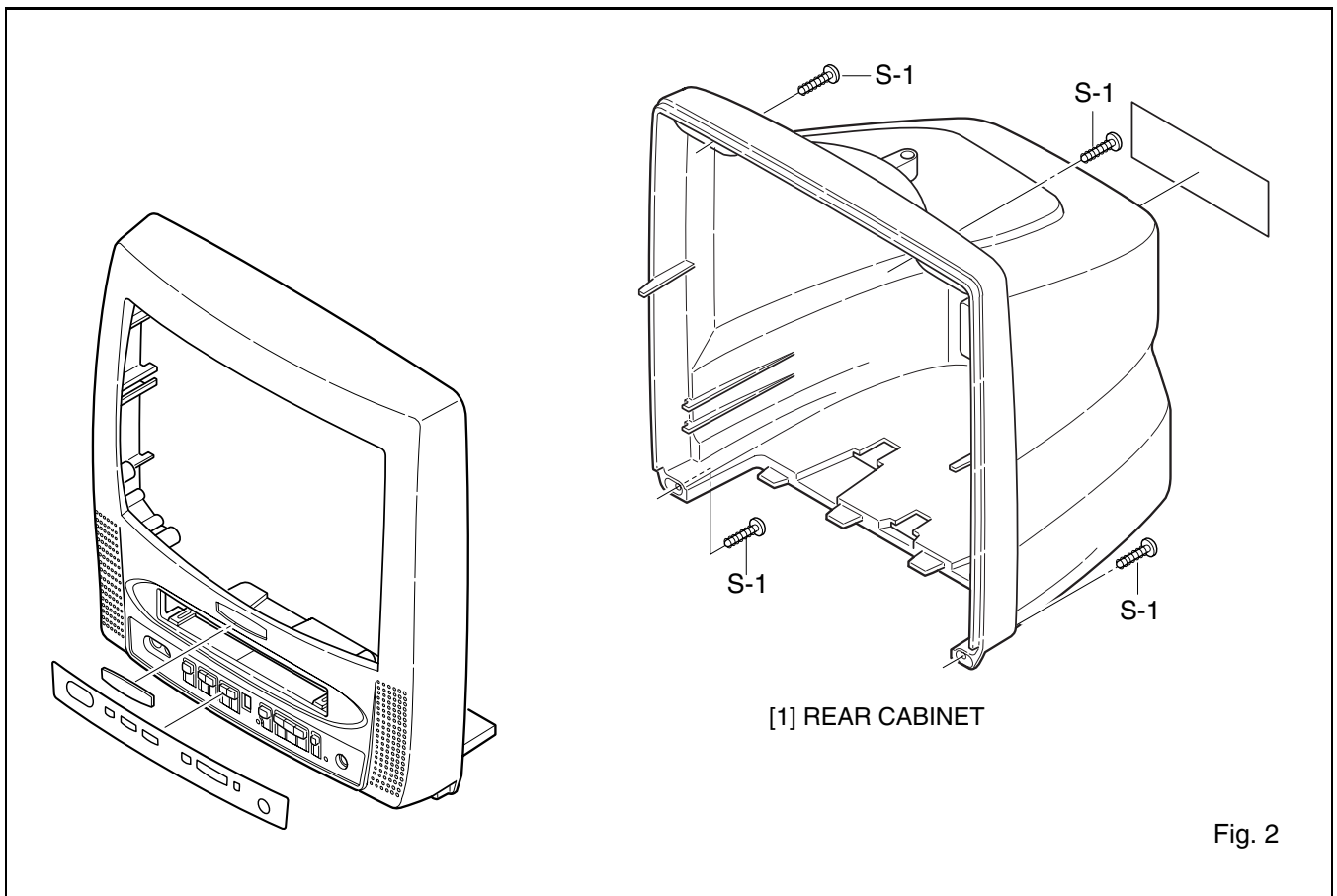

Fig. 2

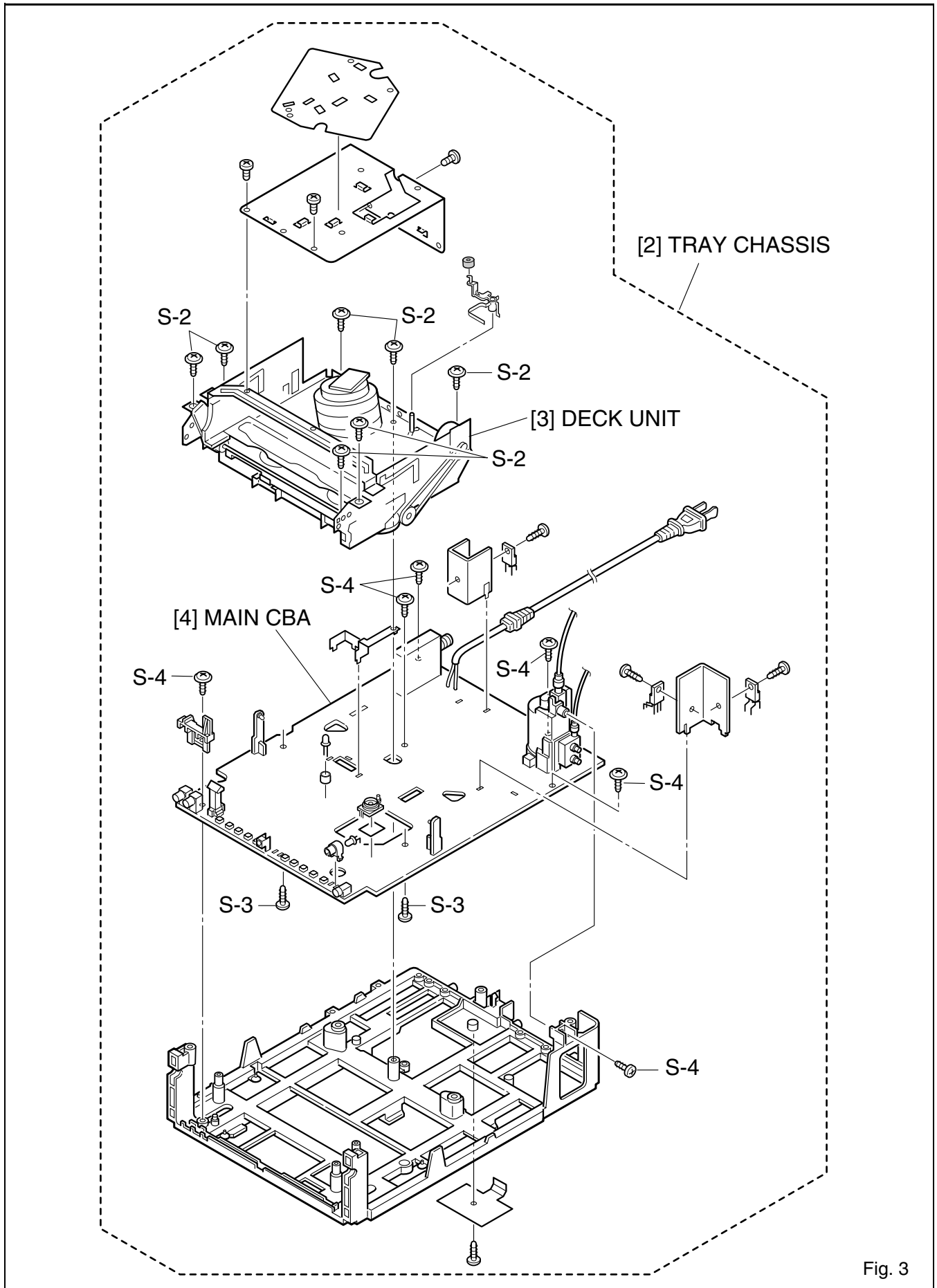

Fig. 3

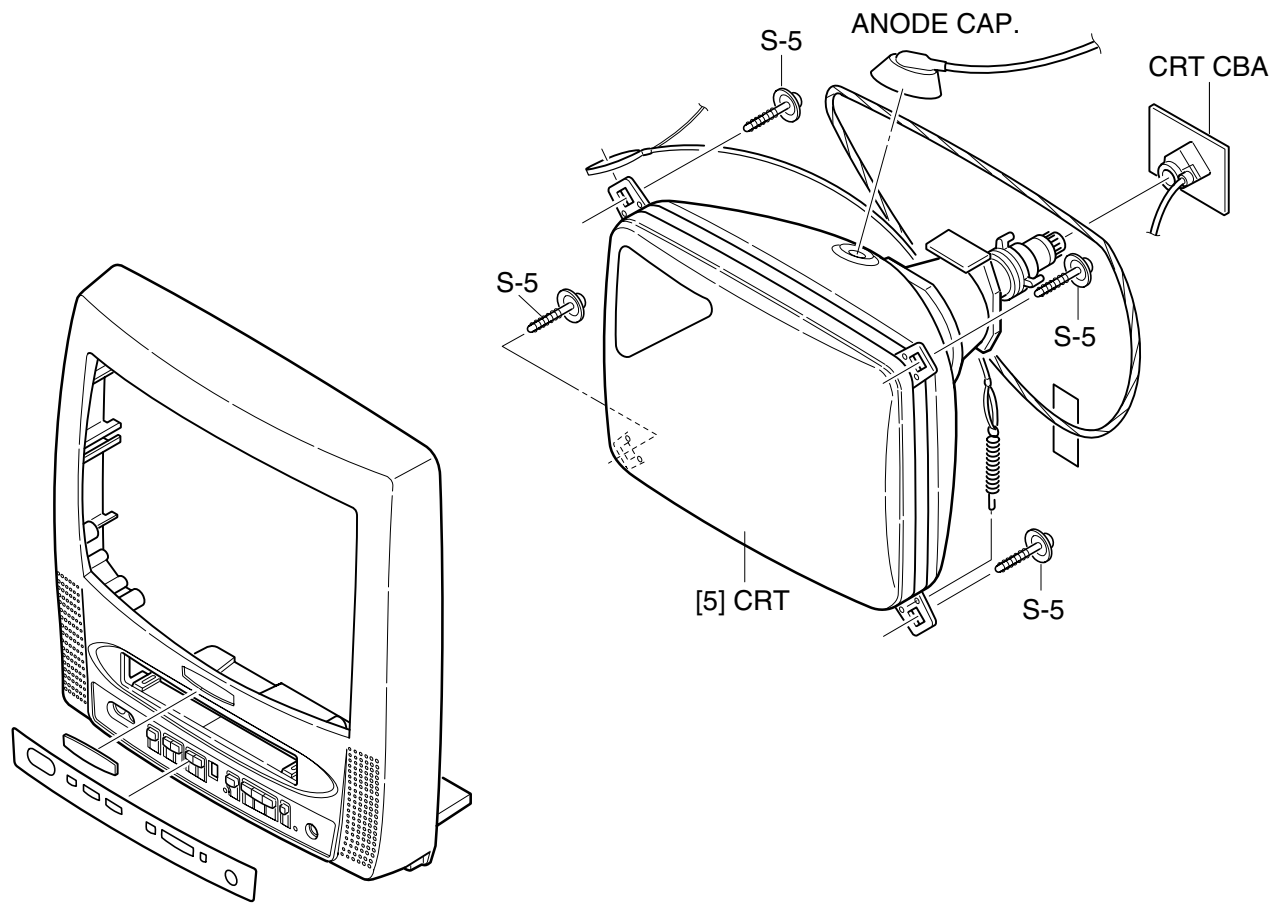

Fig. 4

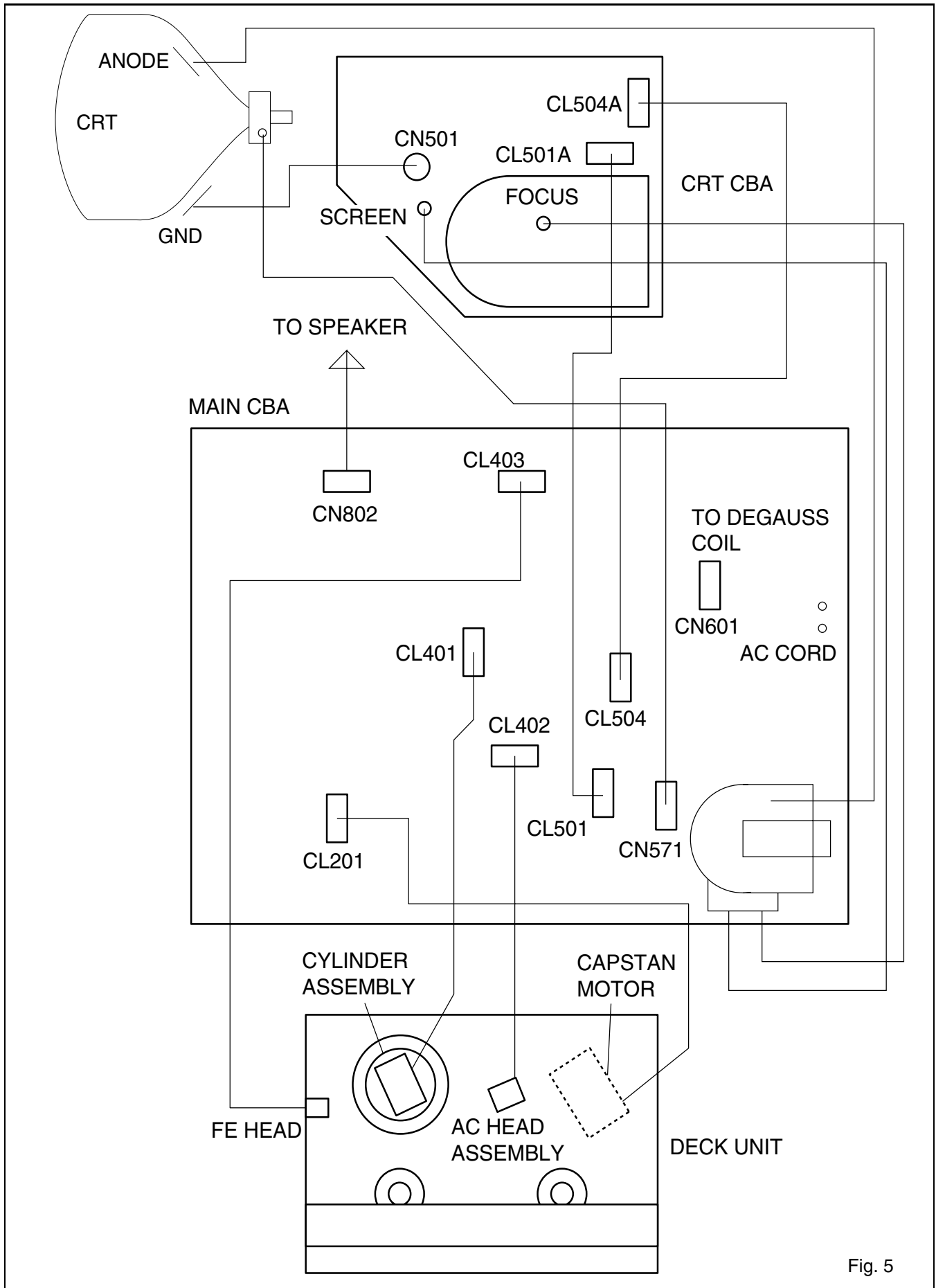

Fig. 5

ELECTRICAL ADJUSTMENT INSTRUCTIONS

General Note:

"CBA" is abbreviation for "Circuit Board Assembly."

NOTE:

Electrical adjustments are required after replacing circuit components and certain mechanical parts. It is important to perform these adjustments only after all repairs and replacements have been completed.

Also, do not attempt these adjustments unless the proper equipment is available.

Test Equipment Required

1. NTSC Pattern Generator (Color Bar W/White Window, Red Color, Dot Pattern, Gray Scale, Monoscope, Multi-Burst)
2. AC Milli Voltmeter (RMS)
3. Alignment Tape (FL8A, FL8N), Blank Tape
4. DC Voltmeter
5. Oscilloscope: Dual-trace with 10:1 probe, V-Range: 0.001~50V/Div, F-Range: DC~AC-60MHz
6. Frequency Counter
7. Plastic Tip Driver

How to make service remote control unit:

1. Prepare normal remote control unit. (Part No. N0107UD) Remove 3 screws from the back lid. (Fig. 1-1)
2. Added J1 (Jumper Wire) to the remote control CBA. (Fig. 1-2)

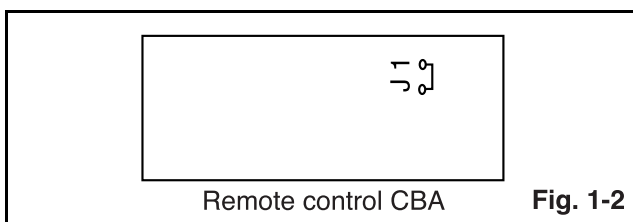
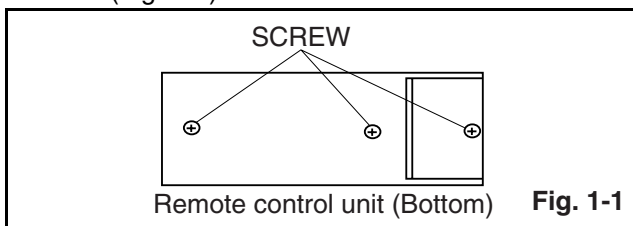

How to Set up the Service mode:

Service Mode:

1. Use the service remote control unit.
2. Turn the power on.
3. Press " WAKE-UP/SLEEP " button on the service remote control unit.

1. DC 105V (+B) Adjustment

Purpose: To obtain correct operation.

Symptom of Misadjustment: The picture is dark and unit does not operate correctly.

Test point	Adj. Point	Mode	Input
J192 (+B) J213 (GND)	VR601	---	-----
Tape	M. EQ.	Spec.	
---	DC Voltmeter Plastic Tip Driver	+105±0.5V DC	

Note: J192(+B), J213(GND), VR601 --- Main CBA

1. Connect the unit to AC Power Outlet.
2. Connect DC Volt Meter to J192(+B) and J213(GND).
3. Adjust VR601 so that the voltage of J192(+B) becomes +105±0.5V DC.

2. Auto AFT (VCO) Adjustment

Purpose: To operate AFT correctly.

Symptom of Misadjustment: AFT does not work correctly and/or synchronization is faulty.

Test point	Adj. Point	Mode	Input
---	---	Video	-----
Tape	M. EQ.	Spec.	
---	---	---	

1. Set the unit to the Video mode with no signal input.
2. Enter the Service mode. (See page 1-4-1.) Then press number "3" button on the remote control unit.
3. If the screen color changes to "Green" then this adjustment is finished.
4. If the screen color changes to "Red" then this adjustment is failed. Repeat steps 1 and 2 or check relative circuit or parts (IC).

3. TV AGC Adjustment

Purpose: Set AGC (Auto Gain Control) Level.

Symptom of Misadjustment: AGC does not synchronize correctly when RF input level is too weak and picture distortion may occur if it is too strong.

Test point	Adj. Point	Mode	Input
J191 (AGC)	CH. ▲ / ▼ buttons	---	Color Bar 67.25MHz 60dBμV
Tape	M. EQ.	Spec.	
---	Pattern Generator DC Voltmeter	+2.8±0.3V DC	

Note: J191 (AGC) --- Main CBA

1. Enter the Service mode. (See page 1-4-1.) Then press number 2 button on the remote control unit.
2. Receive the Color Bar signal for channel 4 (67.25MHz). (RF Input Level: 60dBμV)
3. Press CH. ▲ / ▼ buttons so that the voltage of J191 (AGC) becomes +2.8V±0.3V DC.
4. Turn the power off and on again.

4-1. H Adjustment

Purpose: To get correct horizontal position and size of screen image.

Symptom of Misadjustment: Horizontal position and size of screen image may not be properly displayed.

Test point	Adj. Point	Mode	Input
R583	CH ▲ / ▼ buttons	Video	---
Tape	M. EQ.	Spec.	
---	Frequency Counter	15.734kHz±300Hz	

Note: R583 --- Main CBA

1. Connect Frequency Counter to R583.
2. Set the unit to the VIDEO mode and no input is necessary. Enter the Service mode. (See page 1-4-1.)
3. Operate the unit for at least 20 minutes.
4. Press "2" button on the remote control unit and select H-Adj Mode. (Press "2" button, then display will change H-Adj and AGC.)
5. Press CH ▲ / ▼ buttons on the remote control unit so that the display will change "0" to "7."
At this moment, choose display "0" to "7" when the Frequency counter display is closest to 15.734kHz±300Hz.
6. Turn the power off and on again.

4-2. C-Trap Adjustment

Purpose: To get minimum leakage of the color signal carrier.

Symptom of Misadjustment: If C-Trap Adjustment is incorrect, stripes will appear on the screen.

Test point	Adj. Point	Mode	Input
J233 (B-OUT)	CH ▲ / ▼ buttons	---	Color Bar
Tape	M. EQ.	Spec.	
---	Oscilloscope Pattern Generator	---	

Figure

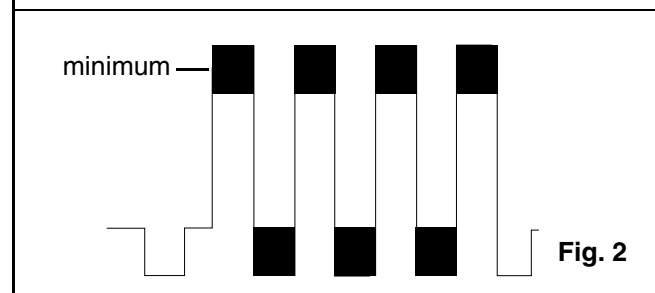

Note: J233 (B-Out)--- Main CBA

1. Connect Oscilloscope to J233.
2. Input a color bar signal from RF input. Enter the Service mode. (See page 1-4-1.)
3. Press "0" button on the remote control unit and select C-TRAP Mode.
4. Press CH ▲ / ▼ buttons on the remote control unit so that the carrier leakage B-Out (3.58MHz) value becomes minimum on the oscilloscope.
5. Turn the power off and on again.

4-3. Y DL Time Adjustment

Purpose: To get minimum leakage of the color signal carrier.

Symptom of Misadjustment: If Y DL Time Adjustment is incorrect, stripes will appear on the screen.

1. Enter the Service mode. (See page 1-4-1.)
2. Press "0" button on the remote control unit twice to show "D-T" on the display.
3. Select "2" by pressing CH ▲ / ▼ buttons on the remote control to enter Y DL Time Adjustment mode.
4. If needed, perform the following.

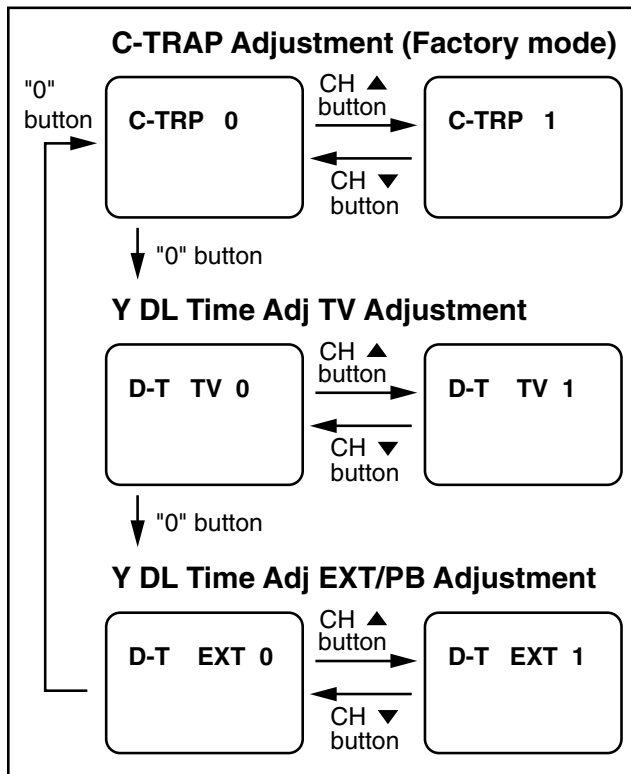

5. V. Size Adjustment

Purpose: To obtain correct vertical height of screen image.

Symptom of Misadjustment: If V. Size is incorrect, vertical height of image on the screen may not be properly displayed.

Test point	Adj. Point	Mode	Input
---	CH ▲ / ▼ buttons	---	Monoscope
Tape	M. EQ.	Spec.	
---	Pattern Generator	90±5%	

1. Enter the Service mode. (See page 1-4-1.)
Press "9" button on the remote control unit and select V-S Mode. (Press "9" button then display will change to V-P and V-S).
2. Input monoscope pattern.
3. Press CH ▲ / ▼ buttons on the remote control unit so that the monoscope pattern is 90±5% of display size and the circle is round.

6. V. Shift Adjustment

Purpose: To obtain correct vertical position of screen image.

Symptom of Misadjustment: If V. position is incorrect, vertical position of image on the screen may not be properly displayed.

Test point	Adj. Point	Mode	Input
---	CH ▲ / ▼ buttons	---	Monoscope
Tape	M. EQ.	Spec.	
---	Pattern Generator	90±5%	

1. Enter the Service mode. (See page 1-4-1.)
Press "9" button on the remote control unit and select V-P Mode. (Press "9" button then display will change to V-P and V-S).
2. Input monoscope pattern.
3. Press CH ▲ / ▼ buttons on the remote control unit so that the top and bottom of the monoscope pattern are equal to each other.

7. H. Shift Adjustment

Purpose: To obtain correct horizontal position and size of screen image.

Symptom of Misadjustment: Horizontal position and size of screen image may not be properly displayed.

Test point	Adj. Point	Mode	Input
---	CH ▲ / ▼ buttons	---	Monoscope
Tape	M. EQ.		Spec.
---	Pattern Generator		90±5%

1. Enter the Service mode. (See page 1-4-1.) Press "8" button on the remote control unit and select H-P Mode.
2. Input monoscope pattern.
3. Press CH ▲ / ▼ buttons on the remote control unit so that the left and right side of the monoscope pattern are equal to each other.
4. Turn the power off and on again.

8. Cut-off Adjustment

Purpose: To adjust the beam current of R, G, B, and screen voltage.

Symptom of Misadjustment: White color may be reddish, greenish or bluish.

Test point	Adj. Point	Mode	Input
---	Screen-Control	Ext.	Black Raster / White Raster
Tape	M. EQ.		Spec.
---	Pattern Generator		See Reference Notes below

Figure

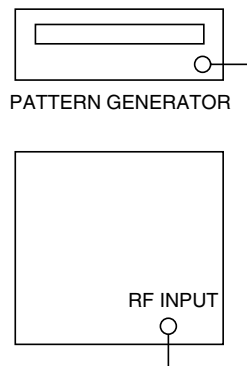

Fig. 3

Notes: Screen Control FBT --- MAIN CBA
F.B.T= Fly Back Transformer
Use the Remote Control Unit

1. Degauss the CRT and allow CRT to operate for 20 minutes before starting the alignment.
2. Set the screen control to minimum position. Input the Black raster signal from RF input.
3. Enter the Service Mode. (See page 1-4-1.) Dimmed horizontal line appears on the CRT.
4. Press the "VOL ▼" button. (Press "VOL ▼" then display will change CUT OFF/DRIVE, VCO adjustment, Analog OSD adjustment).
5. Choose CUT OFF/DRIVE Mode then press "1" button. This adjustment mode is CUT OFF (R).
6. Press the "CH ▲ / ▼" button until the horizontal line becomes white.
7. Choose CUT OFF/DRIVE mode then press "2" button. This adjustment mode is CUT OFF (G). Press "CH ▲ / ▼" until the horizontal line becomes white.
8. Choose CUT OFF/DRIVE Mode then press "3" button. This adjustment mode is CUT OFF (B). Press "CH ▲ / ▼" until the horizontal line becomes white.
9. Input the White Raster Signal from Video In.
10. Choose CUT OFF/DRIVE mode then press "4." Adjust the RED DRIVE as needed with the CH ▲ / ▼ buttons to get the following value, X= 286, Y= 294.
11. Choose CUT OFF/DRIVE mode then press "5." Adjust the BLUE DRIVE as needed with the CH ▲ / ▼ buttons to get the following value, X= 286.
12. Turn the power off and on again.

9. Sub-Brightness Adjustment

Purpose: To get proper brightness.

Symptom of Misadjustment: If Sub-Brightness is incorrect, proper brightness cannot be obtained by adjusting the Brightness Control.

Test point	Adj. Point	Mode	Input
---	CH ▲ / ▼ buttons	---	SYMPTE 7.5IRE
Tape	M. EQ.	Spec.	
---	Pattern Generator	See below	

Figure

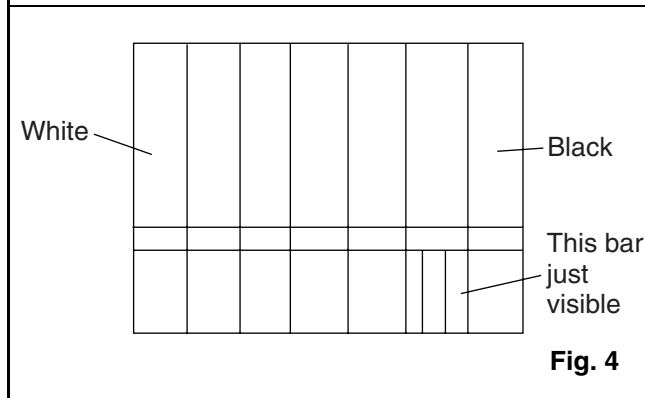

Fig. 4

Note: SYMPTE Setup level --- 7 IRE

1. Enter the Service Mode. (See page 1-4-1.) Then input SYMPTE signal from RF input.
2. Press MENU button. (Press MENU button then display will change B R T, C N T, T N T, V-T and SHP). Select BRT and press CH ▲ / ▼ buttons so that the bar is just visible (See above figure).
3. Turn the power off and on again.

10. Focus Adjustment

Purpose: Set the optimum Focus.

Symptom of Misadjustment: If Focus Adjustment is incorrect, blurred images are shown on the display.

Test point	Adj. Point	Mode	Input
---	Focus Control	---	Monoscope
Tape	M. EQ.	Spec.	
---	Pattern Generator	See below.	

Note: Focus VR (FBT) --- MAIN CBA

FBT= Fly Back Transformer

1. Operate the unit more than 30 minutes.
2. Face the unit to the East and degauss the CRT using a Degaussing Coil.
3. Input the monoscope pattern.
4. Adjust the Focus Control on the FBT to obtain clear picture.

11. Head Switching Position Adjustment

Purpose: Determine the Head Switching Point during Play back.

Symptom of Misadjustment: May cause Head Switching Noise or Vertical Jitter in the picture.

Note: Unit reads Head Switching Position automatically and displays it on the screen (Upper Left Corner).

1. Playback test tape (FL8A, FL8N).
2. Enter the Service Mode. (See page 1-4-1.) Then press the number 5 button on the remote control unit.
3. The Head Switching position will display on the screen; if adjustment is necessary follow step 4. 6.5H(412.7μs) is preferable.
4. Press "CH ▲" or "CH ▼" button on the remote control unit if necessary. The value will be changed in 0.5H steps up or down. Adjustable range is up to 9.5H. If the value is beyond adjustable range, the display will change as:
Lower out of range: 0.0H
Upper out of range: --H
5. Turn the power off and on again.

12. CCS Text Box Location

When replacing the CRT, the CCS Box might not stay in appropriate position. Then, replace micro computer.

Note: This adjustment automatically done by the microcomputer.

The following 2 adjustments normally are not attempted in the field. They should be done only when replacing the CRT then adjust as a preparation.

13. Purity Adjustment

Purpose: To obtain pure color.

Symptom of Misadjustment: If Color Purity Adjustment is incorrect, large areas of color may not be properly displayed.

Test point	Adj. Point	Mode	Input
---	Deflection Yoke Purity Magnet	---	*Red Color
Tape	M. EQ.	Spec.	
---	Pattern Generator	See below.	

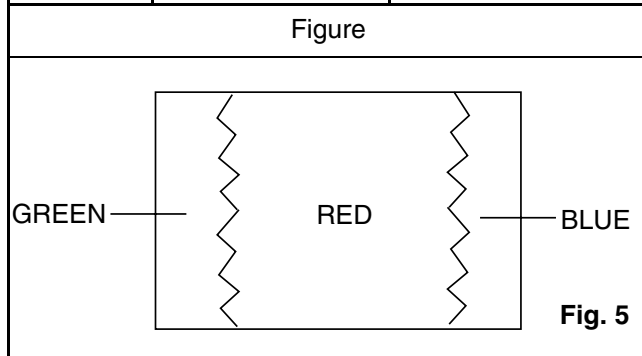

* This becomes RED COLOR if push 7KEY with a service mode.

1. Set the unit facing east.
2. Operate the unit for over 30 minutes before adjusting.
3. Fully degauss the unit using an external degaussing coil.
4. Set the unit to the AUX Mode which is located before CH2 then input a red raster from video in.
5. Loosen the screw on the Deflection Yoke Clamper and pull the Deflection Yoke back away from the screen. (See Fig. 6.)
6. Loosen the Ring Lock and adjust the Purity Magnets so that a red field is obtained at the center of the screen. Tighten Ring Lock. (See Fig. 5,6.)
7. Slowly push the Deflection Yoke toward the bell of the CRT and set it where a uniform red field is obtained.
8. Tighten the clamp screw on the Deflection Yoke.

14. Convergence Adjustment

Purpose: To obtain proper convergence of red, green and blue beams.

Symptom of Misadjustment: If Convergence Adjustment is incorrect, the edge of white letters may have color edges.

Test point	Adj. Point	Mode	Input
---	C.P. Magnet (RB), C.P. Magnet (RB-G), Deflection Yoke	---	Dot Pattern or Crosshatch
Tape	M. EQ.	Spec.	
---	Pattern Generator	See below.	

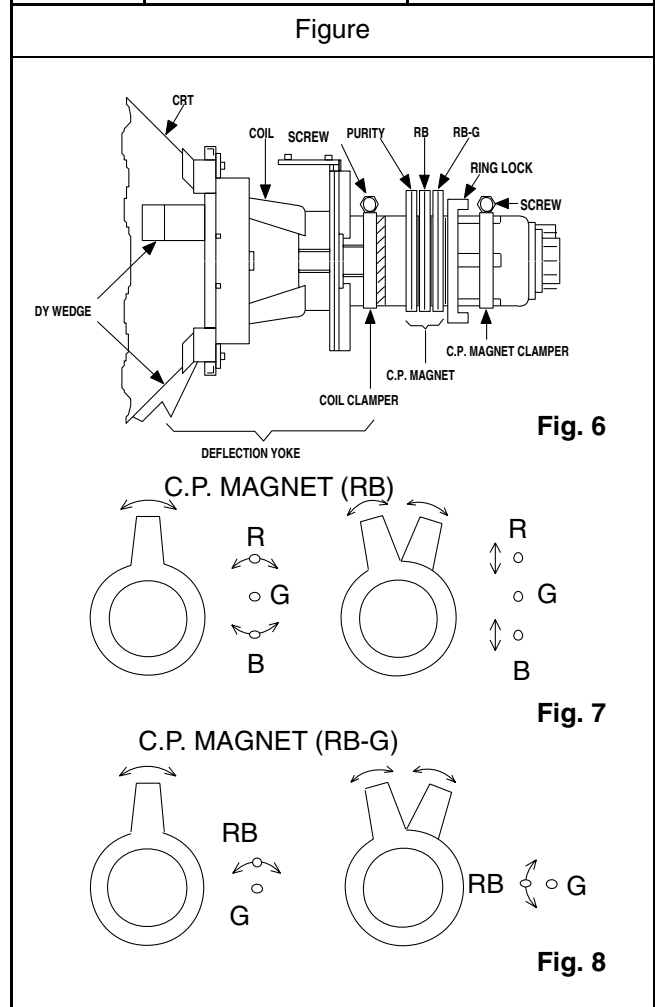

1. Set the unit to the AUX Mode which is located before CH2 then input a Dot or crosshatch pattern.
2. Loosen the Ring Lock and align red with blue dots or Crosshatch at the center of the screen by rotating (RB) C.P. Magnets. (See Fig. 7.)
3. Align red / blue with green dots at the center of the screen by rotating (RB-G) C.P. Magnet. (See Fig. 8.)
4. Fix the C.P. Magnets by tightening the Ring Lock.
5. Remove the DY Wedges and slightly tilt the Deflection Yoke horizontally and vertically to obtain the best overall convergence.
6. Fix the Deflection Yoke by carefully inserting the DY Wedges between CRT and Deflection Yoke.

BLOCK DIAGRAMS

Servo/System Control Block Diagram

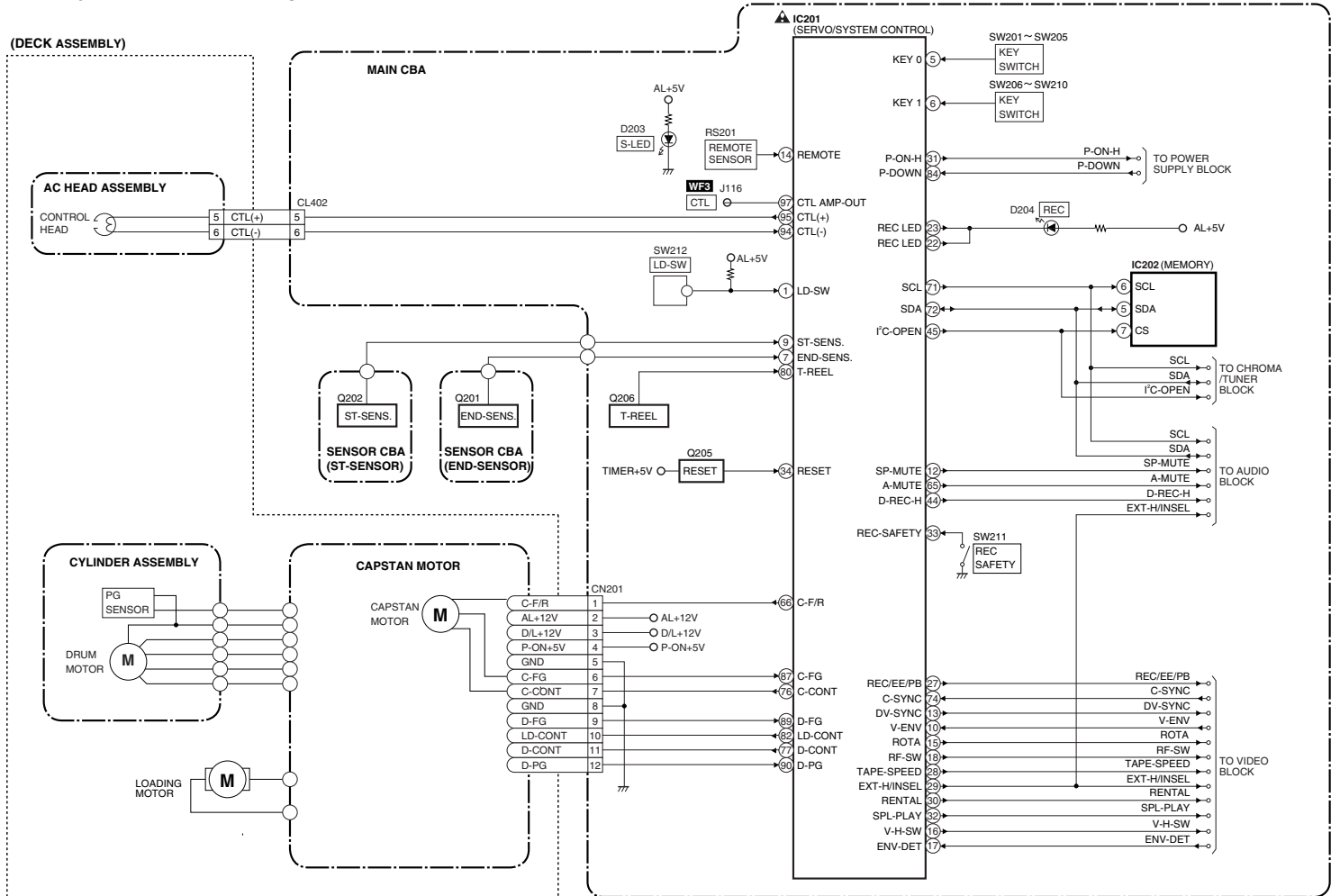

1-8-1

1-8-2

T5304BLS

Video Block Diagram

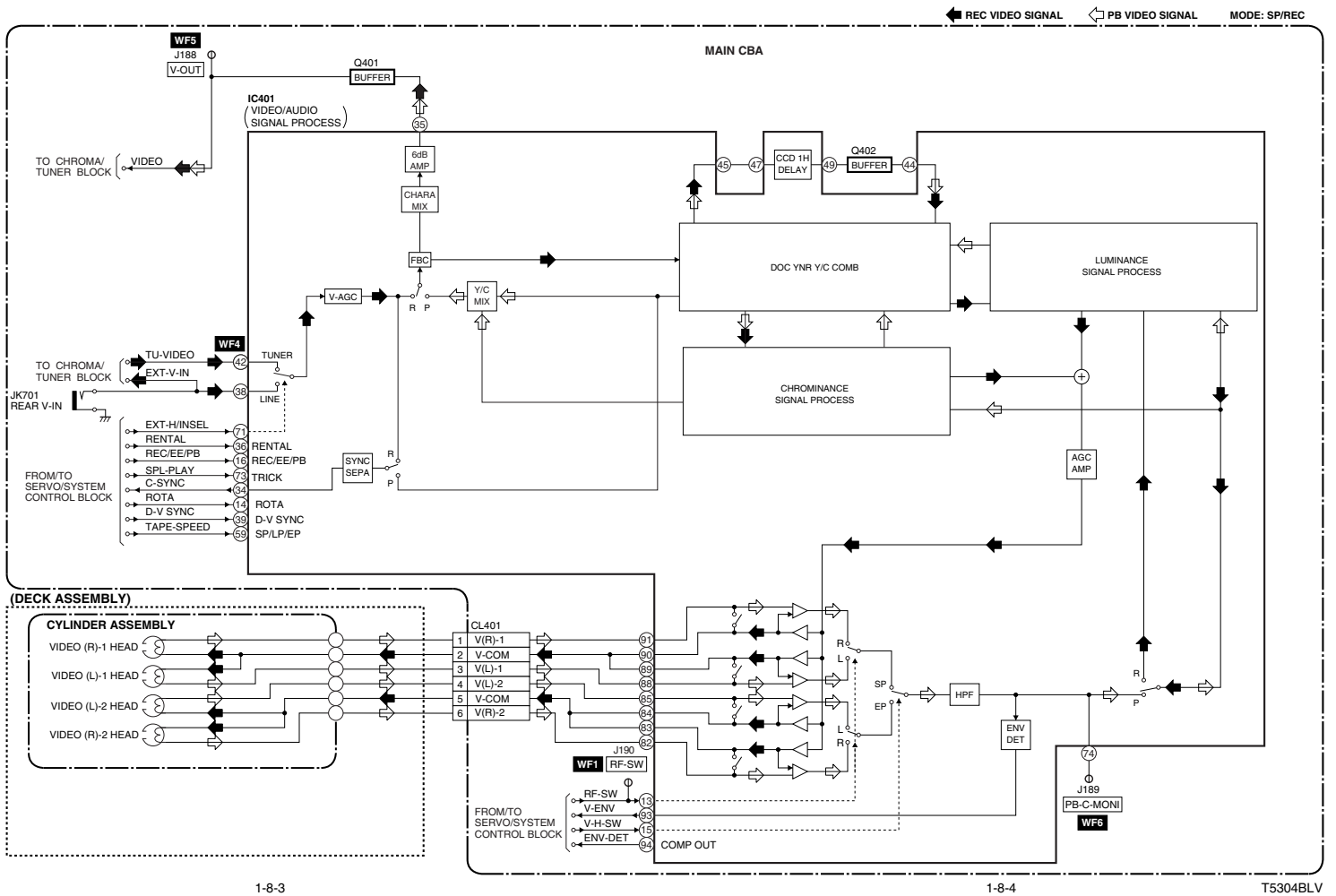

Audio Block Diagram

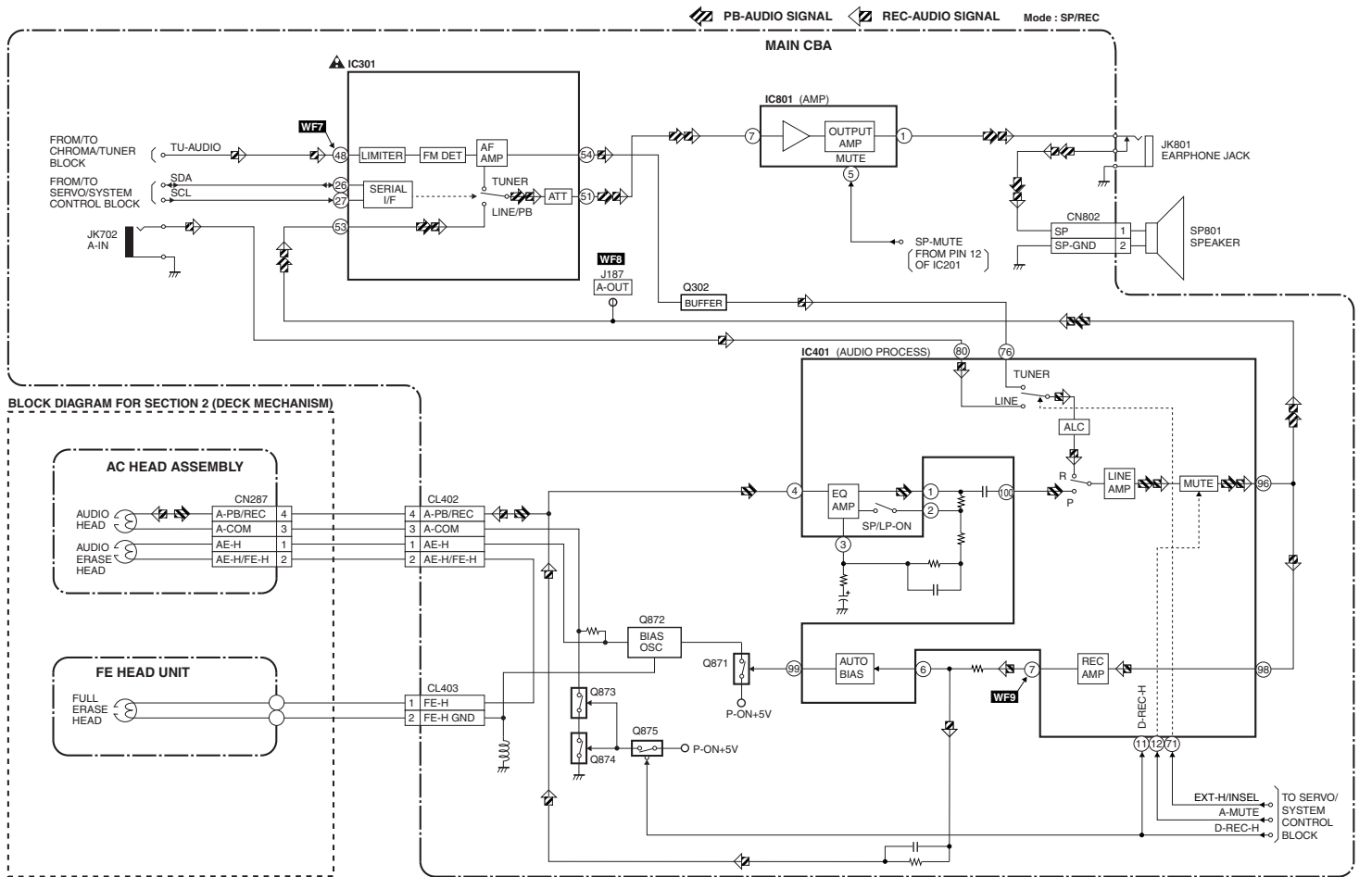

1-8-5

1-8-6

T5304BLA

Chroma/Tuner Block Diagram

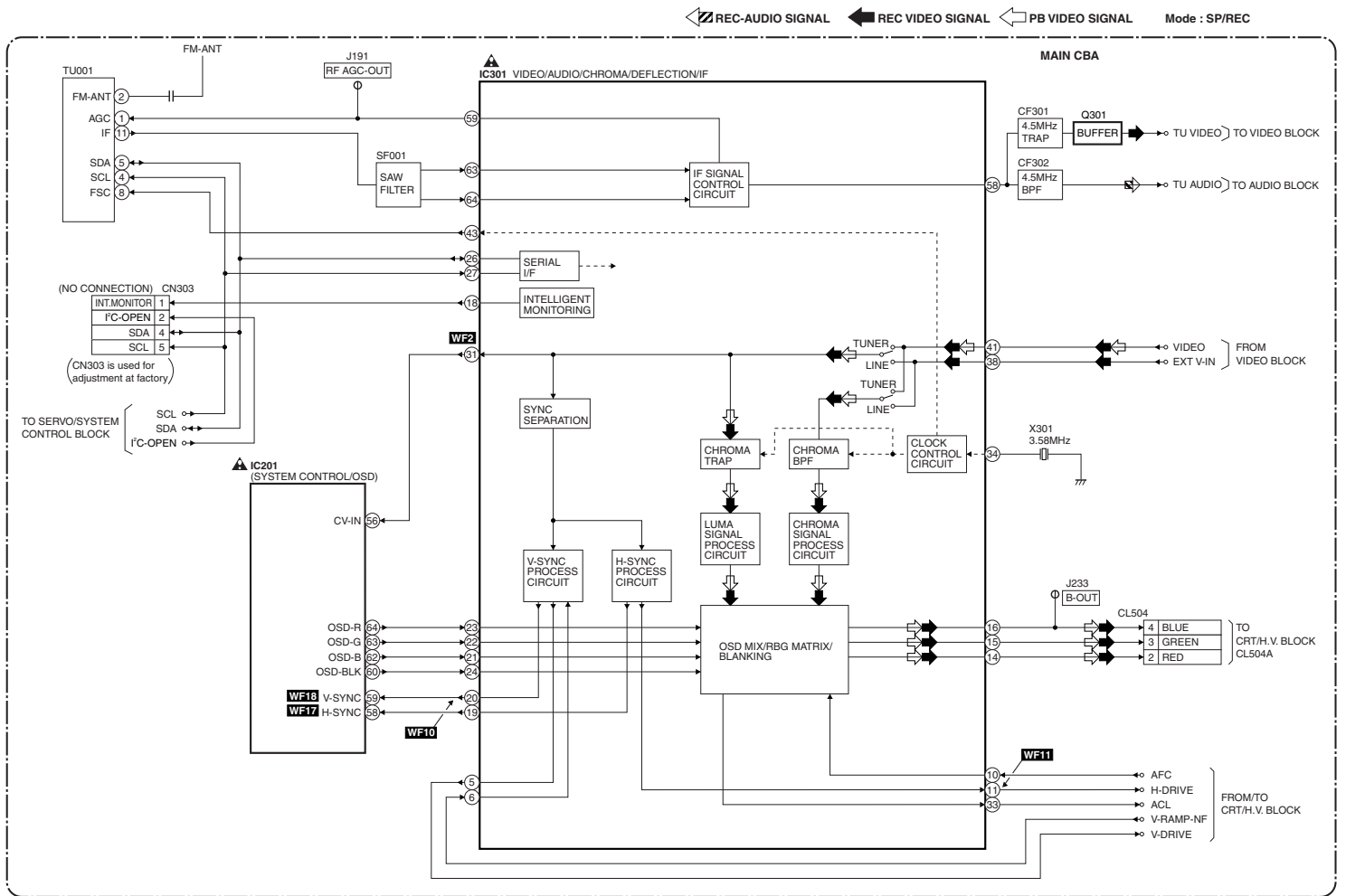

CRT/H.V. Block Diagram

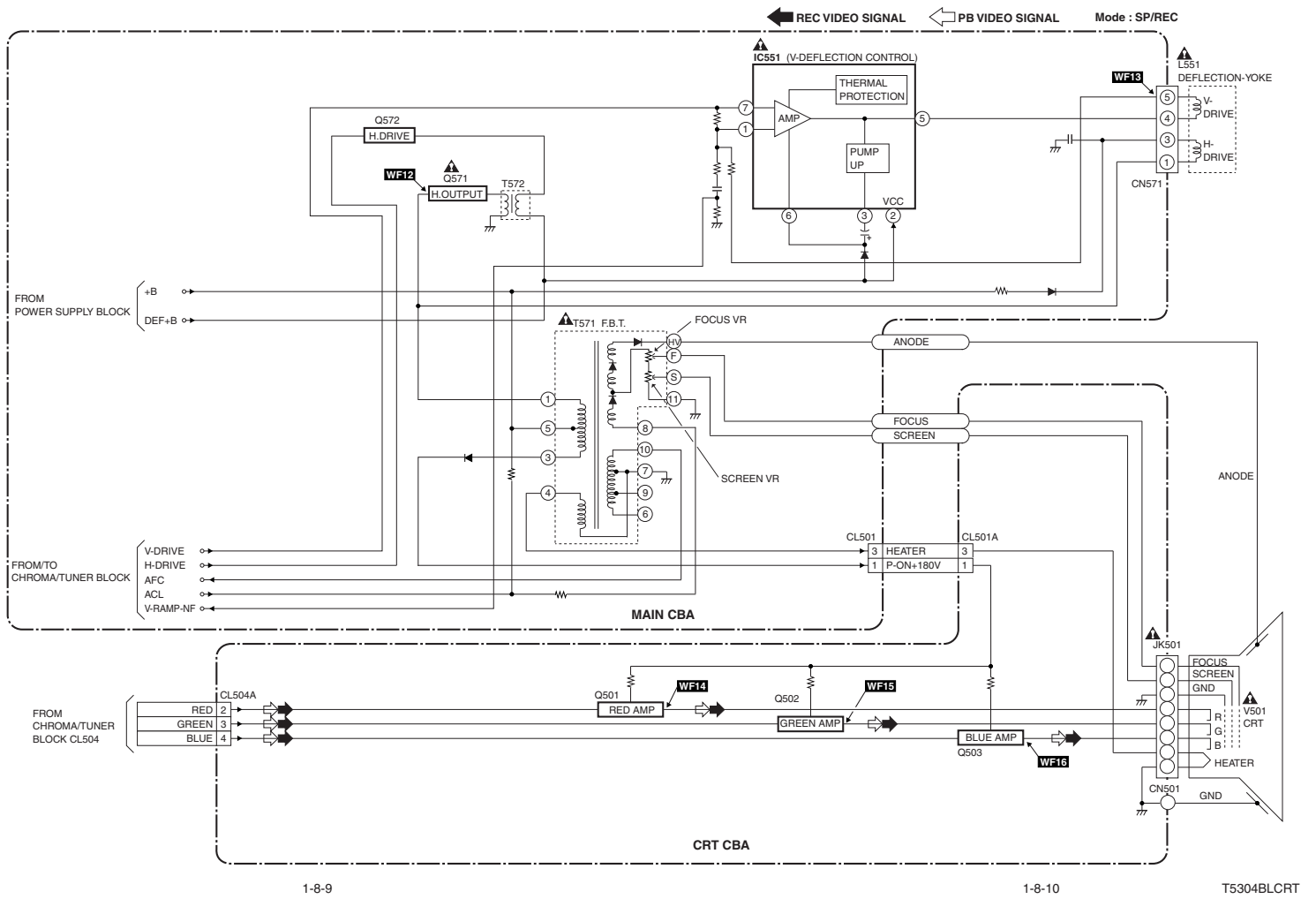

1-8-9

1-8-10

T5304BLCRT

Power Supply Block Diagram

CAUTION !
Switching power supply circuit is used in this unit.
If Main Fuse (F601) is blown, check to see that all components in the power supply circuit are not defective before you connect the AC plug to the AC power supply.
Otherwise it may cause some components in the power supply circuit to fail.



CAUTION
FOR CONTINUED PROTECTION AGAINST FIRE HAZARD,
REPLACE ONLY WITH THE SAME TYPE FUSE.
ATTENTION : POUR UNE PROTECTION CONTINUE LES RISQUES
D'INCELE N'UTILISER QUE DES FUSIBLE DE MEMO TYPE.
RISK OF FIRE-REPLACE FUSE AS MARKED.
This symbol means fast operating fuse.
Ce symbole représente un fusible à fusion rapide.

NOTE :
The voltage for parts in hot circuit is measured using
hot GND as a common terminal.

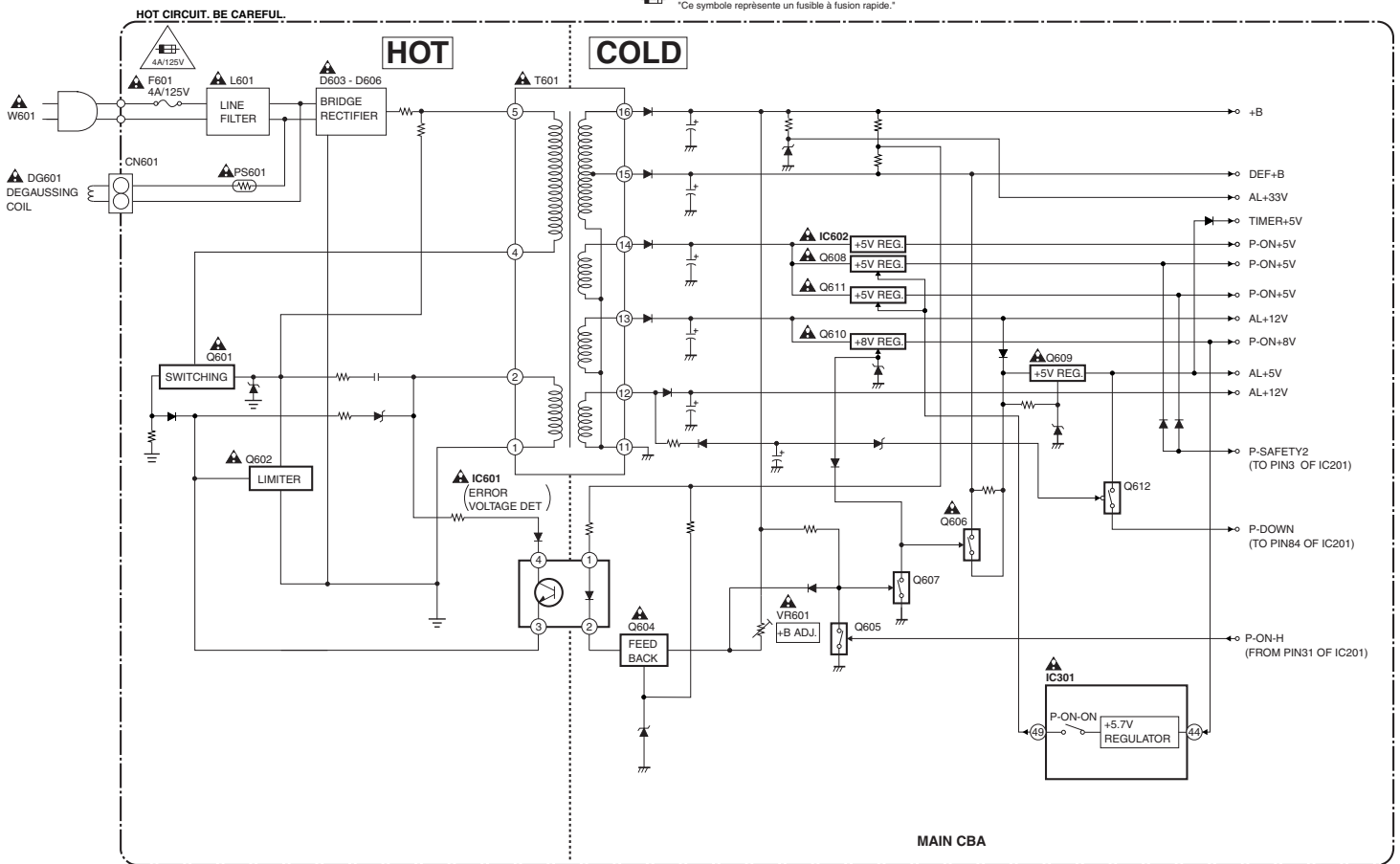

1-8-11

1-8-12

T5304BLP

MECHANICAL TROUBLE INDICATOR

1, Each Malfunction Indication

If the MONITOR is turned ON right after the Mechanical Malfunction occurs or POWER SAFETY/X-RAY is turned ON, display the following character to show Malfunction after the EJECT display.

Immediately preceding Malfunction	Display character
REEL Malfunction	R
DRUM Malfunction	D
CASSETTE LOADING Malfunction	C
TAPE LOADING Malfunction	T
P-SAFETY 1	1
P-SAFETY 2	2
P-SAFETY 3	3
X-RAY	X

Example: If REEL Malfunction

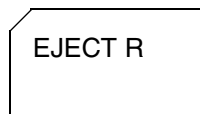

2, Each Malfunction evaluation method

X-RAY protect

If X-RAY port becomes continuously 2.5V or more for 120 msec. (4 times 40 msec. interval), the unit shall immediately turn OFF the POWER/MONITOR and switch over to the Mechanical Malfunction mode with POWER OFF.

(To return from this mode shall become possible only by POWER Key as in the case of the Mechanical Malfunction).

POWER SAFETY

1) POWER SAFETY 1

If P-SAFETY 1 port becomes continuously 2.5V or less for 120 msec. (4 times 40 msec. interval) when MONITOR is ON, the unit shall be assumed to be the Power Malfunction 1 and immediately turn OFF the POWER/MONITOR and switch over to the Mechanical Malfunction mode with POWER OFF.

(Shall not unload)

(To return from this mode shall become possible only by POWER Key as in the case of the Mechanical Malfunction).

* However the POWER SAFETY 1 function shall be disabled during 500 msec. right after the MONITOR turns ON.

2) POWER SAFETY 2

If P-SAFETY 2 port becomes continuously 2.5V or less for 120 msec. (4 times 40 msec. interval) when P-ON-H port is ON, the unit shall be assumed to be the Power Malfunction 2 and immediately turn OFF the POWER/MONITOR and switch over to the Mechanical Malfunction mode with POWER OFF.

(Shall not unload)

(To return from this mode shall become possible only by POWER Key as in the case of the Mechanical Malfunction).

* However the POWER SAFETY 2 function shall be disabled during 500 msec. right after the P-ON-H turns ON.

3) POWER SAFETY 3

If P-SAFETY 3 port becomes continuously 2.5V or over for 120 msec. (4 times 40 msec. interval) when MONITOR is ON, P-SAFETY 3 function is available. After that, if P-SAFETY 3 port becomes continuously 2.5V or less for 120 msec. (4 times 40 msec. interval), the unit shall be assumed to be the Power Malfunction 3 and immediately turn OFF the POWER/MONITOR and switch over to the Mechanical Malfunction mode with POWER OFF.

(Shall not unload)

(To return from this mode shall become possible only by POWER Key as in the case of the Mechanical Malfunction).

* However the POWER SAFETY 3 function shall be disabled during 500 msec. right after the MONITOR turns ON.

Mechanical Malfunction determination

1) REEL Malfunction detection

Countermeasure for REEL and CAPSTAN motor rotation malfunction (Except CASSETTE LOADING function)

After the Malfunction detection with REEL/CAPSTAN sensor, the unit shall switch over to STOP (B) and be REEL Mechanical Malfunction.

- a) If the T-REEL pulse is not impressed after a lapse of 5 sec. at SP, 10 sec. at LP, 14 sec. at SLP, or more in the REEL Rotation Mode like PLAY/REC, FS/RS Mode, and the T-REEL or S-REEL pulse is not impress after a lapse of 4 sec. or more in REEL Rotation Mode of FF/REW, it shall be assumed to stop the rotation and switch over to STOP (B) position, then POWER be turned OFF and the unit be REEL Mechanical Malfunction. (T-REEL and S-REEL for the models on S-REEL and only T-REEL for other models)
- b) If the C-FG pulse is not impressed for a lapse of 1 sec. or more during the CAPSTAN MOTOR rotation, it shall be MOTOR Rotation Malfunction (REEL Malfunction).

2) DRUM Malfunction detection

Detect the DRUM rotation at the D-FG input terminal.

If the variation of D-FG input level is not detected for a lapse of 1 sec. or more when D-CONT is "H", it shall be assumed to be Rotation Malfunction and be DRUM Malfunction.

When detect Drum Malfunction, POWER shall be turned OFF after the unit switches over to STEP (B) Mode.

3) Countermeasure for TAPE LOADING Malfunction

Detect the Malfunction with the LOADING Switch.

a) TAPE LOADING Malfunction

If LD-SW does not go to the established position after a lapse of 7 sec. or more from TAPE LOADING or TAPE UNLOADING start, the LOADING function shall immediately be stopped and POWER be turned OFF, and inform the Timer about the LOADING Mechanical Malfunction.

b) LD-SW Position Malfunction at each mode

When the unit operates at each mode, even if the LD-SW position changes from the established one in its mode, it keeps the function according to its mode.

4) Countermeasure for CASSETTE LOADING Malfunction

a) CASSETTE IN operating Malfunction

If LD-SW does not go to SB position after a lapse of 5 sec. or more from the CASSETTE insertion start, the unit starts the CASSETTE OUT operation.

After switch over to CASSETTE OUT operation and then a laps of 5 sec. or more from the CASSETTE OUT operation start, if LD-SW does not go to the EJ position or if START Sensor and END Sensor does not turn "ON" at the EJ position, the unit starts again to insert CASSETTE.

(However in S-INH state, the START/END Sensor shall be disabled).

b) CASSETTE OUT operating Malfunction

After a lapse of 5 sec. or more from CASSETTE OUT operation start, if LD-SW does not go to the EJ position or if START Sensor and END Sensor does not turn "ON" at the EJ position, the unit starts to insert CASSETTE.

(However in S-INH state, the START/END Sensor shall be disabled).



When the unit switches over to CASSETTE insertion at CASSETTE IN or CASSETTE OUT Malfunction, if LD-SW does not go to the SB position after a lapse of 5 sec. or more from CASSETTE insertion start, the function shall immediately be stopped and POWER be turned OFF, and the unit be CASSETTE LOADING Malfunction.

c) When POWER is turned ON, if the CL position or GC position cannot be detected after 5 sec. LD-REV operation and 5 sec. LD-FWD operation, the function shall immediately be stopped and POWER be turned OFF, and the unit be CASSETTE LOADING Malfunction.

d) When POWER is turned ON without CASSETTE (EJ position) and LD-SW is monitored all the time, if the CL or GC position is detected continuously for 1 sec. or more, the POWER shall be turned OFF and the unit be CASSETTE LOADING Malfunction.

Countermeasure for Mechanical Malfunction

If the unit detects Mechanical Malfunction, turn the POWER OFF. If the unit is Mechanical Malfunction, Key input except POWER key shall be disabled and CASSETTE insertion disabled. When POWER Key is entered, the POWER is turned ON and the unit switches over the EJECT Mode. (Return with POWER ON)

Power Supply Trouble Shooting Guide

It is highly recommended that a variable isolation transformer which can monitor current be used. (Alternatively a variable AC source which monitors current will do). Read directions below before power is added!

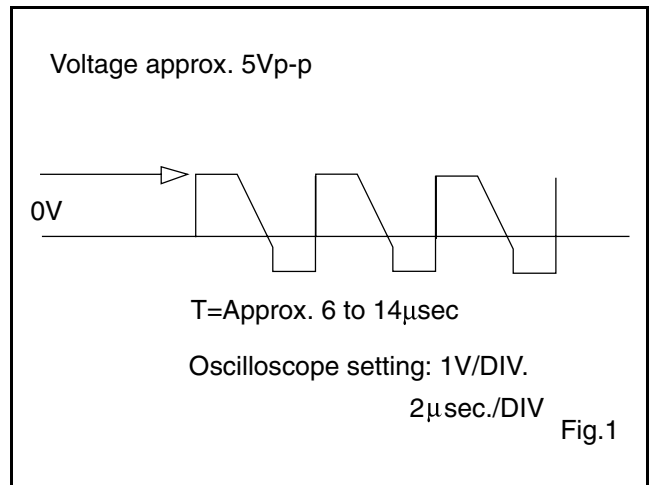
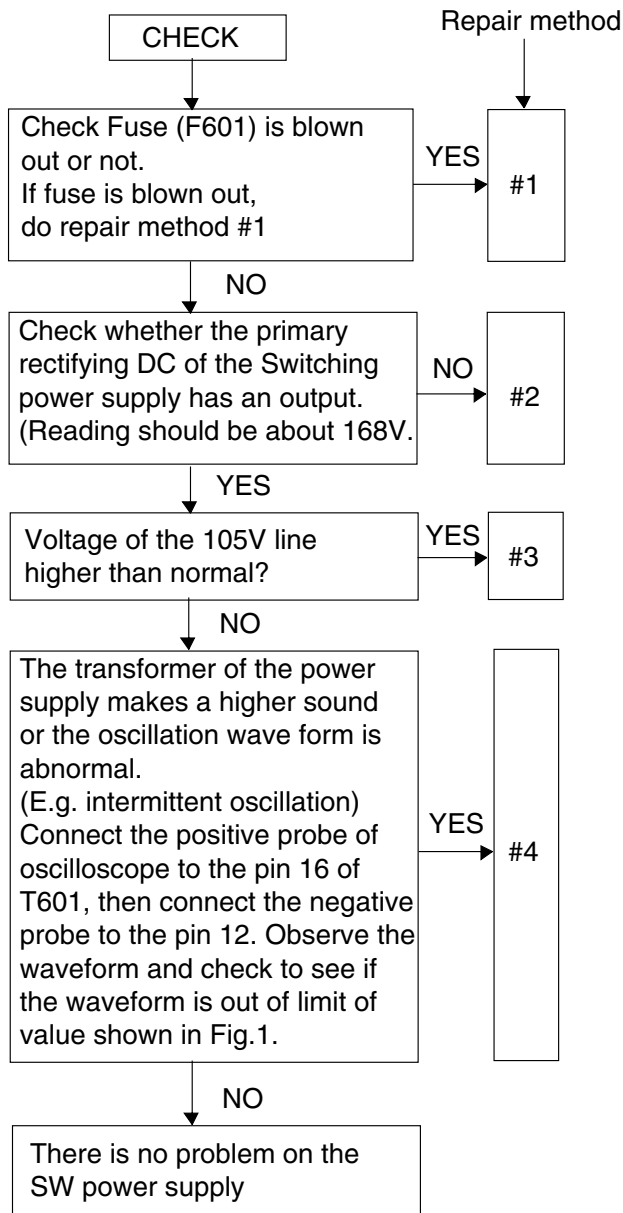

Repair method #1

(Power must be off)

Short circuit in the secondary side. check diode D613, D614, D616, D617 and D618, switching transistor (Q601), control transistor (Q602), diode and resistor replace as necessary.

Disconnect 105V diode (D613), 25V diode (D614), 8V diode (D616), 12V diode (D617), 12V diode (D618) and Check the load continuity of 105V line, 25V line, 8V line, 12V line through a tester (resistance range).

If the tester indicates a lower resistance value around 0 ohm, the line is short-circuited.

Before repairing the switching power supply, find out the short-circuited area of such line and repair it.

If the tester does not indicate any low resistance value (around 0 ohm), no load is short-circuited and there is no problem.

Check for any defective parts while the secondary rectifying diodes are disconnected (D613, D614, D616, D617 and D618) perform a diode check in both forward and reverse directions through a tester.

Repair method #2

Check the primary rectifying diodes (D603-D606) as possible problems. Remove the above mentioned parts and check them. Perform check according to the step 1 and 2 of repair method #1 and check for defects following parts, then if necessary replace with factory originals.

R602 is open or not.

Q601, Q602, D607, D608 and D611 are short or not.

Repair method #3

The feedback circuit which is monitored by the output of D613 105V may not work and this may be regarded as a possible cause, remove IC601 (Photo Coupler), diode (D620) and transistor (Q604) check for defects.

Repair method #4

Check control circuitry which is connecting to Pin 2 and 1 of Switching Transformer T601.

SCHEMATIC DIAGRAMS / CBA'S AND TEST POINTS

Standard Notes

Warning

Many electrical and mechanical parts in this chassis have special characteristics. These characteristics often pass unnoticed and the protection afforded by them cannot necessarily be obtained by using replacement components rated for higher voltage, wattage, etc. Replacement parts that have these special safety characteristics are identified in this manual and its supplements; electrical components having such features are identified by the mark "▲" in the schematic diagram and the parts list. Before replacing any of these components, read the parts list in this manual carefully. The use of substitute replacement parts that do not have the same safety characteristics as specified in the parts list may create shock, fire, or other hazards.

Note:

1. Do not use the part number shown on these drawings for ordering. The correct part number is shown in the parts list, and may be slightly different or amended since these drawings were prepared.
2. All resistance values are indicated in ohms ($K=10^3$, $M=10^6$).
3. Resistor wattages are 1/4W or 1/6W unless otherwise specified.
4. All capacitance values are indicated in μF ($P=10^{-6}\mu F$).
5. All voltages are DC voltages unless otherwise specified.

Capacitor Temperature Markings

Mark	Capacity change rate	Standard temperature	Temperature range
(B)	$\pm 10\%$	20°C	-25~+85°C
(F)	+30 -80%	20°C	-25~+85°C
(SR)	$\pm 15\%$	20°C	-25~+85°C
(Z)	+30 -80%	20°C	-10~+70°C

Capacitors and transistors are represented by the following symbols.

CBA Symbols

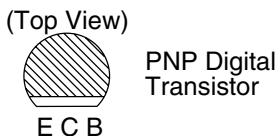
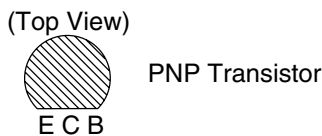
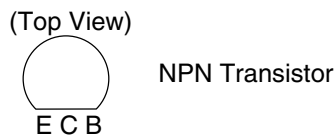
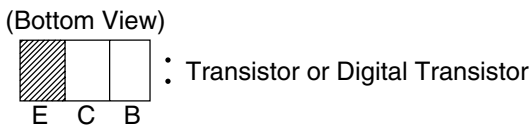
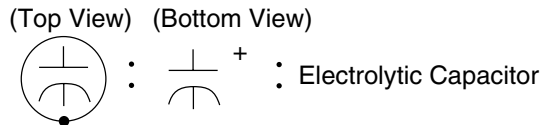

Schematic Diagram Symbols

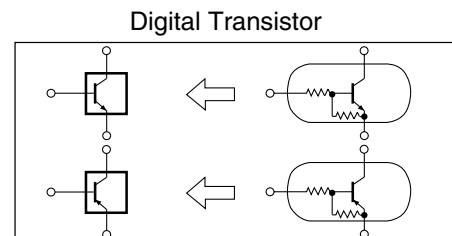

LIST OF CAUTION, NOTES, AND SYMBOLS USED IN THE SCHEMATIC DIAGRAMS ON THE FOLLOWING PAGES:

1. CAUTION:

FOR CONTINUED PROTECTION AGAINST FIRE HAZARD, REPLACE ONLY WITH THE SAME TYPE FUSE.

2. CAUTION:

Fixed Voltage (or Auto voltage selectable) power supply circuit is used in this unit.

If Main Fuse (F601) is blown, first check to see that all components in the power supply circuit are not defective before you connect the AC plug to the AC power supply. Otherwise it may cause some components in the power supply circuit to fail.

3. Note:

- (1) Do not use the part number shown on the drawings for ordering. The correct part number is shown in the parts list, and may be slightly different or amended since the drawings were prepared.
- (2) To maintain original function and reliability of repaired units, use only original replacement parts which are listed with their part numbers in the parts list section of the service manual.

4. Wire Connectors

- (1) Prefix symbol "CN" means "connector" (can disconnect and reconnect).
- (2) Prefix symbol "CL" means "wire-solder holes of the PCB" (wire is soldered directly).

5. Note: Mark "•" is a leadless (chip) component.

6. Mode: SP/REC

7. Voltage indications for PLAY and REC modes on the schematics are as shown below:

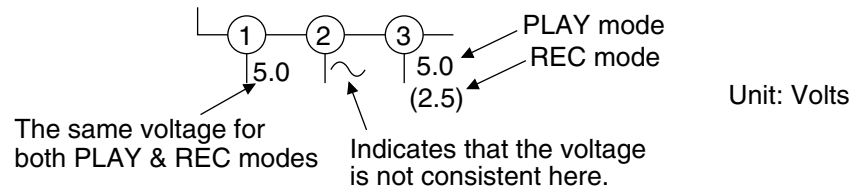

8. How to read converged lines

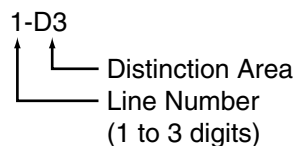

Examples:

1. "1-D3" means that line number "1" goes to area "D3".
2. "1-B1" means that line number "1" goes to area "B1".

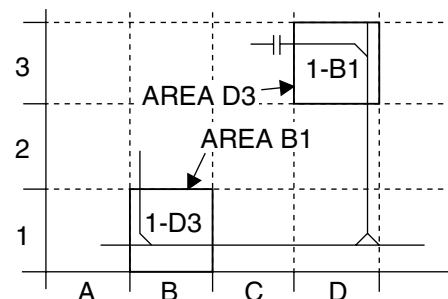

9. Test Point Information

- ⊙ : Indicates a test point with a jumper wire across a hole in the PCB.
- : Used to indicate a test point with a component lead on foil side.
- ⊘ : Used to indicate a test point with no test pin.
- : Used to indicate a test point with a test pin.

Main 1/4 Schematic Diagram

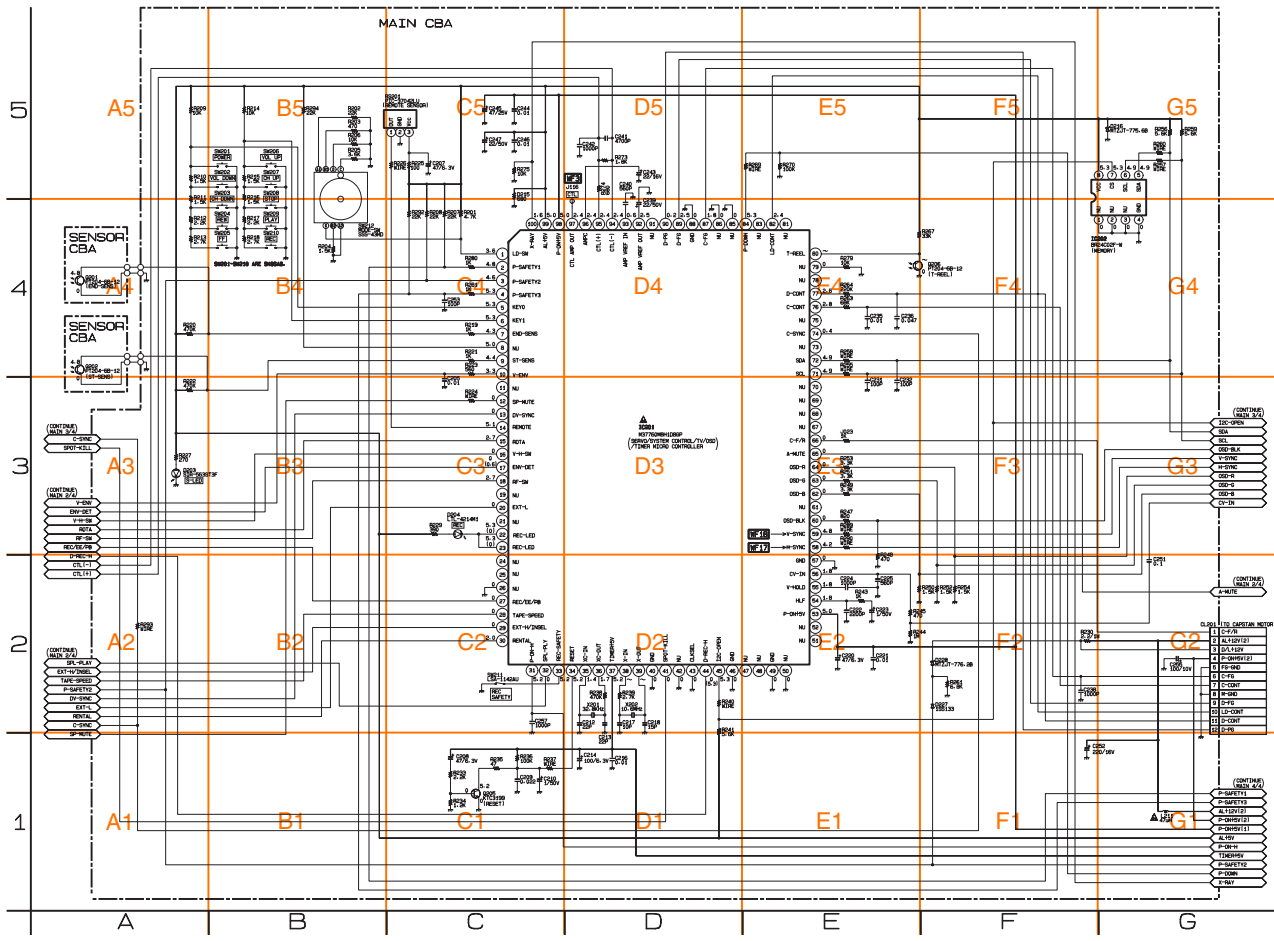

MAIN 1/4		
Ref No.	Position	
ICS		
IC201	D-3	
IC202	F-4	
TRANSISTORS		
Q205	C-1	
Q206	F-4	
TEST POINTS		
J115	D-5	
CONNECTORS		
CL201	G-2	

Main 2/4 Schematic Diagram

— REC Video Signal
◀ REC Audio Signal
— PB Video Signal
◀ PB Audio Signal

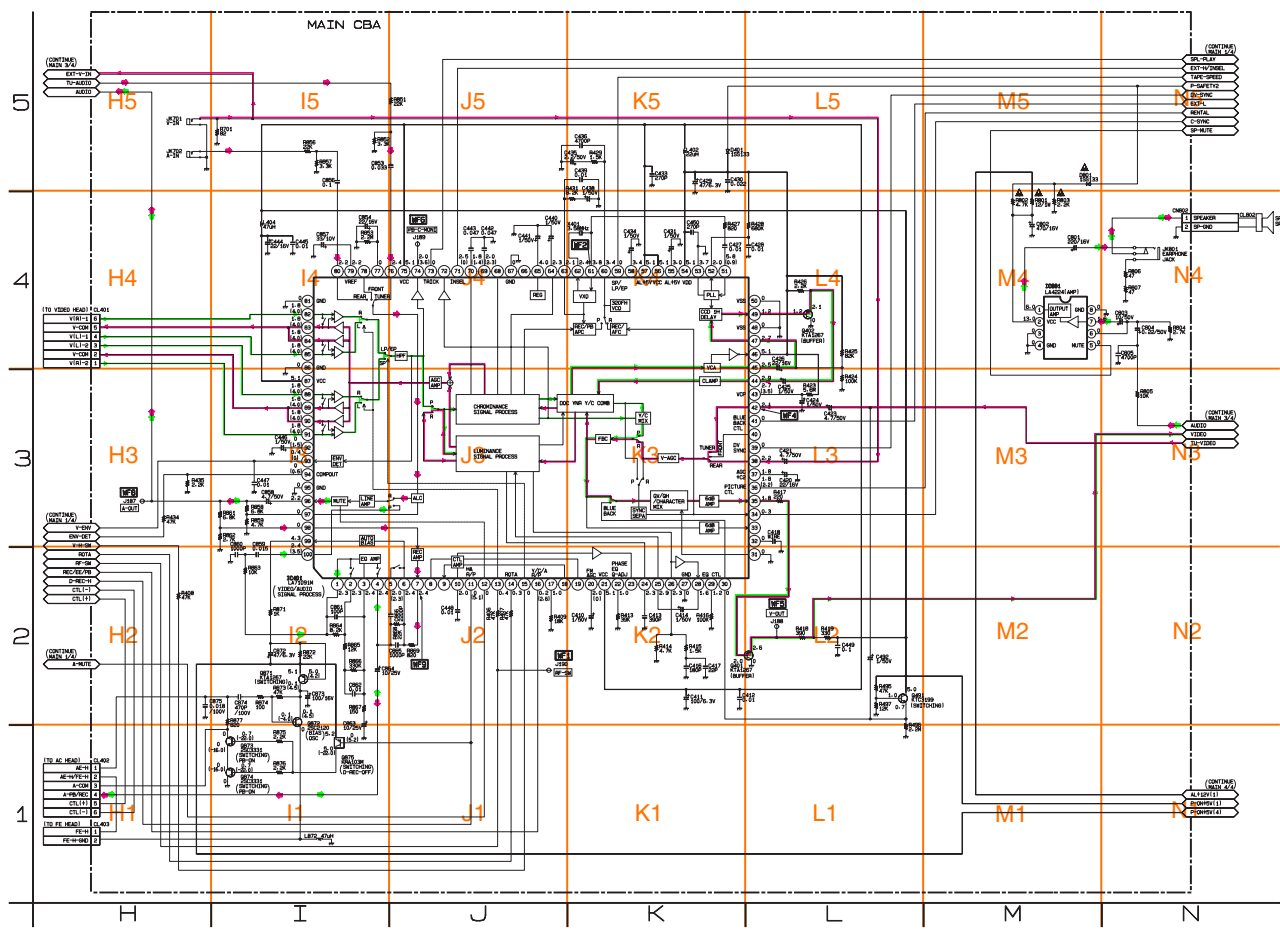

Ref No.	Position
MAIN 2/4	
ICS	
IC401	I-2
IC301	M-4
TRANSISTORS	
Q401	K-2
Q402	L-4
Q491	L-2
Q871	I-2
Q872	I-2
Q873	I-1
Q874	I-1
Q875	I-1
TEST POINTS	
J187	H-3
J188	L-2
J189	J-4
J190	J-2
CONNECTORS	
CL401	H-4
CL402	H-1
CL403	H-1
CN802	N-4

1-9-6

1-9-7

1-9-8

T5304SCM2

Main 3/4 Schematic Diagram

— REC Video Signal
◀ REC Audio Signal
— PB Video Signal
◀ PB Audio Signal

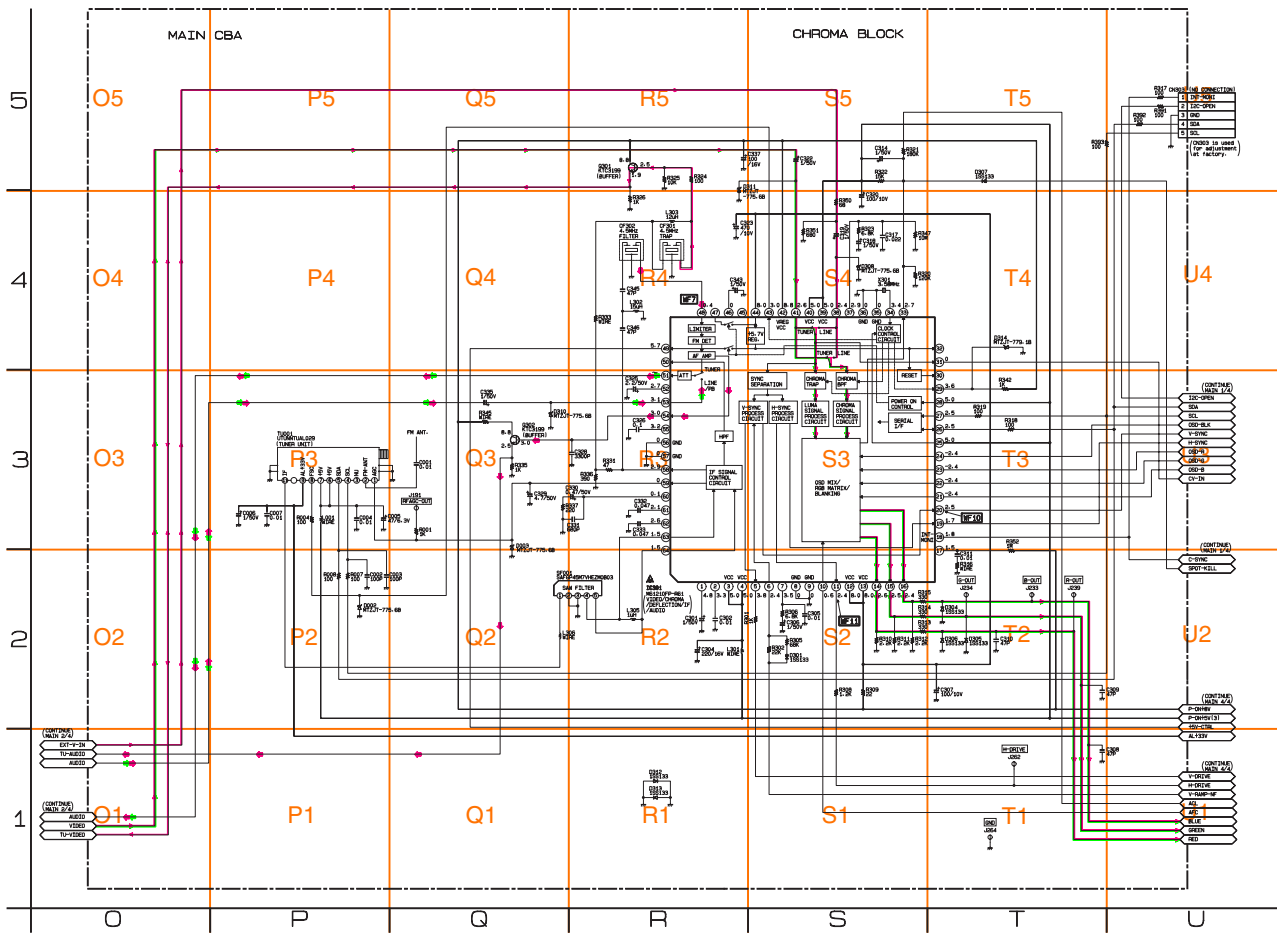

Ref No.	Position
IC301	ICS
Q301	R-2
Q302	R-5
Q302	Q-3
J191	Q-3
J233	T-2
J234	T-2
J239	T-2
J262	T-1
J264	T-1
CONNECTORS	
CN303	U-5

Main 4/4 Schematic Diagram

NOTE:
THE VOLTAGE FOR PARTS IN HOT CIRCUIT IS MEASURED USING
HOT GND AS A COMMON TERMINAL.

CAUTION !
Fixed voltage power supply circuit is used in this unit.
If Main Fuse (F601) is blown, check to see that all components in the power supply
circuit are not defective before you connect the AC plug to the AC power supply.
Otherwise it may cause some components in the power supply circuit to fail.



CAUTION
FOR CONTINUED PROTECTION AGAINST FIRE HAZARD,
REPLACE ONLY WITH THE SAME TYPE FUSE.
ATTENTION : POUR UNE PROTECTION CONTINUE LES RISQUES
D'INCENDIE N'UTILISER QUE DES FUSIBLES DE MEME TYPE.
RISK OF FIRE-REPLACE FUSE AS MARKED.
Ce symbole signifie fusible à fusion rapide.

REC Video Signal

PB Video Signal

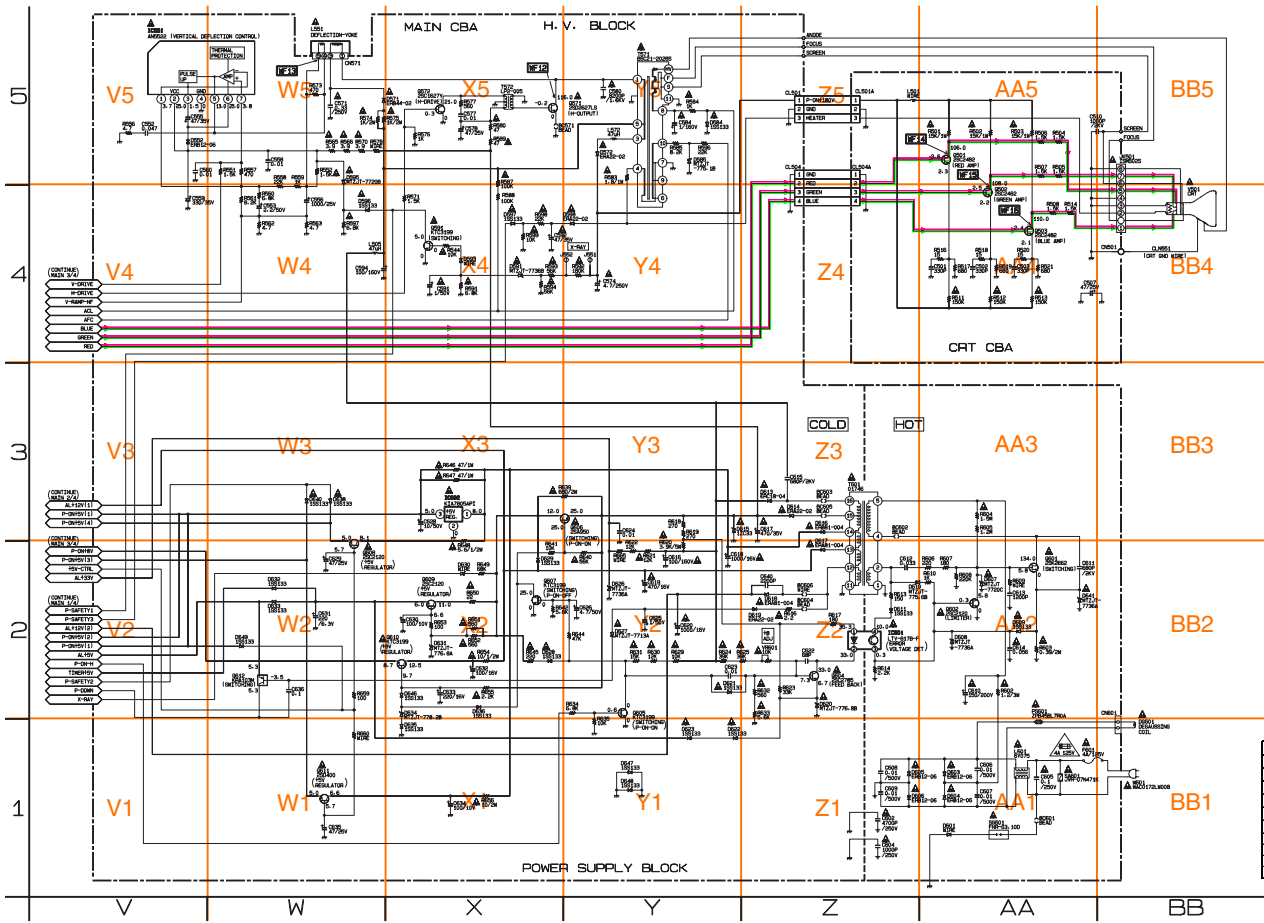

CRT

Ref No.	Position
TRANSISTORS	
Q601	AA-5
Q602	AA-4
Q603	AA-4
CONNECTORS	
CL501A	Z-5
CL504A	Z-5
CN501	BB-4

MAIN 4/4

Ref No.	Position
ICS	
ICS51	V-5
IC601	Z-2
IC602	X-3
TRANSISTORS	
Q671	Y-5
Q672	X-5
Q691	X-4
Q601	AA-2
Q602	AA-2
Q604	Z-2
Q605	Y-2
Q606	Y-3
Q607	X-2
Q608	W-2
Q609	X-2
Q610	X-2
Q611	W-1
Q612	W-2
TEST POINTS	
J551	Y-4
J552	Y-4
CONNECTORS	
CL501	Z-5
CL504	Z-5
CN571	W-5
CN601	BB-2
ADJUSTMENT	
VR601	Z-2

VOLTAGE CHART (Power off mode)

Ref. No.	S	D	G
Q601	0.0	137.0	1.8
Ref. No.	E	C	B
Q602	0	3.2	0.5
Q605	0	7.0	0
Q606	7.0	7.0	7.0
Q608	5.0	7.5	5.7
Q609	6.0	6.5	6.6
Q610	0.7	4.7	1.3
Q611	0	2.4	0
Q612	5.3	5.3	0.8

Main CBA Top View

CAUTION!
Fixed voltage power supply circuit is used in this unit.
If Main Fuse (F501) is blown, check to see that all components in the power supply circuit are not defective before you connect the AC plug to the AC power supply.
Otherwise it may cause some components in the power supply circuit to fail.

CAUTION
FOR CONTINUED PROTECTION AGAINST FIRE HAZARD,
REPLACE ONLY WITH THE SAME TYPE FUSE.
ATTENTION : POUR UNE PROTECTION CONTINUE LES RISQUES
D'INCENDIE UTILISER QUE DES FUSIBLES DE MEME TYPE.
RISK OF FIRE-REPLACE FUSE AS MARKED.
*This symbol means fast operating fuse.
*Ce symbole représente un fusible à fusion rapide.



Sensor CBA Top View (END-SENSOR)

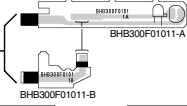

BECAUSE A HOT CHASSIS GROUND IS PRESENT IN THE POWER SUPPLY CIRCUIT, AN ISOLATION TRANSFORMER MUST BE USED. ALSO, IN ORDER TO HAVE THE ABILITY TO INCREASE THE INPUT SLOWLY, WHEN TROUBLESHOOTING THIS TYPE POWER SUPPLY CIRCUIT, A VARIABLE ISOLATION TRANSFORMER IS REQUIRED.

Sensor CBA Top View (START-SENSOR)

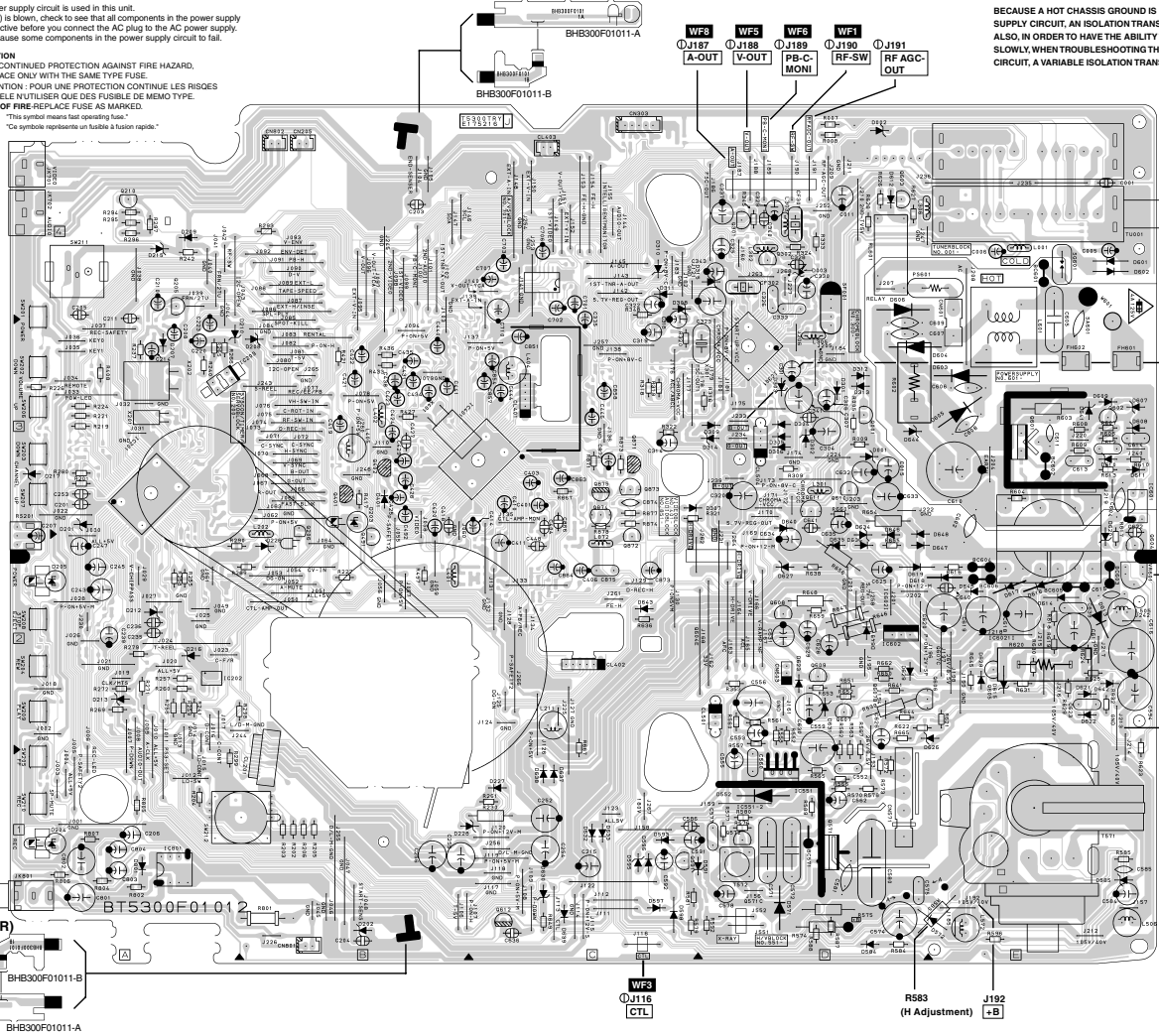
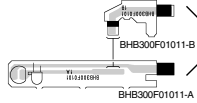

Ref No.	ICS	Position
IC201	A-3	
IC202	A-2	
IC301	D-3	
IC401	C-3	
IC551	D-1	
IC601	E-3	
IC602	D-2	
IC801	A-1	
TRANSISTORS		
Q205	A-4	
Q206	B-3	
Q301	D-4	
Q302	D-4	
Q401	B-3	
Q402	B-3	
Q491	B-3	
Q571	D-1	
Q572	D-1	
Q591	C-1	
Q601	E-3	
Q602	E-3	
Q604	E-2	
Q605	E-2	
Q606	E-2	
Q607	D-2	
Q608	D-2	
Q609	D-2	
Q610	D-3	
Q611	D-3	
Q612	C-1	
Q871	C-3	
Q872	C-2	
Q873	C-3	
Q874	C-3	
Q875	C-3	
TEST POINTS		
J116	C-1	
J187	D-4	
J188	D-4	
J189	D-4	
J190	D-4	
J191	D-4	
J233	D-3	
J234	D-3	
J239	D-3	
J262	D-3	
J264	D-3	
J551	D-1	
J552	D-1	
CONNECTORS		
CL201	B-1	
CL401	C-3	
CL402	C-2	
CL501	D-2	
CL504	D-3	
CLN303	C-4	
CLN74	D-1	

Main CBA Bottom View

CAUTION 1

Fixed voltage power supply circuit is used in this unit.
If Main Fuse (F601) is blown, check to see that all components in the power supply circuit are not defective before you connect the AC plug to the AC power supply. Otherwise it may cause some components in the power supply circuit to fail.



CAUTION
FOR CONTINUED PROTECTION AGAINST FIRE HAZARD,
REPLACE ONLY WITH THE SAME TYPE FUSE.
ATTENTION - POUR UNE PROTECTION CONTINUE LES RISQUES
D'INCENDIE UTILISER QUE DES FUSIBLES DE MEME TYPE.
RISK OF FIRE: REPLACE FUSE AS MARKED.

*This symbol means fast operating fuse.
Ce symbole représente un fusible à fusion rapide.

BECAUSE A HOT CHASSIS GROUND IS PRESENT IN THE POWER
SUPPLY CIRCUIT, AN ISOLATION TRANSFORMER MUST BE USED.
ALSO, IN ORDER TO HAVE THE ABILITY TO INCREASE THE INPUT
SLOWLY, WHEN TROUBLESHOOTING THIS TYPE POWER SUPPLY
CIRCUIT, A VARIABLE ISOLATION TRANSFORMER IS REQUIRED.

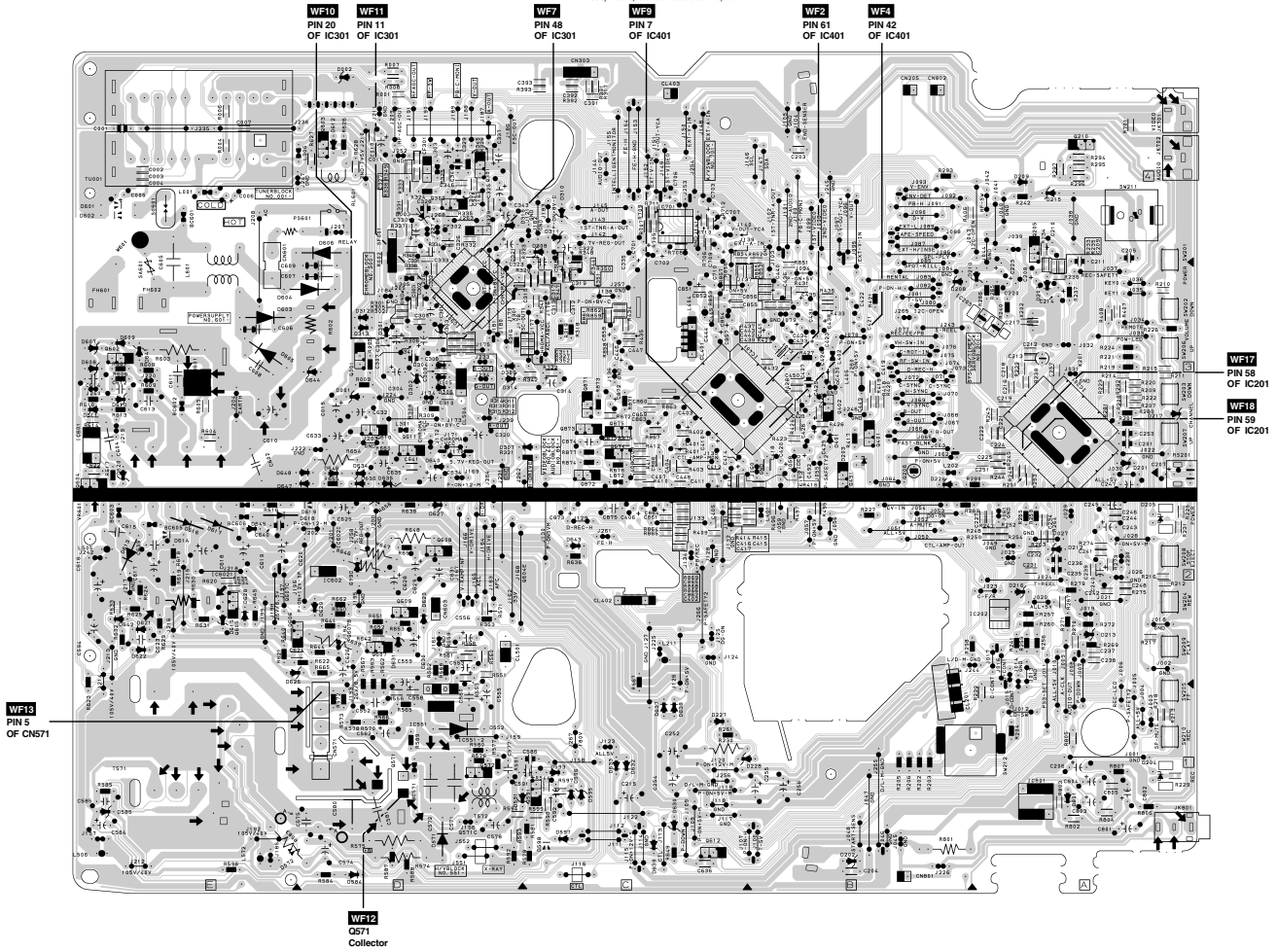

CRT CBA Top View

CRT CBA Bottom View

CRT CBA	
Ref No.	Position
TRANSISTORS	
Q501	B-2
Q502	B-2
Q503	B-2
CONNECTORS	
CL501A	B-2
CL504A	B-2
CN501	A-1

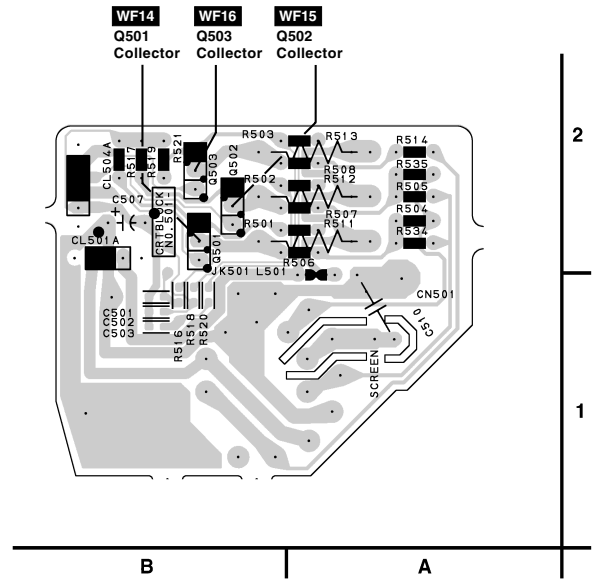
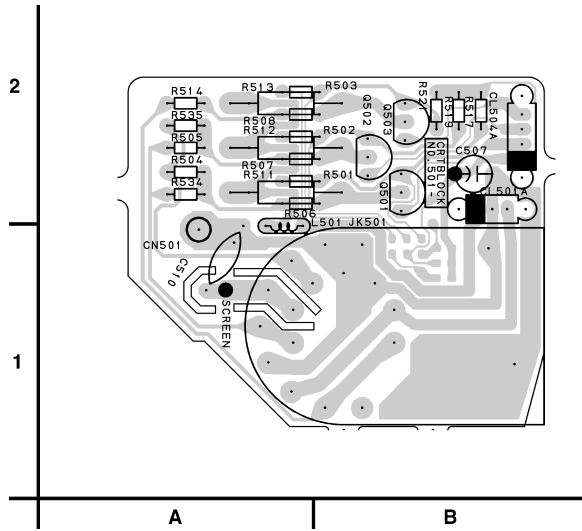

WAVEFORMS

WAVEFORM NOTES

INPUT: NTSC COLOR BAR SIGNAL
 OTHER CONTROLS: CENTER POSITION
 VOLTAGES SHOWN ARE RANGE OF
 OSCILLOSCOPE SETTING

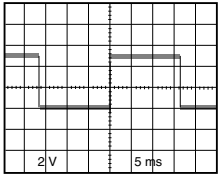

WF1 MAIN 2/4 SCHEMATIC DIAGRAM
 J190 RF-SW

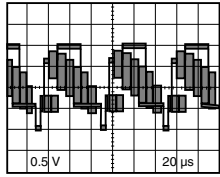

WF5 MAIN 2/4 SCHEMATIC DIAGRAM
 J188 V-OUT

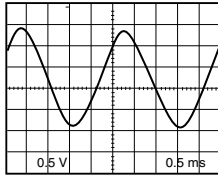

WF9 MAIN 2/4 SCHEMATIC DIAGRAM
 IC401 PIN 7

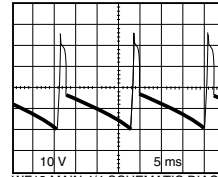

WF13 MAIN 4/4 SCHEMATIC DIAGRAM
 CN571 PIN 5

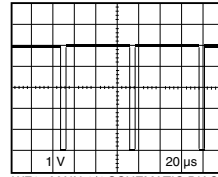

WF17 MAIN 1/4 SCHEMATIC DIAGRAM
 IC201 PIN 58

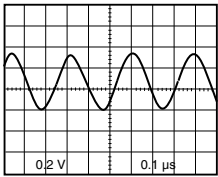

WF2 MAIN 2/4 SCHEMATIC DIAGRAM
 IC401 PIN 61

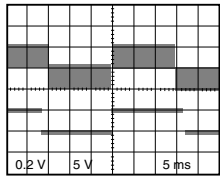

Upper: WF6 Lower: WF1
 MAIN 2/4 SCHEMATIC DIAGRAM
 J189 PB-C-MONI

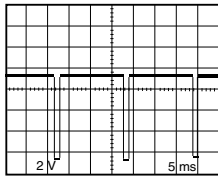

WF10 MAIN 3/4 SCHEMATIC DIAGRAM
 IC301 PIN 20

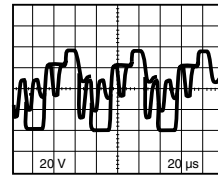

WF14 CRT SCHEMATIC DIAGRAM
 Q501 COLLECTOR

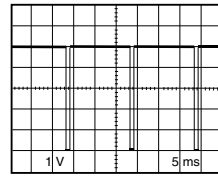

WF18 MAIN 1/4 SCHEMATIC DIAGRAM
 IC201 PIN 59

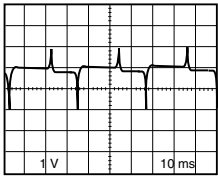

WF3 MAIN 1/4 SCHEMATIC DIAGRAM
 J116 CTL

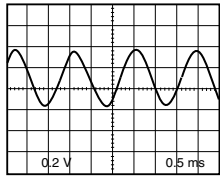

WF7 MAIN 3/4 SCHEMATIC DIAGRAM
 IC301 PIN 48

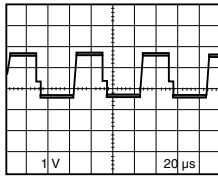

WF11 MAIN 3/4 SCHEMATIC DIAGRAM
 IC301 PIN 11

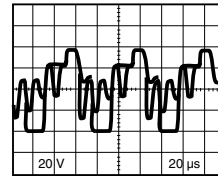

WF15 CRT SCHEMATIC DIAGRAM
 Q502 COLLECTOR

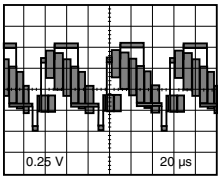

WF4 MAIN 2/4 SCHEMATIC DIAGRAM
 IC401 PIN 42

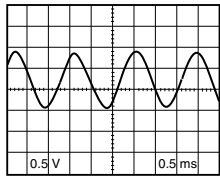

WF8 MAIN 2/4 SCHEMATIC DIAGRAM
 J187 A-OUT

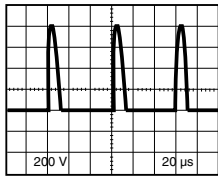

WF12 MAIN 4/4 SCHEMATIC DIAGRAM
 Q571 COLLECTOR

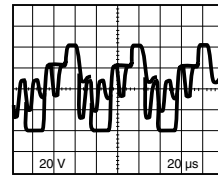

WF16 CRT SCHEMATIC DIAGRAM
 Q503 COLLECTOR

1-10-1

1-10-2

Z11WF

WIRING DIAGRAM

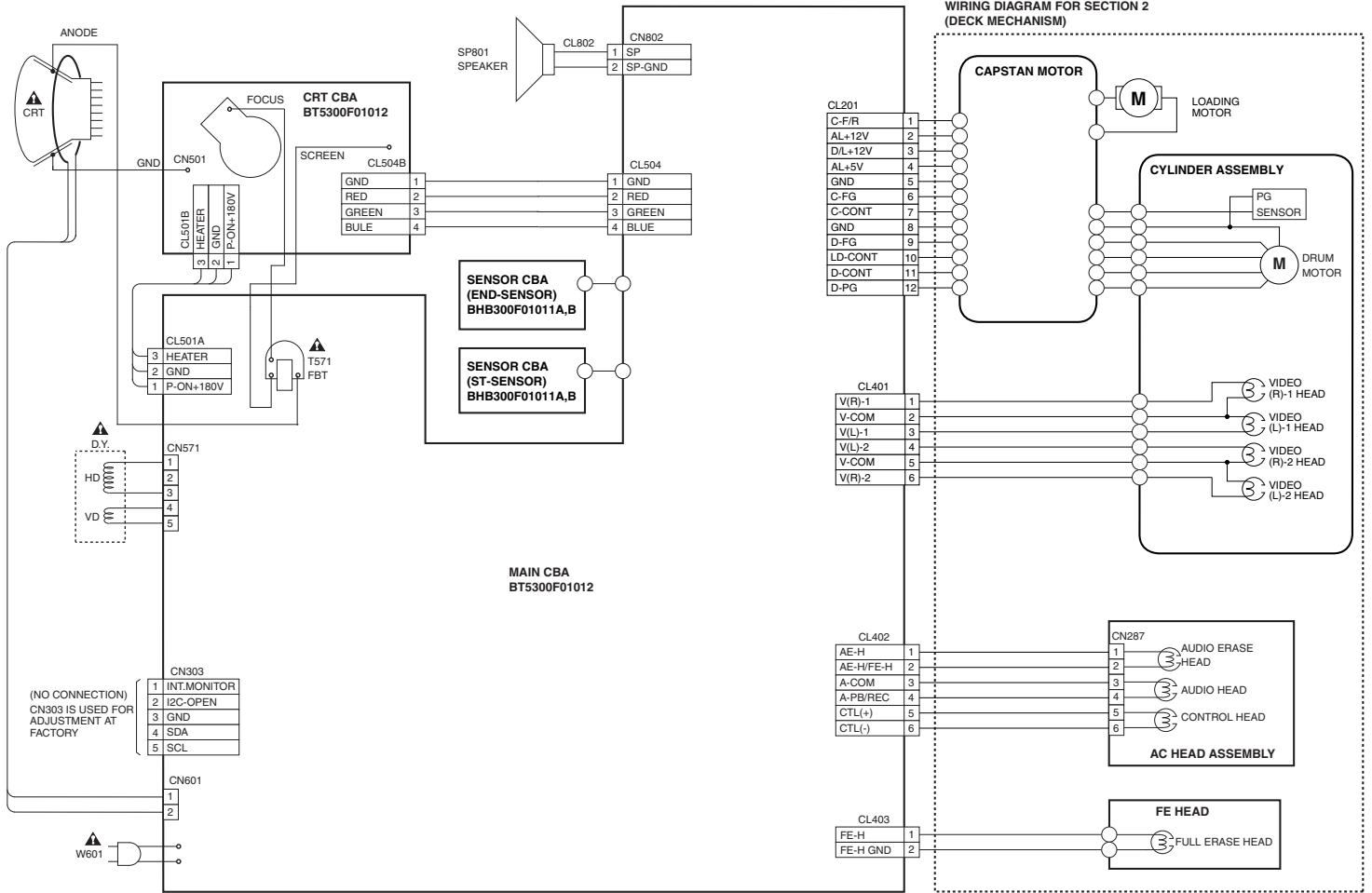

SYSTEM CONTROL TIMING CHARTS

Chart 1

1) SP MODE

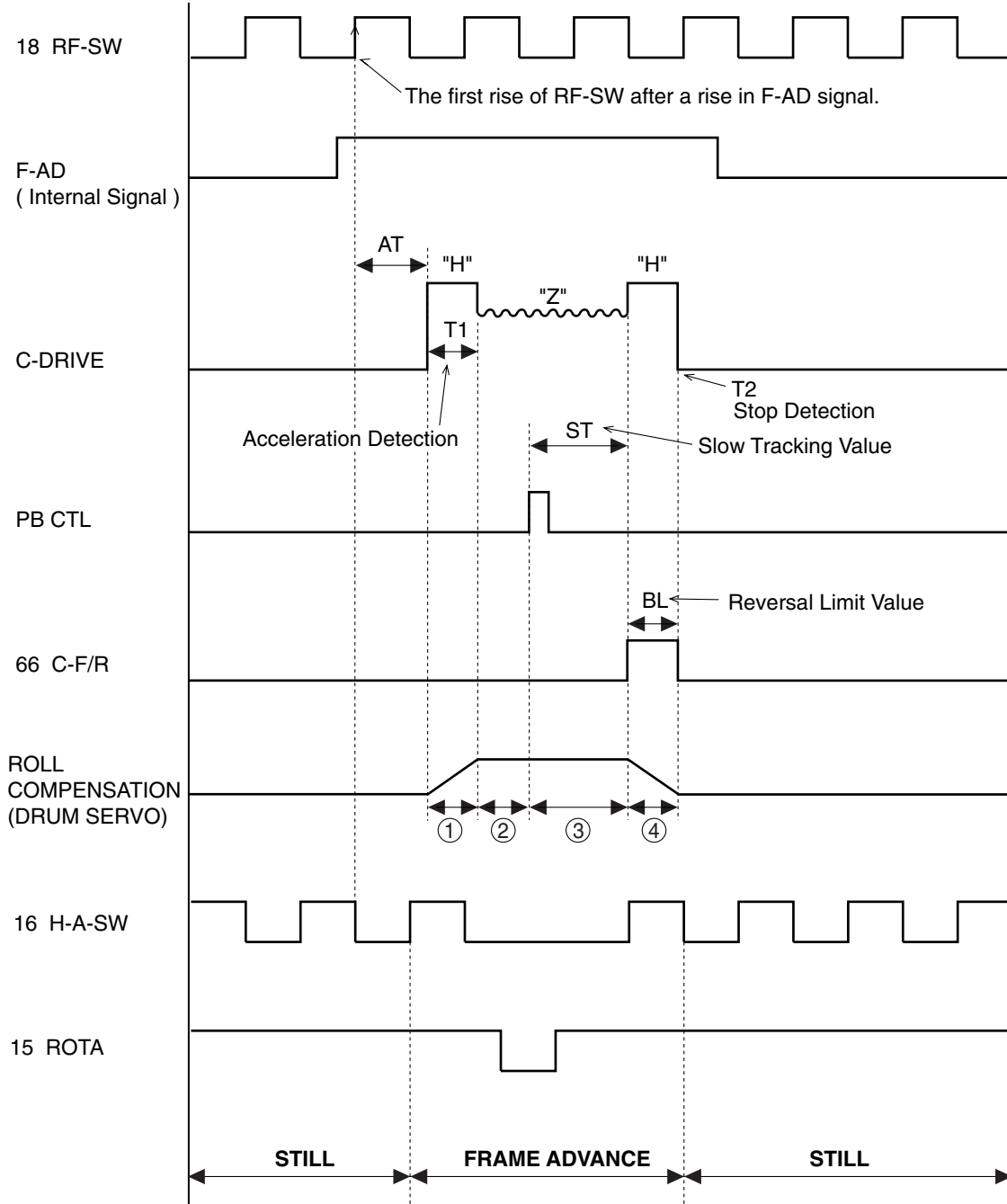

Fig. 1

Chart 2

2) LP/EP MODE

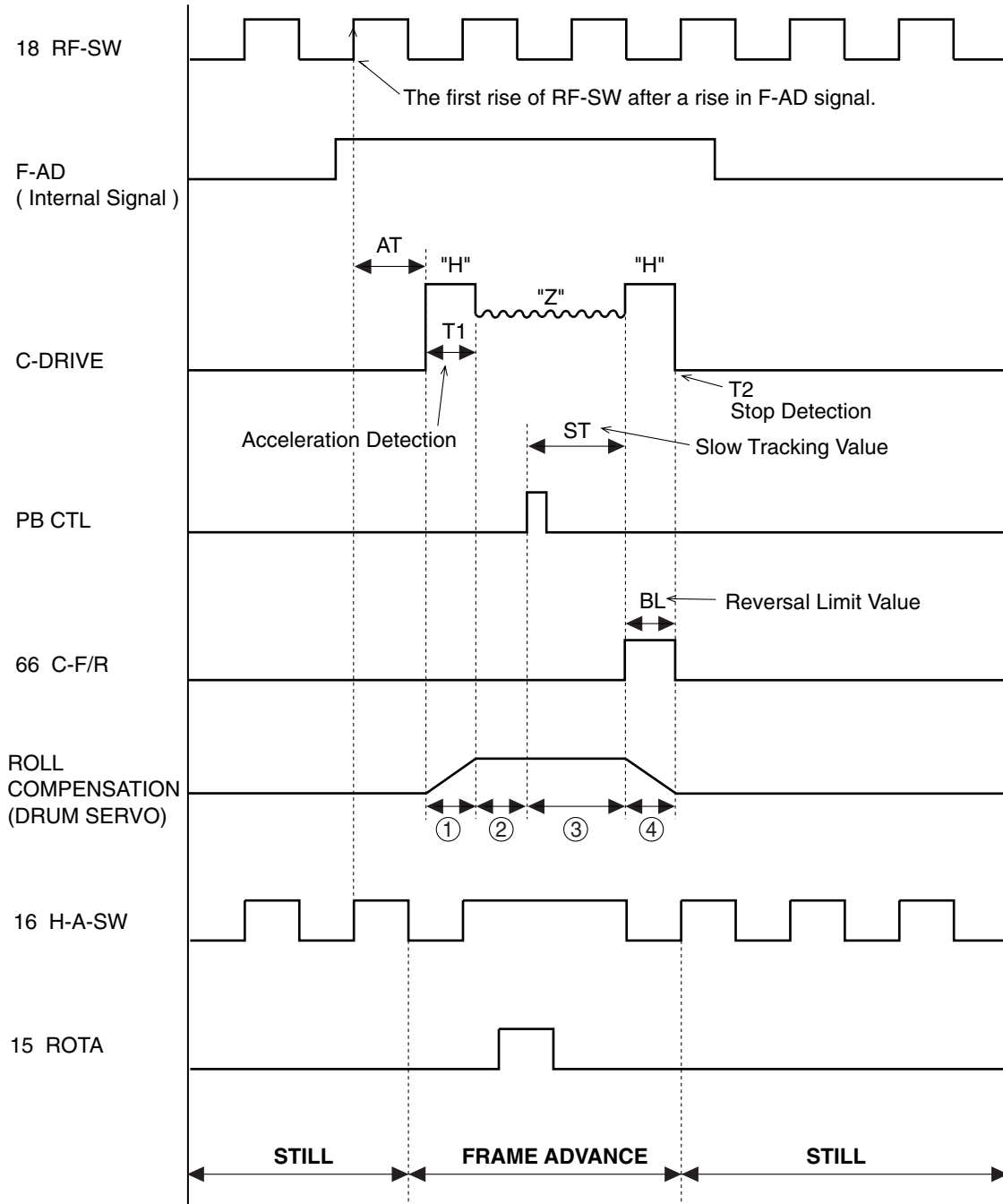

Fig. 2

Chart 3

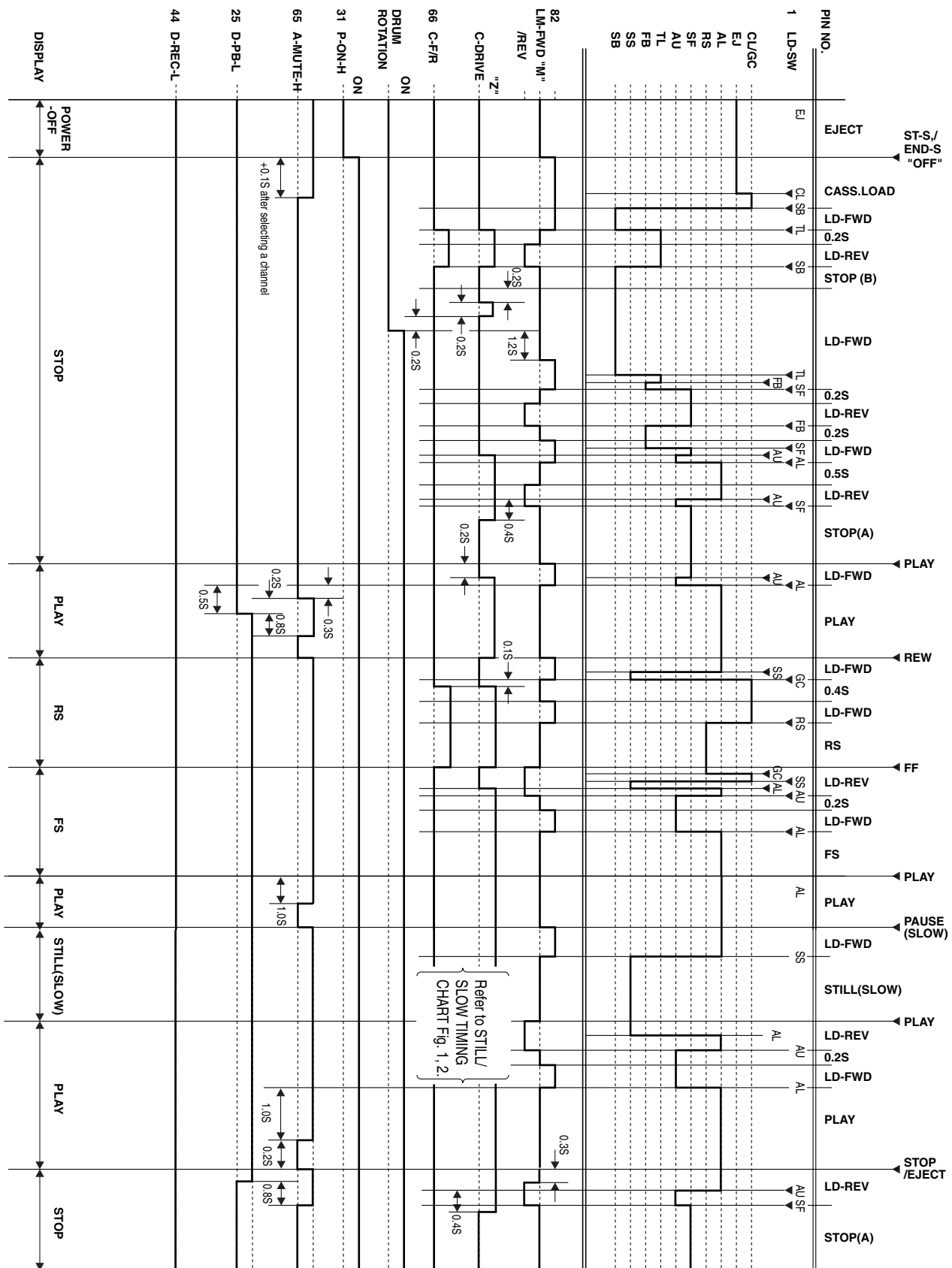

Fig. 3

Chart 4

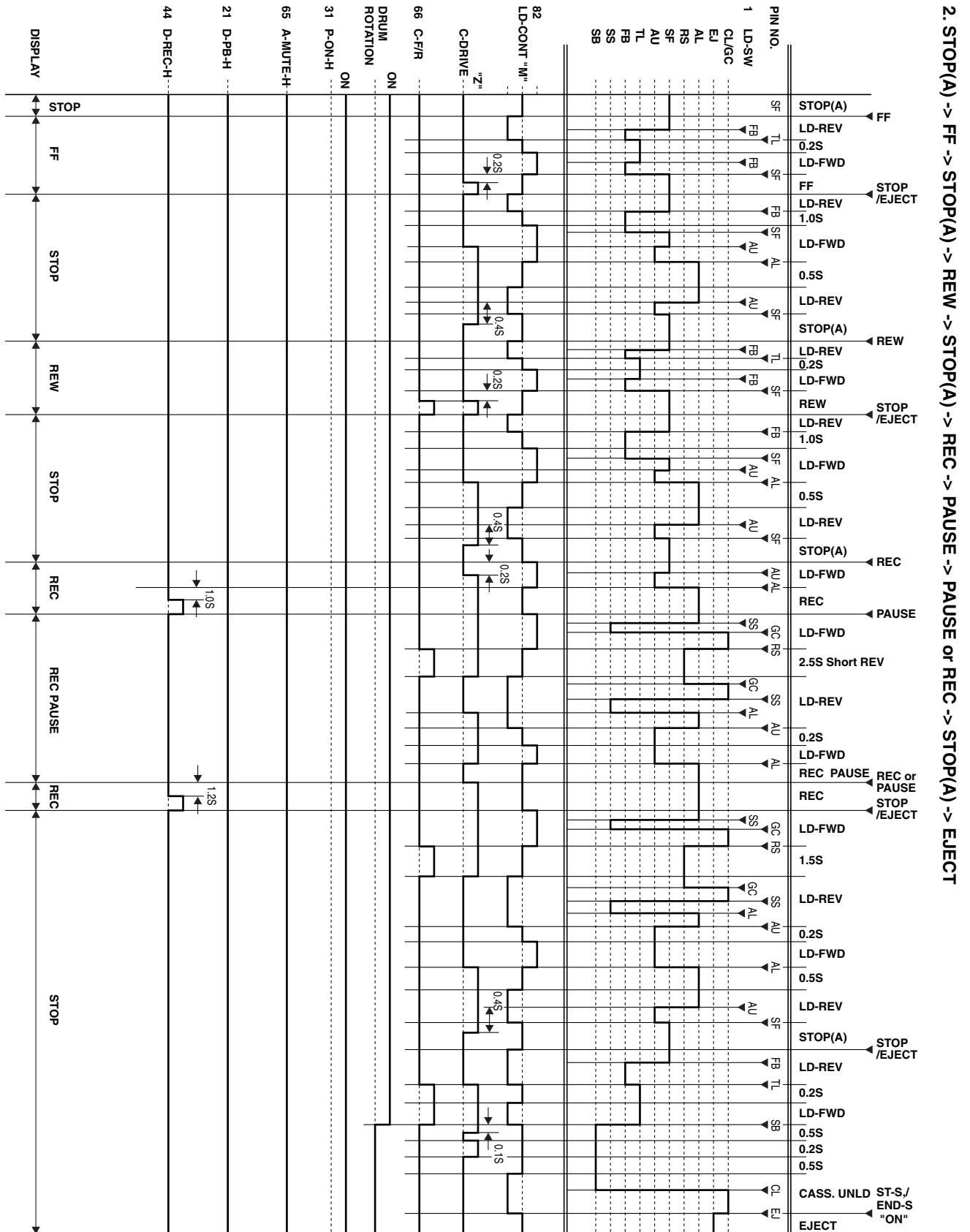

Fig. 4

IC PIN FUNCTION DESCRIPTIONS

IC 201 (TV/VCR Micro Computer)

“H” ≥ 4.5V, “L” ≤ 1.0V

Pin No.	IN/OUT	Signal Name	Function
1	IN	LD-SW	Loading Switch Input
2	IN	P-SAFETY 1	Power Supply Failure Detection 1
3	IN	P-SAFETY 2	Power Supply Failure Detection 2
4	IN	P-SAFETY 3	Power Supply Failure Detection 3
5	IN	KEY0	Key 0 Input
6	IN	KEY1	Key 1 Input
7	IN	END-SENS	End-Sensor
8	-	NU	Not Used
9	IN	ST-SENS	Start-Sensor
10	IN	V-ENV	Video Envelope Input
11	-	NU	Not Used
12	OUT	SP-MUTE	Speaker Mute Output
13	IN/OUT	D-V SYNC	Artificial V-Sync Output
14	IN	REMOTE	Remote Signal Input
15	OUT	ROTA	Color Phase Rotary Changeover Signal
16	OUT	V-H-SW	Video Head Amp Switching Pulse
17	IN	ENV-DET	Envelope Comparator Signal
18	OUT	RF-SW	Video Head Switching Pulse
19	-	NU	Not Used
20	OUT	EXT-L	External Input or Playback = Output
21	-	NU	Not Used
22	OUT	REC-LED	Recording LED Control Signal
23	OUT	REC-LED	Recording LED Control Signal
24	-	NU	Not Used
25	-	NU	Not Used
26	-	NU	Not Used
27	IN/OUT	REC/EE/PB	YCA IC Mode Output

Pin No.	IN/OUT	Signal Name	Function
28	IN/OUT	TAPE-SPEED	Tape Speed Control Output
29	OUT	EXT-H/INSEL	External Input or Playback Signal Output/Input Selector Control Signal
30	IN/OUT	RENTAL	Rental Position Control Signal
31	OUT	P-ON-H	Power On Signal at High
32	OUT	SPL-PLAY	Special Playback Control Signal
33	IN	REC-SAFETY	Record Protection Tab Detection
34	IN	RESET	System Reset Signal (Reset="L")
35	IN	XC-IN	Sub Clock 32 kHz
36	OUT	XC-OUT	Sub Clock 32 kHz
37	-	TIMER+5V	Vcc
38	IN	X-IN	Main Clock Input
39	OUT	X-OUT	Main Clock Output
40	-	GND	GND
41	OUT	SPOT-KILL	Counter-measure for Spot
42	-	NU	Not Used
43	IN	CLKSEL	Clock Select (GND)
44	OUT	D-REC-H	Delayed Record Signal
45	IN	I2C-OPEN	White Balance Adjust Mode Judgment
46	-	GND	GND
47	-	NU	Not Used
48	-	NU	Not Used
49	-	GND	OSD GND
50	-	NU	Not Used
51	-	NU	Not Used
52	-	NU	Not Used
53	-	P-ON+5V	OSD Vcc
54	-	HLF	HLF
55	IN	V-HOLD	VHOLD
56	IN	CV-IN	Video Signal Input
57	-	GND	GND
58	IN	H-SYNC	H-SYNC Input
59	IN	V-SYNC	V-SYNC Input

Pin No.	IN/OUT	Signal Name	Function
60	OUT	OSD-BLK	Output for Picture Cut off
61	-	NU	Not Used
62	OUT	OSD-B	Blue Output
63	OUT	OSD-G	Green Output
64	OUT	OSD-R	Red Output
65	OUT	A-MUTE	Audio Mute Output
66	OUT	C-F/R	Capstan Motor FWD/REV Control Signal
67	-	NU	Not Used
68	-	NU	Not Used
69	-	NU	Not Used
70	-	NU	Not Used
71	OUT	SCL	E2PROM/CHROMA IC Tuner Communication Clock
72	IN/OUT	SDA	E2PROM/CHROMA IC Tuner Communication Data
73	-	NU	Not Used
74	IN	C-SYNC	C-Sync Input
75	-	NU	Not Used
76	OUT	C-CONT	Capstan Motor Control Signal
77	OUT	D-CONT	Drum Motor Control Signal
78	-	NU	Not Used
79	-	NU	Not Used
80	IN	T-REEL	Take Up Reel Rotation Signal
81	-	NU	Not Used
82	OUT	LD-CONT	Loading Motor Control Signal
83	-	NU	Not Used
84	OUT	P-DOWN	Power Voltage Down Detector Signal
85	-	NU	Not Used
86	-	NU	Not Used
87	IN	C-FG	Capstan Motor Rotation Detection Pulse
88	-	GND	GND (AMP)
89	IN	D-FG	Drum Motor Rotation Detection Pulse

Pin No.	IN/OUT	Signal Name	Function
90	IN	D-PG	Drum Motor Pulse Generator
91	-	NU	Not Used
92	OUT	AMP VREF OUT	Standard Voltage Output
93	IN	AMP VREF IN	Standard Voltage Input
94	IN/OUT	CTL (-)	CTL (-)
95	IN/OUT	CTL (+)	CTL (+)
96	-	AMPC	AMPC
97	OUT	CTL AMP OUT	Control Amp Output
98	-	P-ON+5V	Power Supply for AMP
99	-	AL+5V	A/D, D/A Standard Voltage
100	IN	X-RAY	X-Ray Protection

LEAD IDENTIFICATIONS

2SK2662

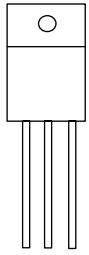

S D G

S: Souce
D: Drain
G: Gate

2SD2627LS-FEC-YB11
TT2084LS-YB11

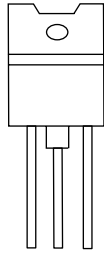

B C E

E: Emitter
C: Collector
B: Base

PT204-6B-12
MID-32A22

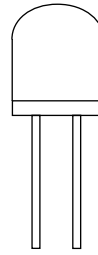

E C

2SD400(F)

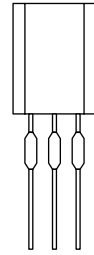

E C B

LA78040A
AN5522

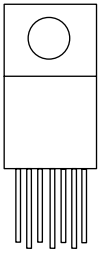

IN G OUT

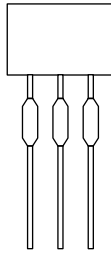

E C B

KRA103M
2SA1346
2SC1815-GR(TPE2)
2SC3331(T,U)
2SC2120-(O,Y)(TPE2)
KTC3203(Y)
KTA1266(GR)

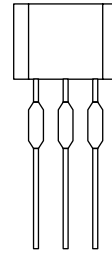

E C B

2SC1627Y-TPE2
2SA950(Y,O)
KTA1271(Y)
2SC2482 TPE6
2SC3468(E,D)-AE
KTC3207
2SA1175(F)
KTA1267(GR)
KTC3198(GR)
BN1F4M-T
KTC3199(GR)
2SC2785(J,H,F)
2SA1015-GR(TPE2)

KIA7805API
KA7805A
AN7805F

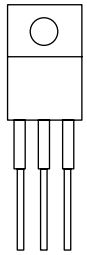

IN G OUT

LTV-817(B,C)-F
PC817X6



M37760M8H1D8GP
LA71091M

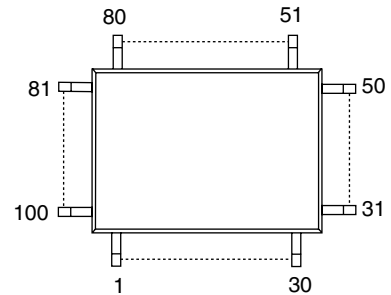

BR24C02F-W
BR24C02F
AT24C02N-10SC
M24C02-MN6

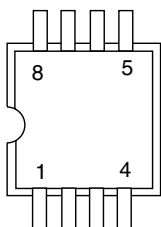

LA4224

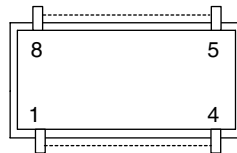

M61210FP-R60*
M612106FP-R61
M612106FP-R62*

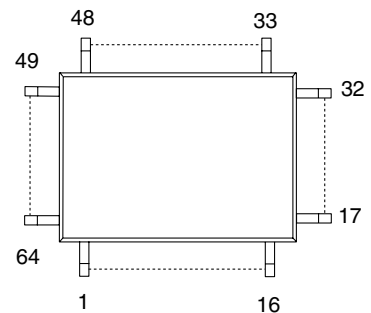

DECK MECHANISM SECTION

13" COLOR TV/VCR COMBINATION

SSC132

Sec. 2: Deck Mechanism Section

- Standard Maintenance
- Alignment for Mechanism
- Disassembly/Assembly of Mechanism
- Alignment Procedures of Mechanism

TABLE OF CONTENTS

Standard Maintenance	2-1-1
Service Fixtures and Tools	2-2-1
Mechanical Alignment Procedures	2-3-1
Disassembly / Assembly Procedures of Deck Mechanism	2-4-1
Alignment Procedures of Mechanism	2-4-9

STANDARD MAINTENANCE

Service Schedule of Components

H: Hours ○: Check ●: Change

Deck		Periodic Service Schedule			
Ref.No.	Part Name	1,000 H	2,000 H	3,000 H	4,000 H
B2	Cylinder Assembly	○	●	○	●
B3	Loading Motor Assembly			●	
B8	Pulley Assembly		●		●
B27	Tension Lever Sub Assembly		●		●
B31	AC Head Assembly			●	
B573,B574	Reel S, Reel T			●	
B37	Capstan Motor		●		●
B52	Cap Belt		●		●
*B73	FE Head			●	
B133	Idler Assembly		●		●
B410	Pinch Arm (A) Assembly		●		●
B414	M Brake S Assembly		●		●
B416	M Brake T Assembly		●		●
B525	LDG Belt		●		●

Notes:

- 1.Clean all parts for the tape transport (Upper Drum with Video Head / Pinch Roller / Audio Control Head / Full Erase Head) using 90% Isopropyl Alcohol.
 - 2.After cleaning the parts, do all DECK ADJUSTMENTS.
 - 3.For the reference numbers listed above, refer to Deck Exploded Views.
- * B73 ----- Recording Model only

Cleaning

Cleaning of Video Head

Clean the head with a head cleaning stick or chamois cloth.

Procedure

1. Remove the top cabinet.
2. Put on a glove (thin type) to avoid touching the upper and lower drum with your bare hand.
3. Put a few drops of 90% Isopropyl alcohol on the head cleaning stick or on the chamois cloth and, by slightly pressing it against the head tip, turn the upper drum to the right and to the left.

Notes:

1. The video head surface is made of very hard material, but since it is very thin, avoid cleaning it vertically.
2. Wait for the cleaned part to dry thoroughly before operating the unit.
3. Do not reuse a stained head cleaning stick or a stained chamois cloth.

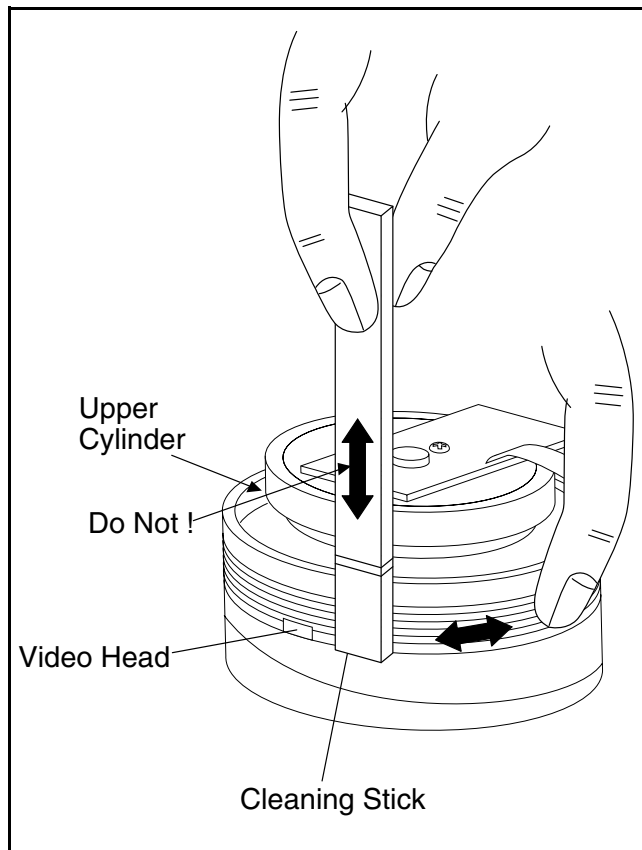

Cleaning of Audio Control Head

Clean the head with a cotton swab.

Procedure

1. Remove the top cabinet.
2. Dip the cotton swab in 90% isopropyl alcohol and clean the audio control head. Be careful not to damage the upper drum and other tape running parts.

Notes:

1. Avoid cleaning the audio control head vertically.
2. Wait for the cleaned part to dry thoroughly before operating the unit or damage may occur.

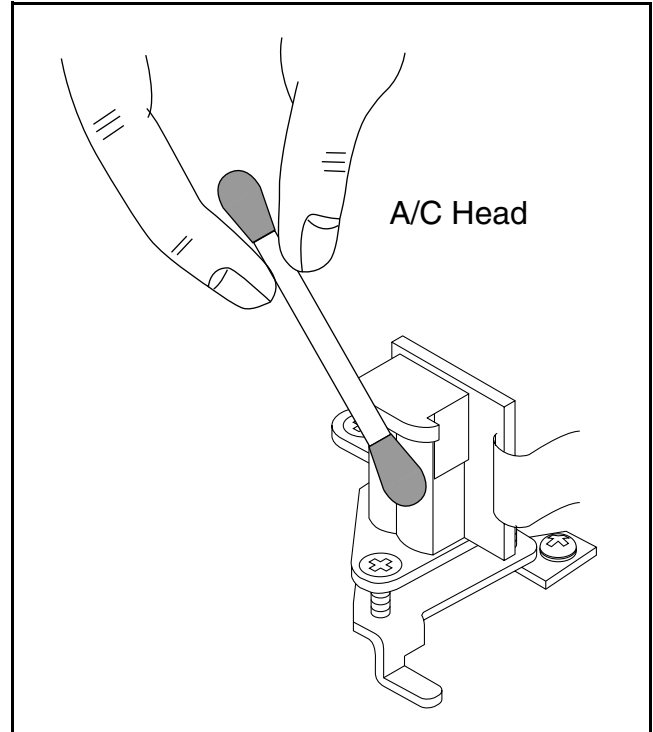

SERVICE FIXTURE AND TOOLS

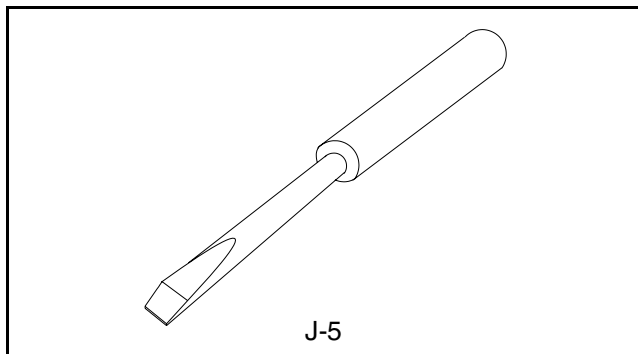
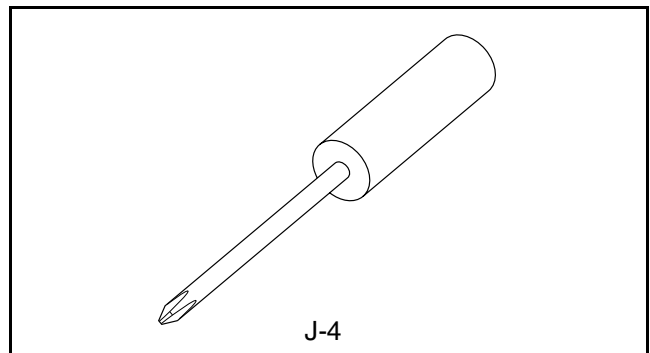
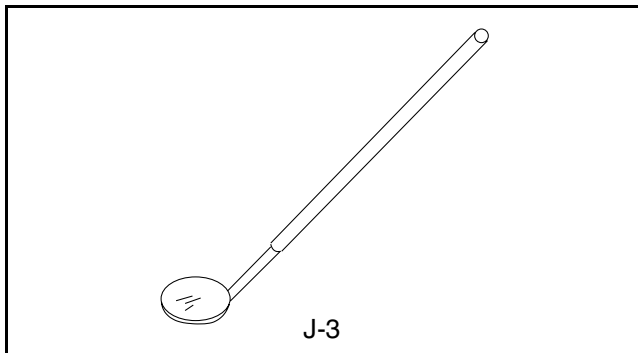
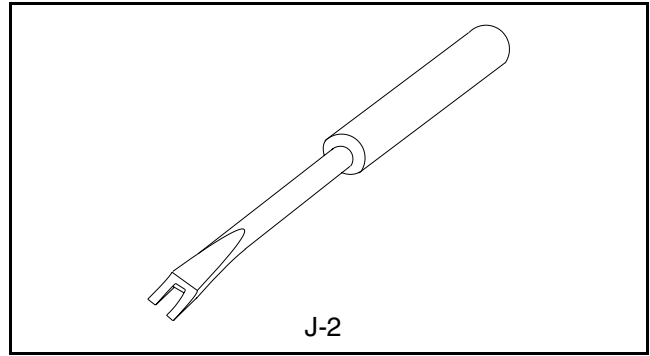
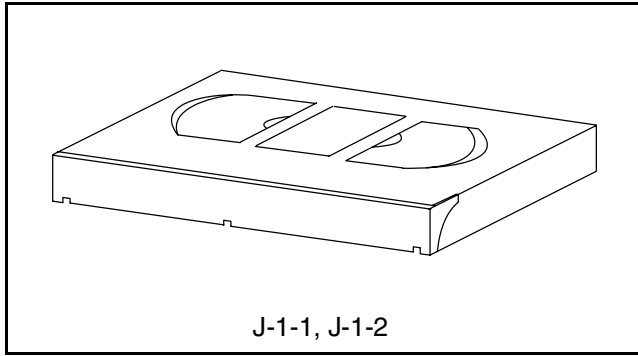

Ref. No.	Name	Part No.	Adjustment
J-1-1	Alignment Tape	FL8A	Head Adjustment of Audio Control Head
J-1-2	Alignment Tape	FL8N (2Head only) FL8NW (4Head only)	Azimuth and X Value Adjustment of Audio Control Head / Adjustment of Envelope Waveform
J-2	Guide Roller Adj.Screwdriver	Available Locally	Guide Roller
J-3	Mirror	FSJ-0004	Tape Transportation Check
J-4	Azimuth Adj.Screwdriver +	Available Locally	A/C Head Height
J-5	X Value Adj.Screwdriver -	Available Locally	X Value

MECHANICAL ALIGNMENT PROCEDURES

Explanation of alignment for the tape to correctly run starts on the next page. Refer to the information below on this page if a tape gets stuck, for example, in the mechanism due to some electrical trouble of the unit.

Service Information

A. Method for Manual Tape Loading/Unloading

To load a cassette tape manually:

1. Disconnect the AC plug.
2. Remove the Top Case and Front Assembly.
3. Insert a cassette tape. Though the tape will not be automatically loaded, make sure that the cassette tape is all the way in at the inlet of the Cassette Holder. To confirm this, lightly push the cassette tape further in and see if the tape comes back out, by a spring motion, just as much as you have pushed in.
4. Turn the LDG Belt in the appropriate direction shown in Fig. M1 for a minute or two to complete this task.

To unload a cassette tape manually:

1. Disconnect the AC plug.
2. Remove the Top Case and Front Assembly.
3. Make sure that the Moving guide preparations are in the Eject Position.
4. Turn the LDG Belt in the appropriate direction shown in Fig. M1 until the Moving guide preparations come to the Eject Position. Stop turning when the preparations begin clicking or can not be moved further. However, the tape will be left wound around the cylinder.
5. Turn the LDG Belt in the appropriate direction continuously, and the cassette tape will be ejected. Allow a minute or two to complete this task.

B. Method to place the Cassette Holder in the tape-loaded position without a cassette tape

1. Disconnect the AC Plug.
2. Remove the Top Case and Front Assembly.
3. Turn the LDG Belt in the appropriate direction shown in Fig. M1. Release the locking tabs shown in Fig. M1 and continue turning the LDG Belt until the Cassette Holder comes to the tape-loaded position. Allow a minute or two to complete this task.

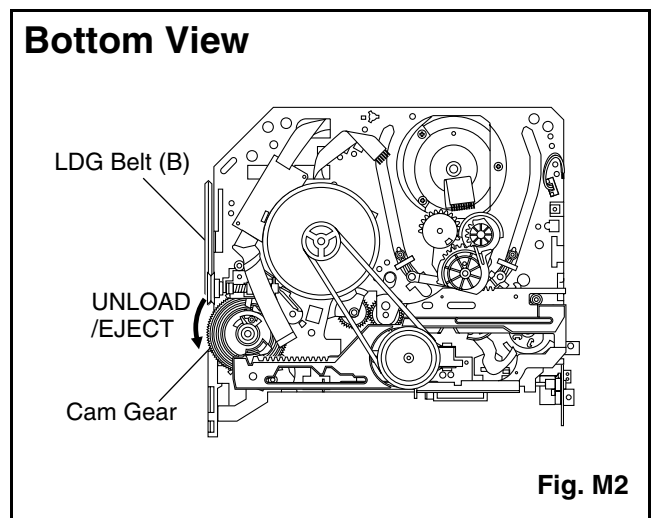
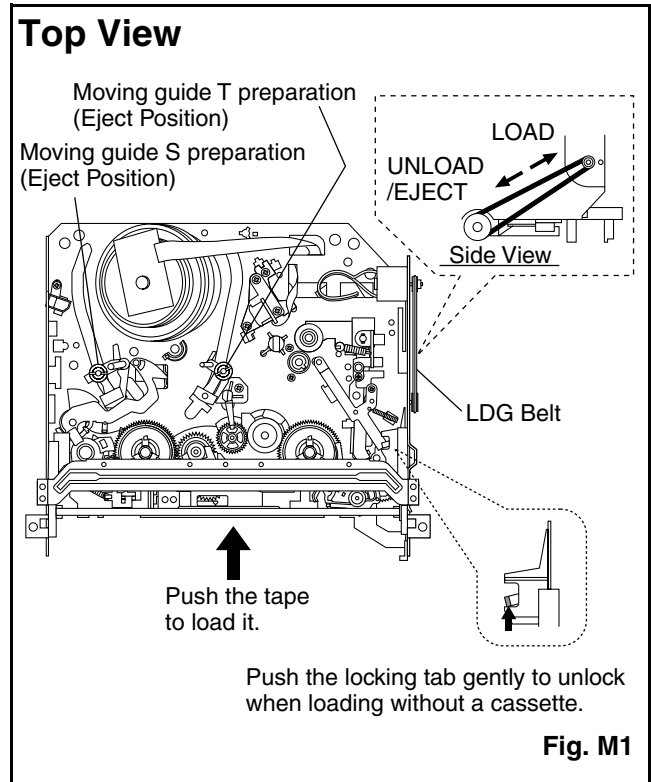

1.Tape Interchangeability Alignment

Note:

To do these alignment procedures, make sure that the Tracking Control Circuit is set to the center position every time a tape is loaded or unloaded. (Refer to page 2-3-4, procedure 1-C, step 2.)

Equipment required:

- Dual Trace Oscilloscope
- VHS Alignment Tape (FL8NW)
- Guide Roller Adj. Screwdriver
- X-Value Adj. Screwdriver

Note: Before starting this Mechanical Alignment, do all Electrical Adjustment procedures.

Flowchart of Alignment for tape traveling

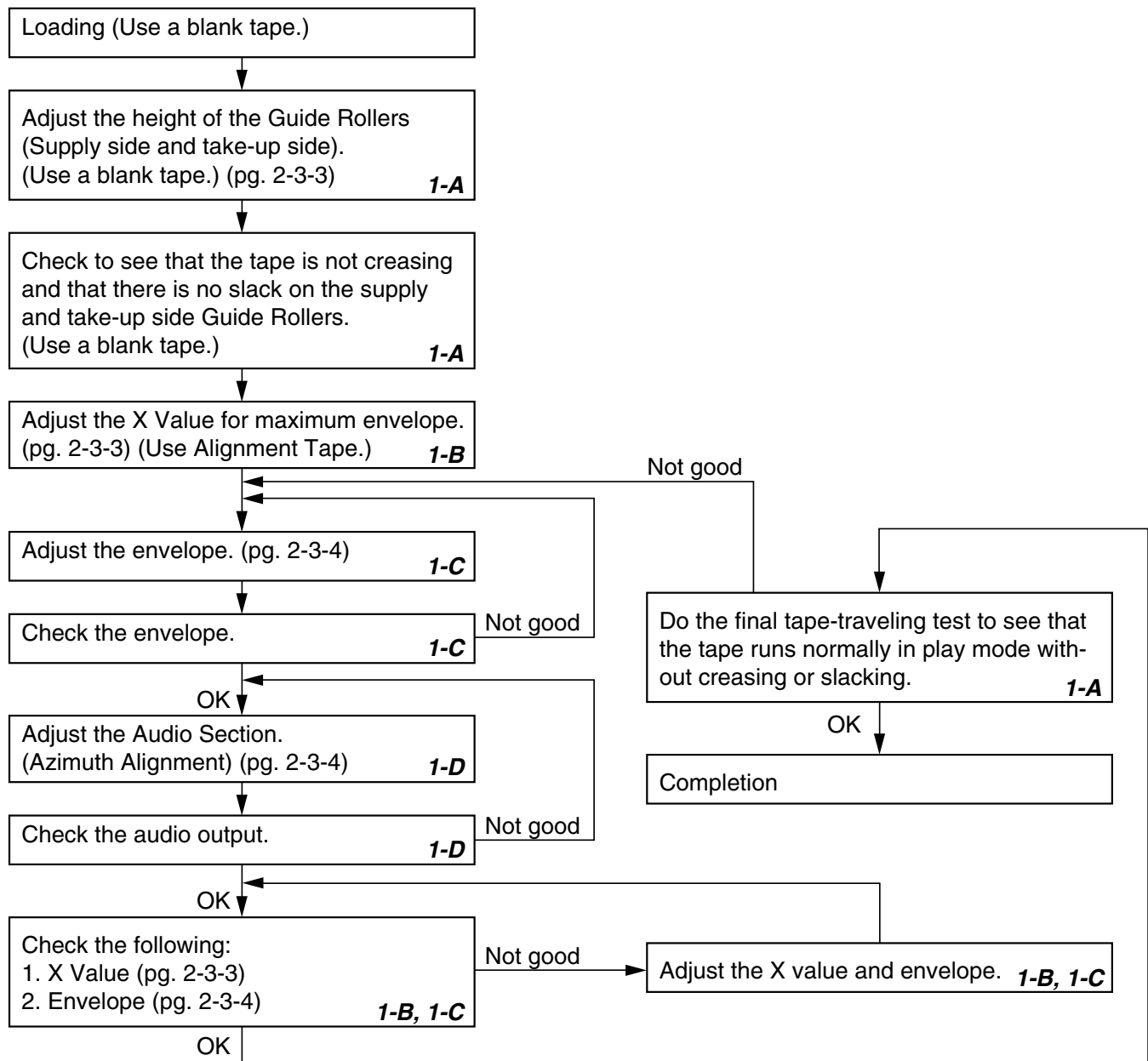

1-A. Preliminary/Final Checking and Alignment of Tape Path

Purpose:

To make sure that the tape path is well stabilized.

Symptom of Misalignment:

If the tape path is unstable, the tape will be damaged.

Note: Do not use an Alignment Tape for this procedure. If the unit is not correctly aligned, the tape may be damaged.

1. Play back a blank cassette tape and check to see that the tape runs without creasing at Guide Rollers [2] and [3], and at points A and B on the lead surface. (Refer to Fig M3 and M4.)
2. If creasing is apparent, align the height of the guide rollers by turning the top of Guide Rollers [2] and [3] with a Guide Roller Adj. Screwdriver. (Refer to Fig. M3 and M5.)

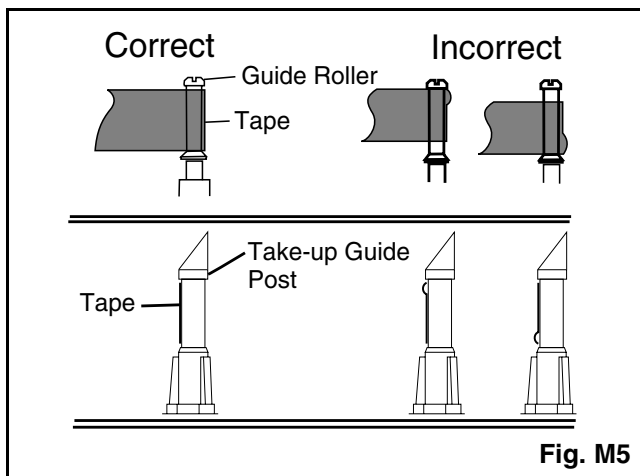
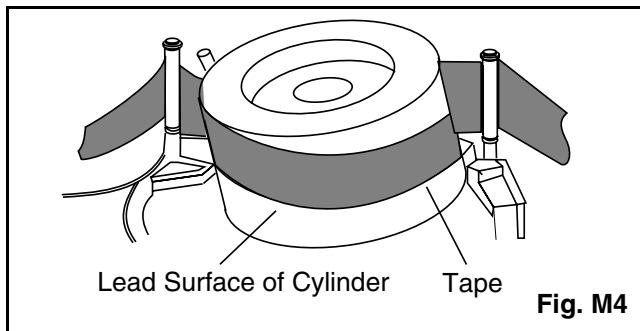
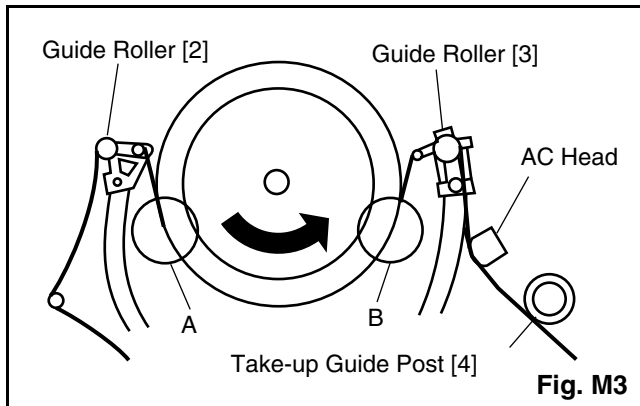

3. Check to see that the tape runs without creasing at Take-up Guide Post [4] or without snaking between Guide Roller [3] and AC Head. (Fig. M3 and M5)
4. If creasing or snaking is apparent, adjust the Tilt Adj. Screw of the AC Head. (Fig. M6)

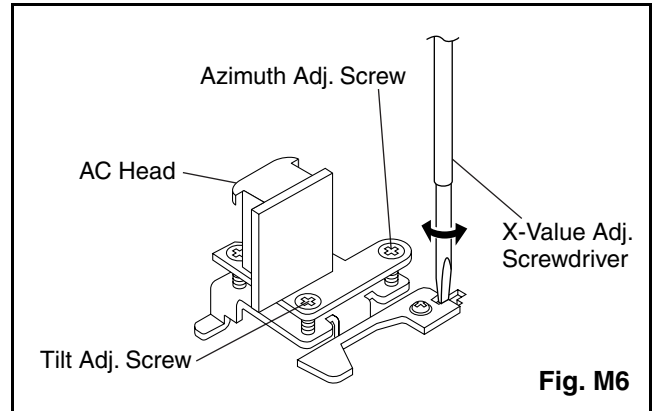

1-B. X Value Alignment

Purpose:

To align the Horizontal Position of the Audio/Control/ Erase Head.

Symptom of Misalignment:

If the Horizontal Position of the Audio/Control/Erase Head is not properly aligned, maximum envelope cannot be obtained at the Neutral position of the Tracking Control Circuit.

1. Connect the oscilloscope to J189 (PB-C-MONI) and J116 (CTL) on the Main CBA. Use J190 (RF-SW) as a trigger.
2. Play back the Gray Scale of the Alignment Tape (FL8NW) and confirm that the PB FM signal is present.
3. Set the Tracking Control Circuit to the center position by pressing CH UP button then "PLAY" button on the unit. (Refer to note on bottom of page 2-3-4.)
4. Use the X-Value Adj. Screwdriver so that the PB FM signal at J189 (PB-C-MONI) is maximum. (Fig. M6)
5. Press CH UP button on the unit until the CTL waveform has shifted by approx. +2msec. Make sure that the envelope is simply attenuated (shrinks in height) during this process so that you will know the envelope has been at its peak.

- Press CH DOWN button on the unit until the CTL waveform has shifted from its original position (not the position achieved in step 5, but the position of CTL waveform in step 4) by approximately -2msec. Make sure that the envelope is simply attenuated (shrinks in height) once CTL waveform passes its original position and is further brought in the minus direction.
- Set the Tracking Control Circuit to the center position by pressing CH UP button and then "PLAY" button on the unit.

1-C. Checking/Adjustment of Envelope Waveform

Purpose:

To achieve a satisfactory picture and precise tracking.

Symptom of Misalignment:

If the envelope output is poor, noise will appear in the picture. The tracking will then lose precision and the playback picture will be distorted by any slight variation of the Tracking Control Circuit.

- Connect the oscilloscope to J189 (PB-C-MONI) on the Main CBA. Use J190 (RF-SW) as a trigger.
- Play back the Gray Scale on the Alignment Tape (FL8NW). Set the Tracking Control Circuit to the center position by pressing CH UP button and then "PLAY" button on the unit. Adjust the height of Guide Rollers [2] and [3] (Fig. M3, Page 2-3-3) watching the oscilloscope display so that the envelope becomes as flat as possible. To do this adjustment, turn the top of the Guide Roller with the Guide Roller Adj. Screwdriver.
- If the envelope is as shown in Fig. M7, adjust the height of Guide Roller [2] (Refer to Fig. M3) so that the waveform looks like the one shown in Fig. M9.
- If the envelope is as shown in Fig. M8, adjust the height of Guide Roller [3] (Refer to Fig. M3) so that the waveform looks like the one shown in Fig. M9.
- When Guide Rollers [2] and [3] (Refer to Fig. M3) are aligned properly, there is no envelope drop either at the beginning or end of track as shown in Fig. M9.

Note: Upon completion of the adjustment of Guide Rollers [2] and [3] (Refer to Fig. M3), check the X Value by pushing the CH UP or DOWN buttons alternately, to check the symmetry of the envelope. Check the number of pushes to ensure center position. The number of pushes CH UP button to achieve 1/2 level of envelope should match the number of pushes CH DOWN button from center. If required, redo the "X Value Alignment."

1-D. Azimuth Alignment of Audio/Control/Erase Head

Purpose:

To correct the Azimuth alignment so that the Audio/Control/Erase Head meets tape tracks properly.

Symptom of Misalignment:

If the position of the Audio/Control/Erase Head is not properly aligned, the Audio S/N Ratio or Frequency Response will be poor.

- Connect the oscilloscope to the audio output jack on the rear side of the deck.
- Play back the alignment tape (FL8NW) and confirm that the audio signal output level is 8kHz.
- Adjust Azimuth Adj. Screw so that the output level on the AC Voltmeter or the waveform on the oscilloscope is at maximum. (Fig. M6)

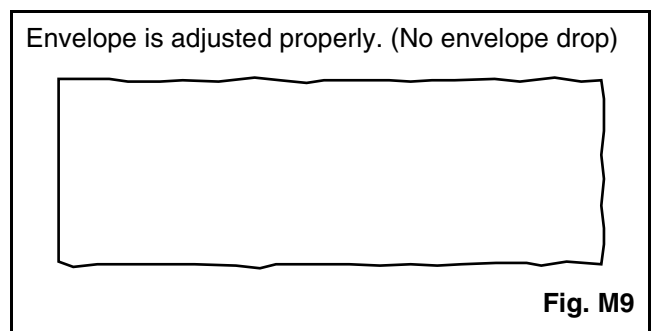
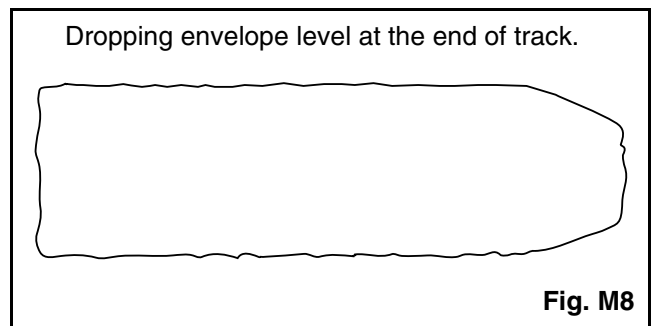
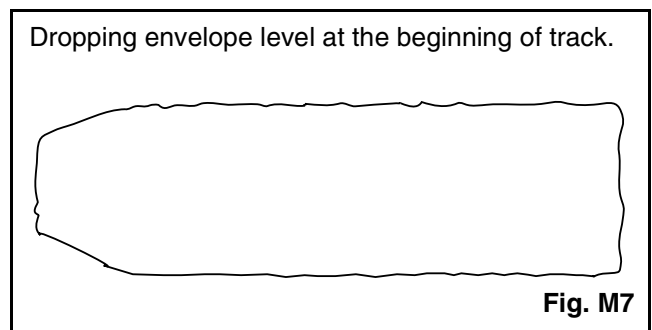

DISASSEMBLY/ASSEMBLY PROCEDURES OF DECK MECHANISM

Before following the procedures described below, be sure to remove the deck assembly from the cabinet. (Refer to CABINET DISASSEMBLY INSTRUCTIONS on page 1-6-1.)

All the following procedures, including those for adjustment and replacement of parts, should be done in Eject mode; see the positions of [41] and [42] in Fig.DM1 on page 2-4-3. When reassembling, follow the steps in reverse order.

STEP /LOC. No.	START-ING No.	PART		REMOVAL		INSTALLATION
				Fig. No.	REMOVE/*UNHOOK/ UNLOCK/RELEASE/ UNPLUG/DESOLDER	ADJUSTMENT CONDITION
[1]	[1]	Guide Holder A	T	DM3	2(S-1)	
[2]	[1]	Cassette Holder Assembly	T	DM4		
[3]	[2]	Slider L	T	DM5	(S-2)	
[4]	[2]	Slider R	T	DM5	(S-3)	
[5]	[4]	Lock Lever	T	DM5	(S-4),*(P-1)	
[6]	[2]	C Plate	T	DM5		
[7]	[7]	Cylinder Assembly	T	DM1,DM6	Desolder, 3(S-5)	
[8]	[8]	Loading Motor Assembly	T	DM1,DM7	Desolder, LDG Belt, 2(S-6)	
[9]	[9]	AC Head Assembly	T	DM1,DM7	(S-7)	
[10]	[2]	Tape Guide Assembly	T	DM1,DM8	*(P-2)	
[11]	[10]	Door Opener B	T	DM1,DM8	*(L-1),*(L-2)	
[12]	[11]	Pinch Arm (B)	T	DM1,DM8	*(P-3)	
[13]	[12]	Pinch Arm (A) Assembly	T	DM1,DM8		
[14]	[14]	FE Head	T	DM1,DM9	(S-8)	
[15]	[15]	Prism	T	DM1,DM9	(S-9)	
[16]	[2]	Slider Shaft	T	DM10	(S-10),*(L-3)	
[17]	[16]	C Drive Lever L	T	DM10		
[18]	[16]	C Drive Lever R	T	DM10		
[19]	[7],[10]	Capstan Motor	B	DM2,DM11	3(S-11), Cap Belt	
[20]	[20]	Clutch Assembly	B	DM2,DM12	(C-1)	
[21]	[20]	FF Arm	B	DM2,DM12		
[22]	[22]	Cam Holder F	B	DM2,DM13	(C-2)	
[23]	[23]	Cam Gear (B)	B	DM2,DM13	(C-3),*(P-4)	
[24]	[24]	Mode Gear	B	DM2,DM14	(C-4)	
[25]	[20],[23], [24]	Mode Lever	B	DM2,DM14	(C-5), *(L-4)	
[26]	[22]	Worm Holder	B	DM2,DM14	(S-12)	
[27]	[26]	Pully Assembly	B	DM2,DM14		
[28]	[25],[26]	Cam Gear (A)	B	DM2,DM14		
[29]	[25]	Idler Assembly	B	DM1,DM15	*(L-5)	
[30]	[25]	BT Arm	B	DM2,DM15	*(P-5)	
[31]	[25]	Loading Arm S (B) Assembly	B	DM2,DM15		(+)Refer to Alignment Sec.Pg.2-4-9
[32]	[31]	Loading Arm T (B) Assembly	B	DM2,DM15		(+)Refer to Alignment Sec.Pg.2-4-9

STEP /LOC. No.	START-ING No.	PART		REMOVAL		INSTALLATION
				Fig. No.	REMOVE/*UNHOOK/ UNLOCK/RELEASE/ UNPLUG/DESOLDER	ADJUSTMENT CONDITION
[33]	[2],[25]	M Brake T Assembly	T	DM1,DM16	*(P-6)	
[34]	[2],[25]	M Brake S Assembly	T	DM1,DM16	*(P-7)	
[35]	[34]	Tension Lever Sub Assembly	T	DM1,DM16		
[36]	[35]	T Lever Holder	T	DM1,DM16	*(L-6)	
[37]	[33]	M Gear	T	DM1,DM16	(C-6)	
[38]	[2],[15]	Sensor Gear	T	DM1,DM16	(C-7)	
[39]	[33]	Reel T	T	DM1,DM16		
[40]	[35]	Reel S	T	DM1,DM16		
[41]	[31],[35]	Moving Guide S Preparation	T	DM1,DM17		
[42]	[32]	Moving Guide T Preparation	T	DM1,DM17		
[43]	[19]	TG Post Assembly	T	DM1,DM17	*(L-7)	
[44]	[19],[28]	Rack Assembly	R	DM18		(+)Refer to Alignment Sec.Pg.2-4-10
[45]	[44]	F Door Opener	R	DM18		
[46]	[46]	Cleaner Lever Assembly	T	DM1,DM6	*(L-8)	
(1)	(2)	(3)	(4)	(5)	(6)	(7)

(1): Follow steps in sequence. When reassembling, follow the steps in reverse order.

These numbers are also used as Identification (location) No. of parts in the figures.

(2): Indicates the part to start disassembling with in order to disassemble the part in column (1).

(3): Name of the part

(4): Location of the part: T=Top B=Bottom R=Right L=Left

(5): Figure Number

(6): Identification of parts to be removed, unhooked, unlocked, released, unplugged, unclamped, or desoldered.

P=Spring, W=Washer, C=Cut Washer, S=Screw, *=Unhook, Unlock, Release, Unplug, or Desolder

e.g., 2(L-2) = two Locking Tabs (L-2).

(7): Adjustment Information for Installation

(+):Refer to Deck Exploded Views for lubrication.

Top View

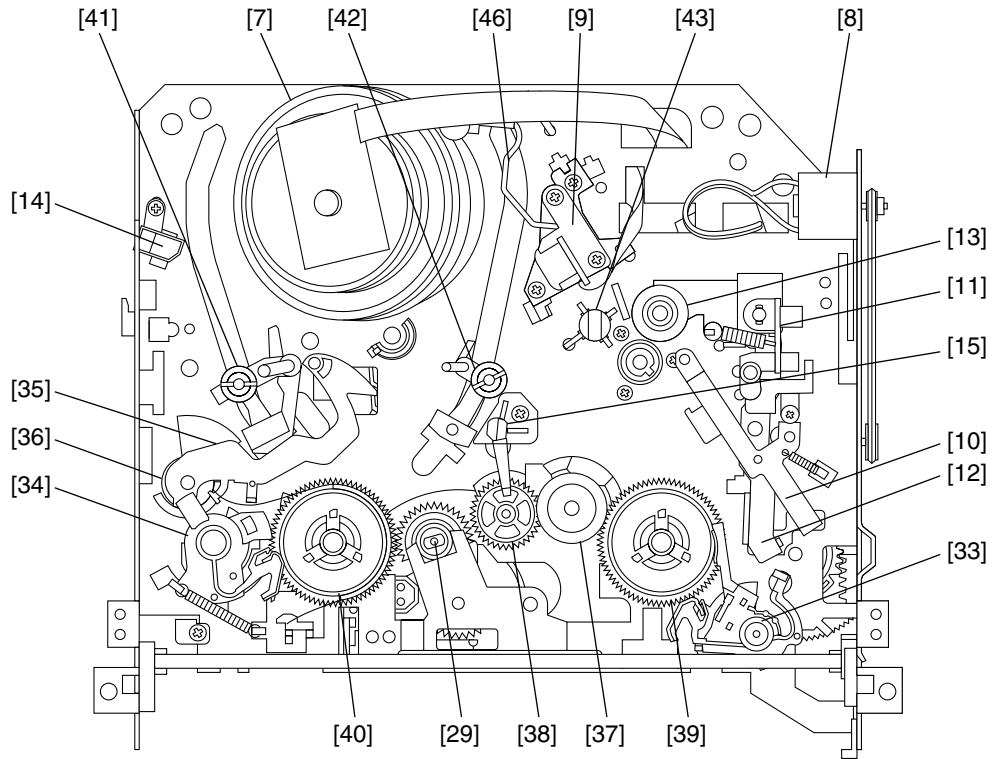

Fig. DM1

Bottom View

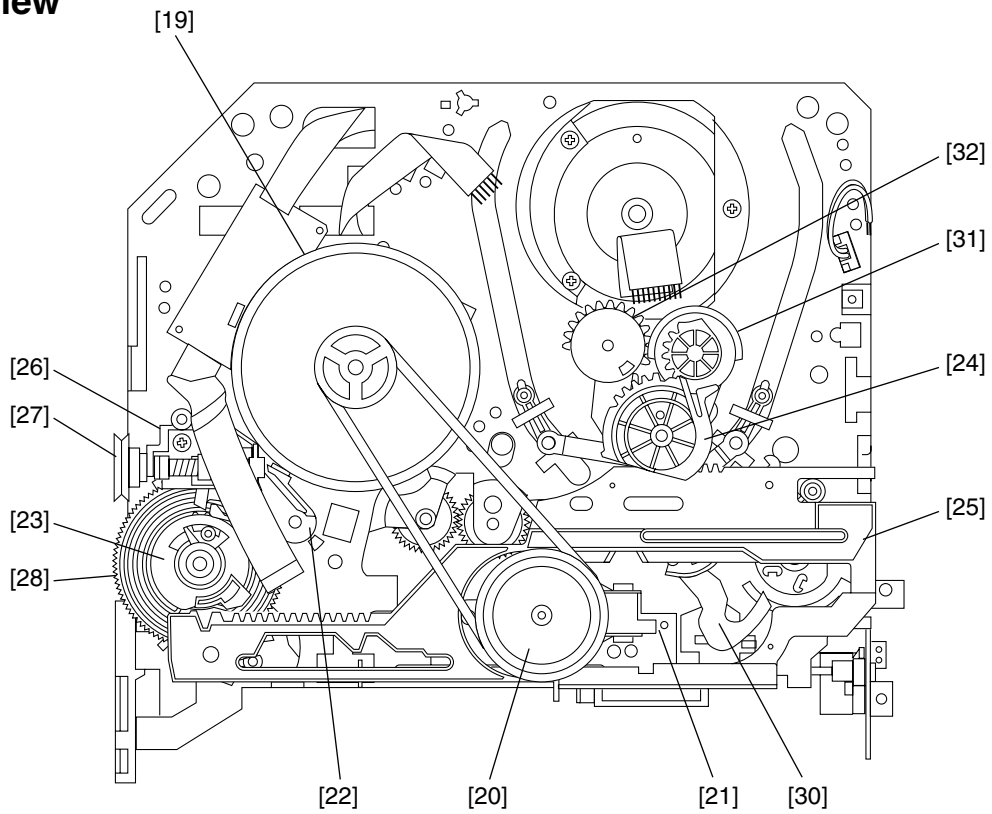

Fig. DM2

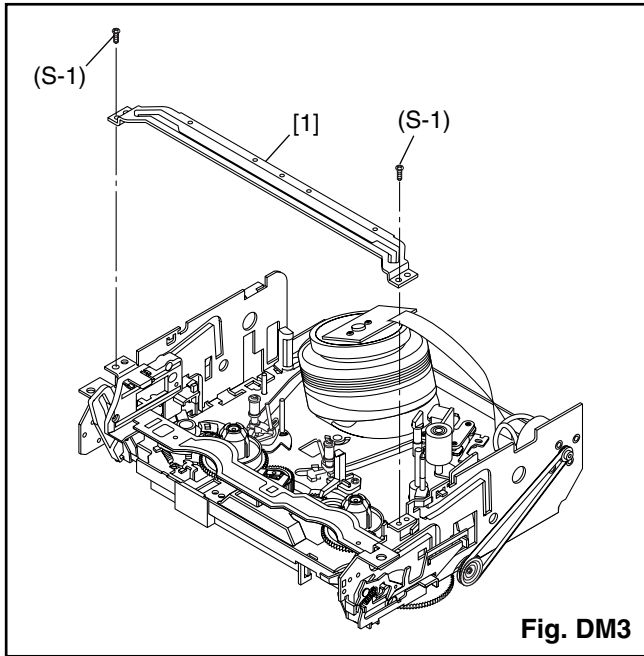

Fig. DM3

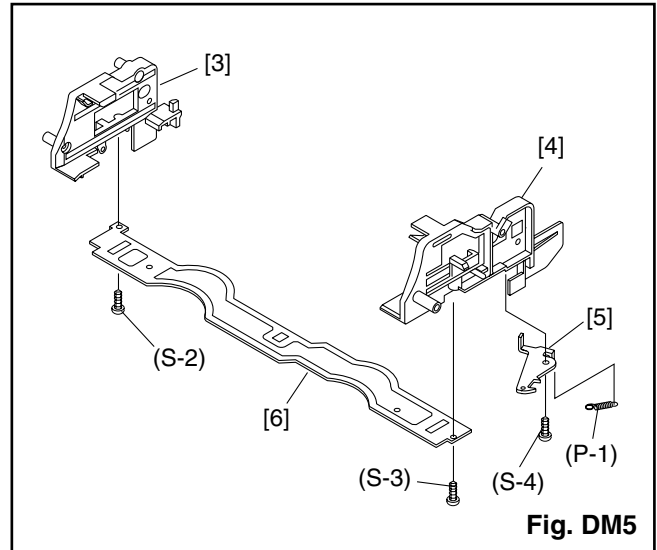

Fig. DM5

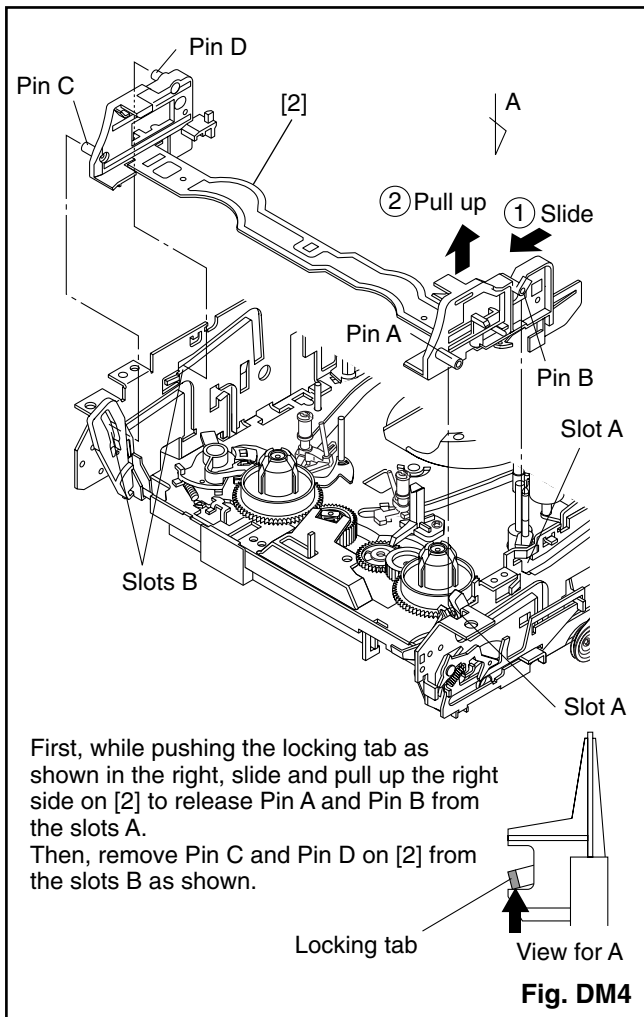

Fig. DM4

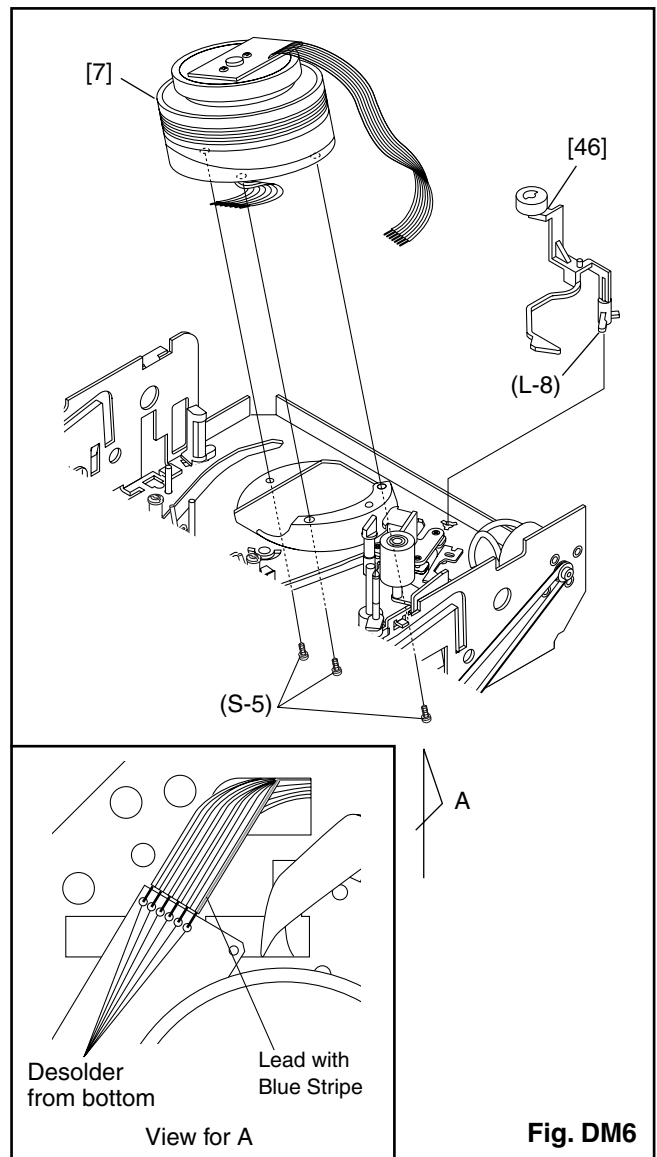
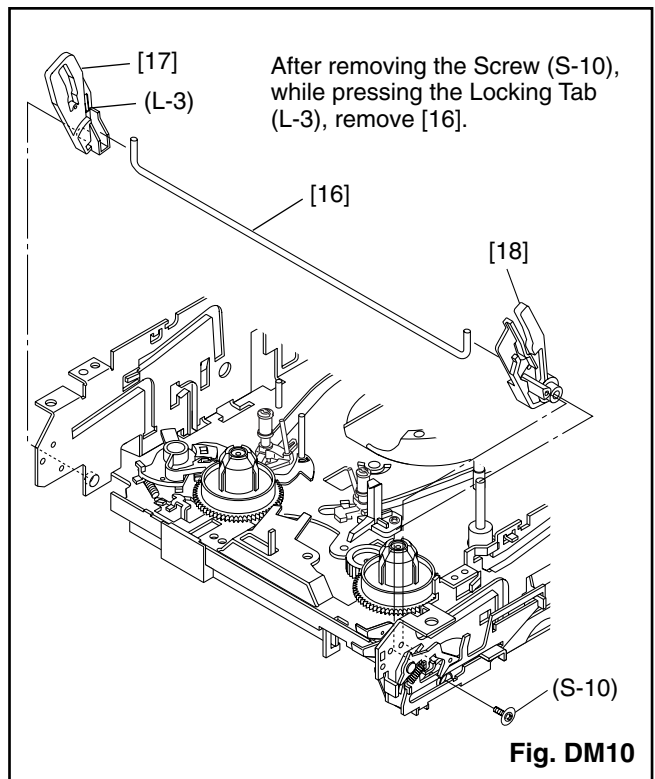
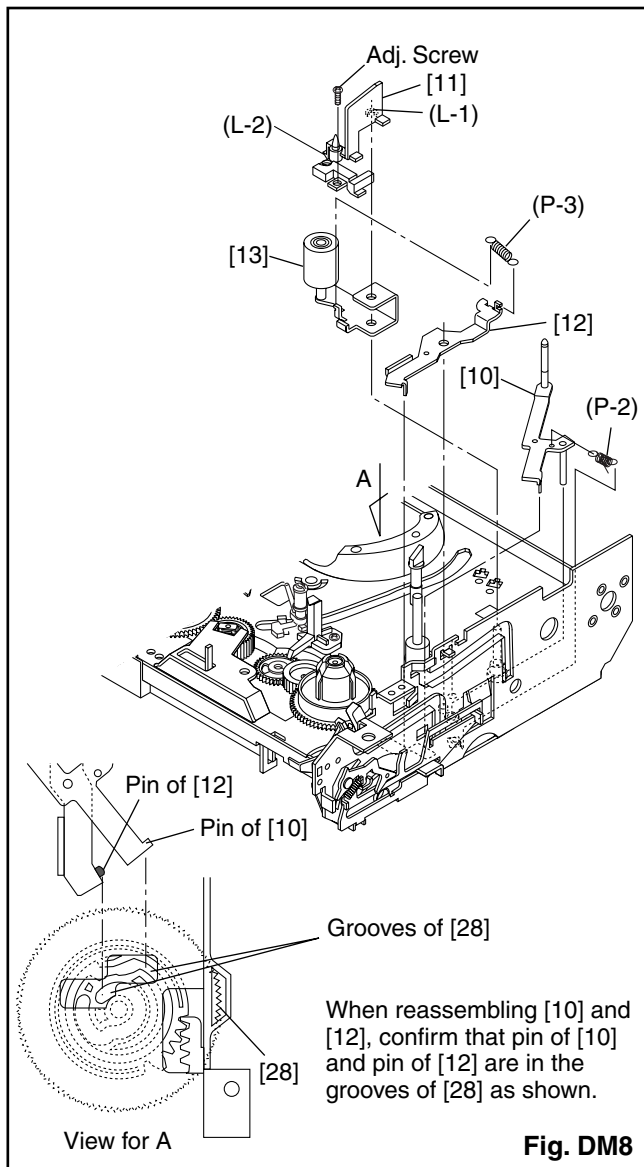
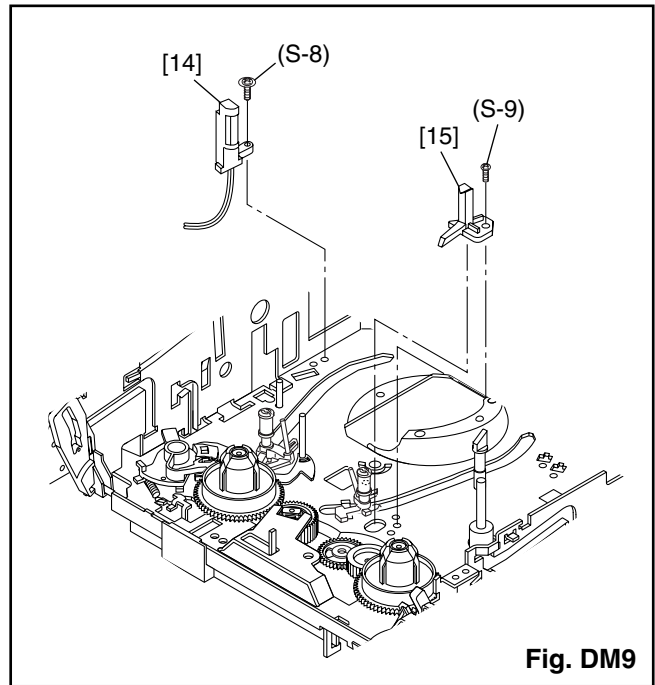
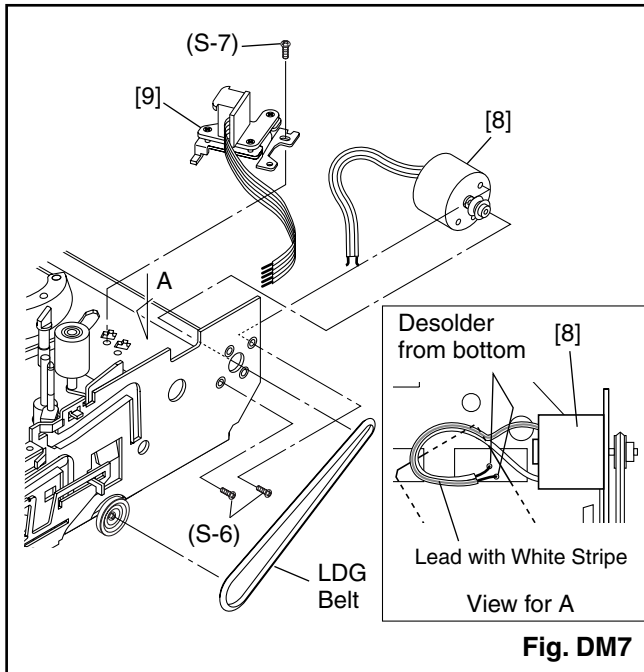
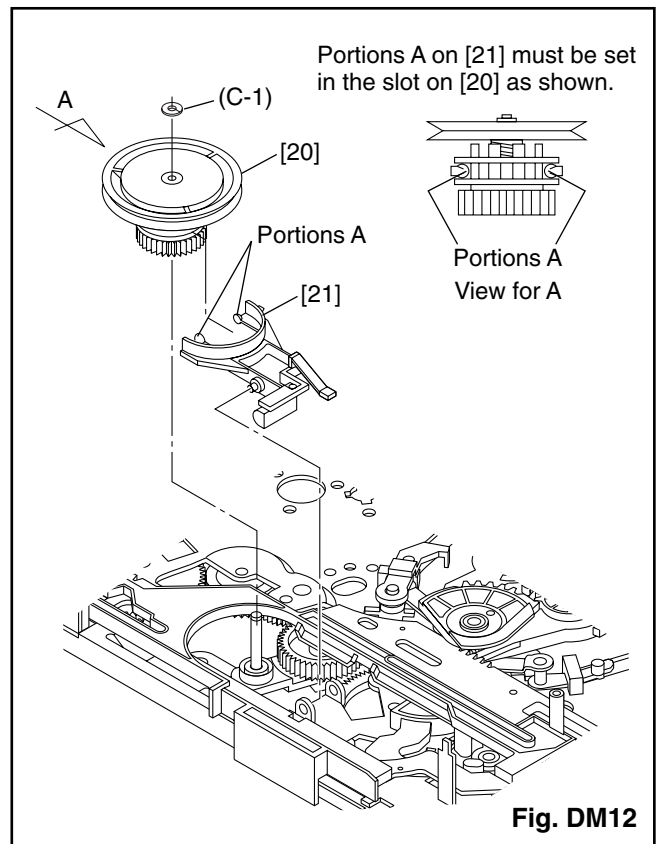
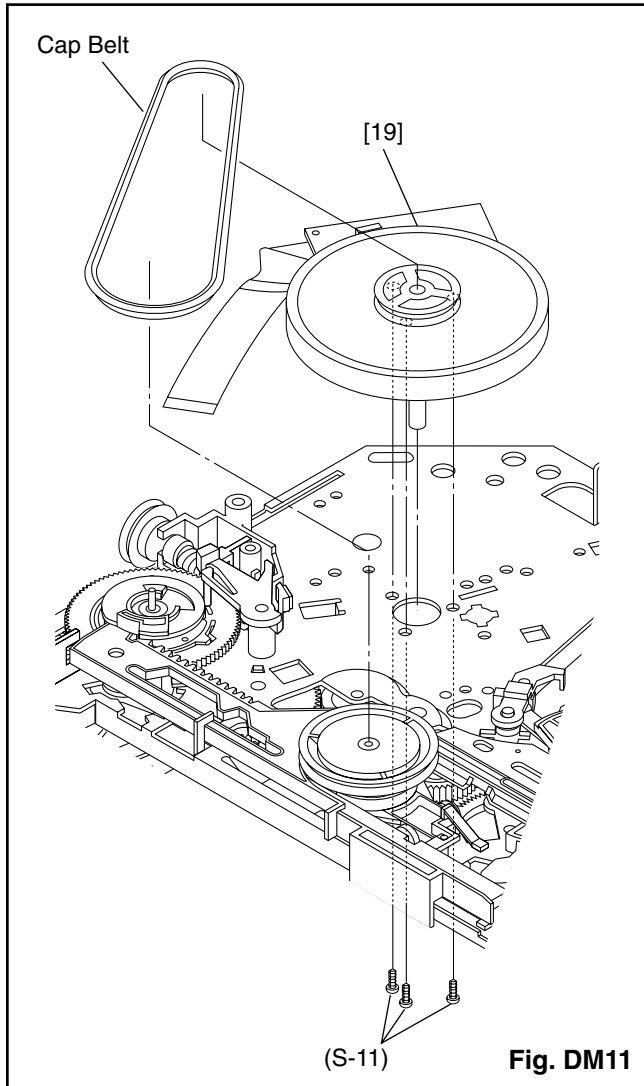

Fig. DM6





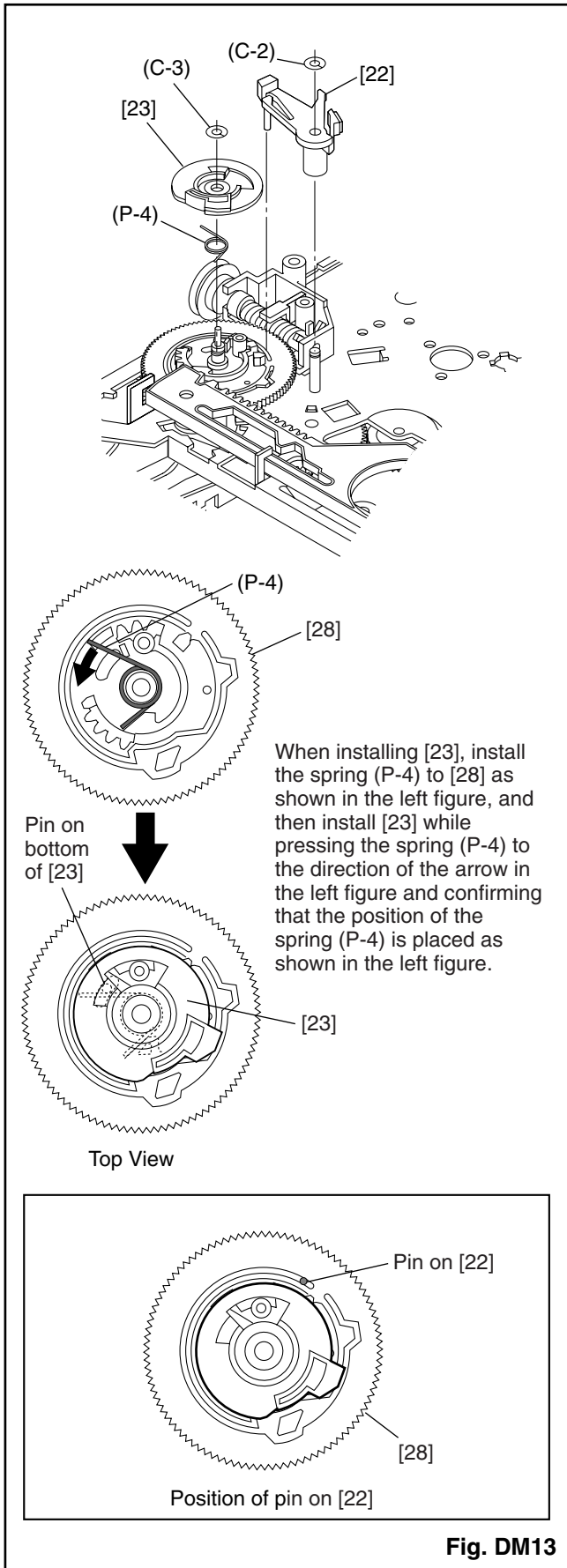

Fig. DM13

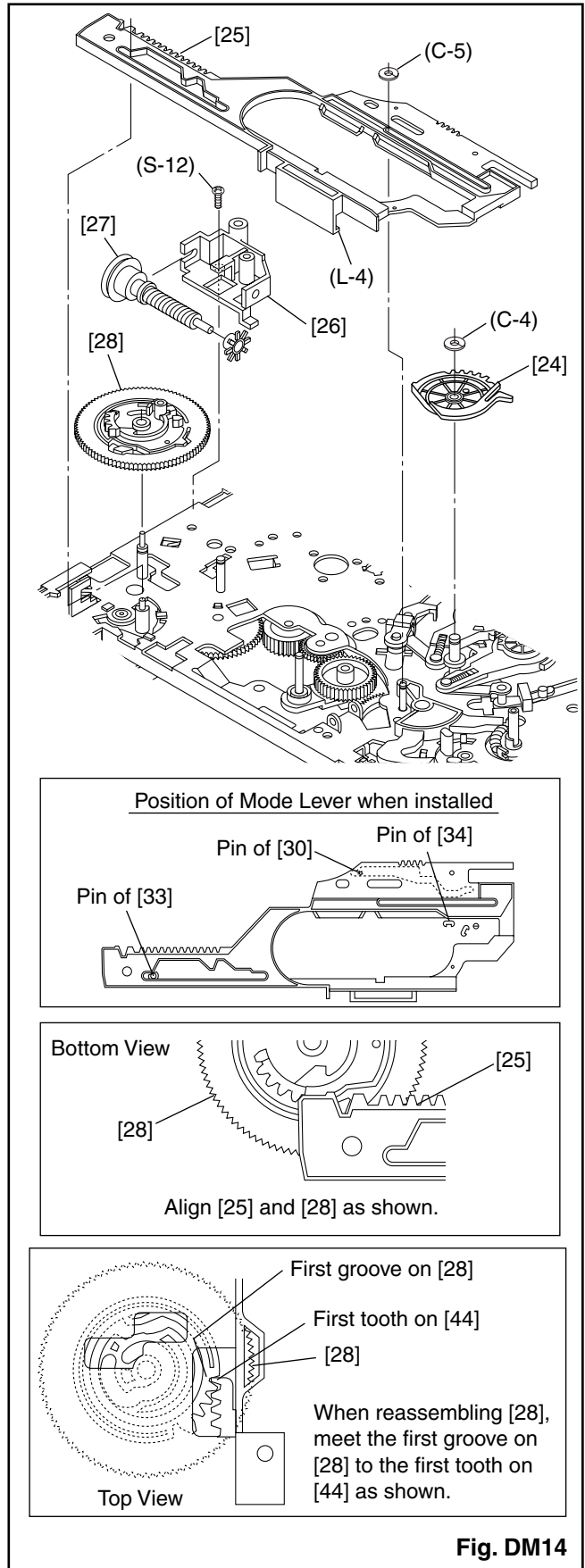
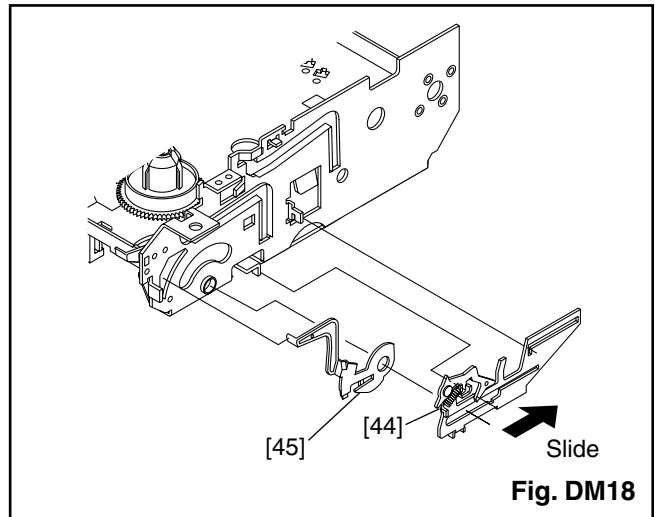
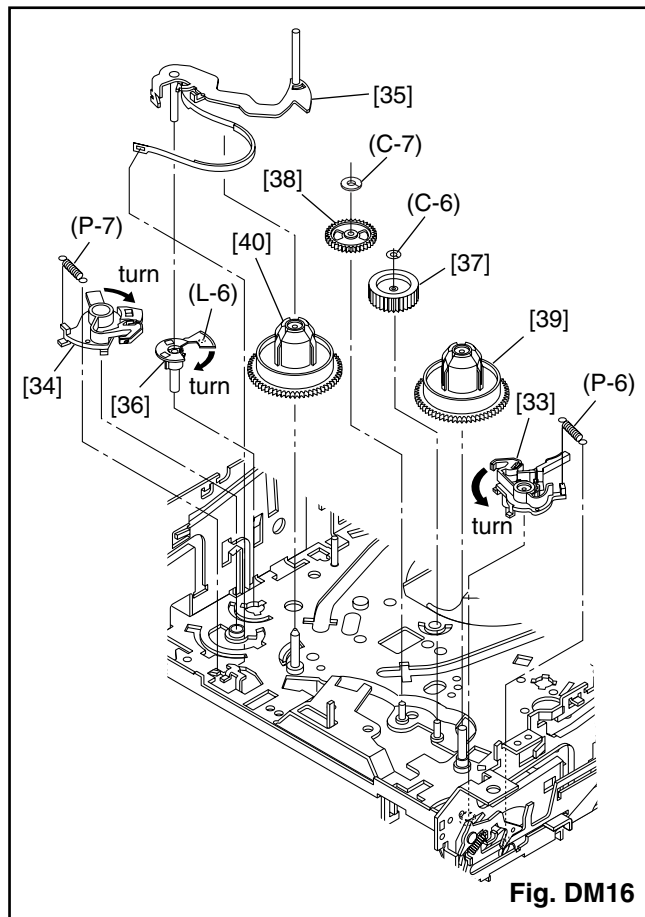
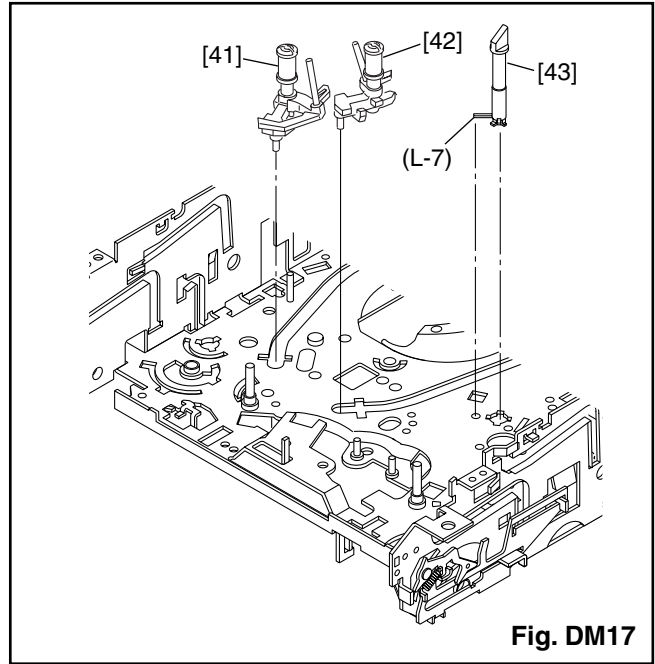
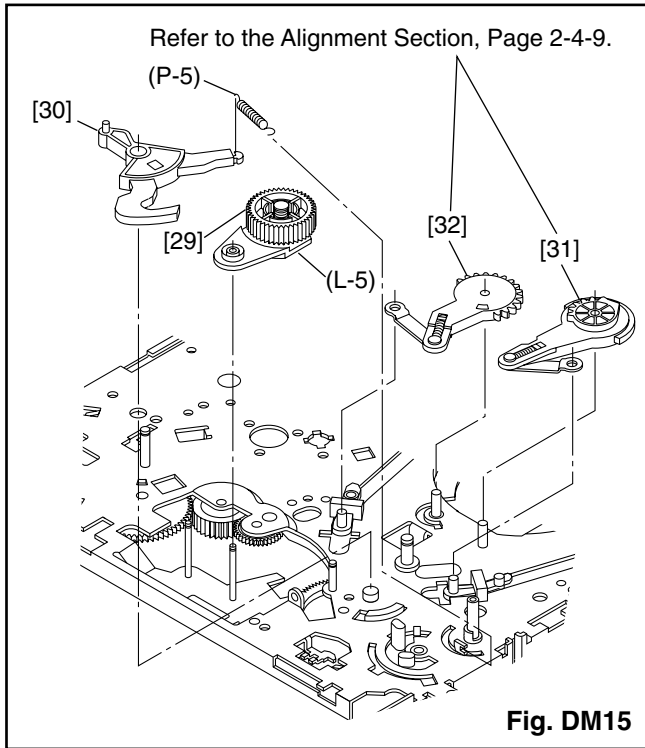

Fig. DM14



ALIGNMENT PROCEDURES OF MECHANISM

The following procedures describe how to align the individual gears and levers that make up the tape loading/unloading mechanism. Since information about the state of the mechanism is provided to the System Control Circuit only through the Mode Switch, it is essential that the correct relationship between individual gears and levers be maintained.

All alignments are to be performed with the mechanism in Eject mode, in the sequence given. Each procedure assumes that all previous procedures have been completed.

IMPORTANT:

If any one of these alignments is not performed properly, even if off by only one tooth, the unit will unload or stop and it may result in damage to the mechanical or electrical parts.

Alignment points in Eject Position

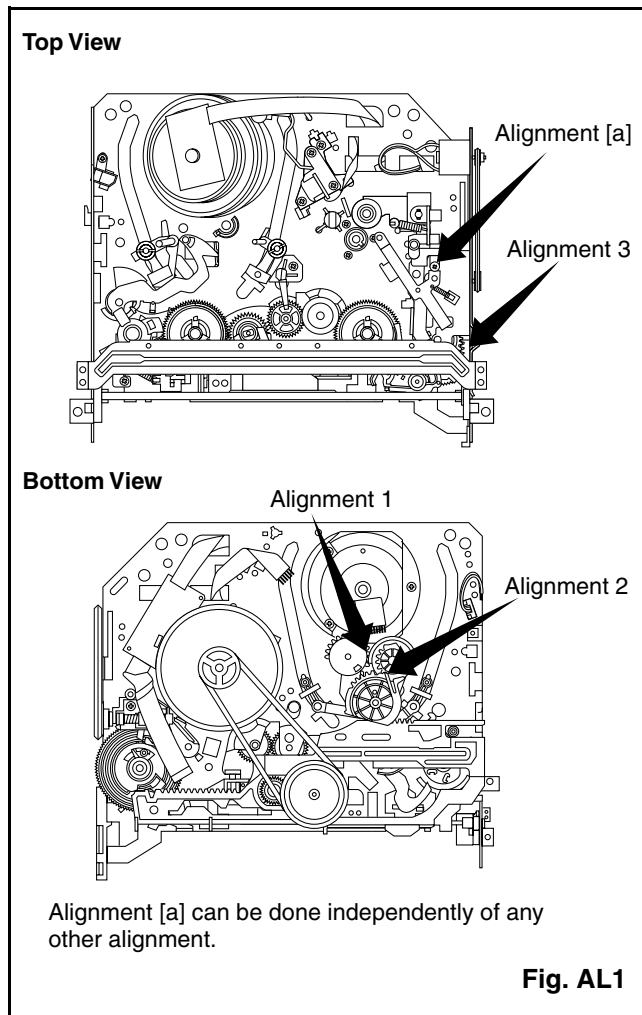

Alignment 1

Loading Arm, S and T Assembly

Install Loading Arm S and T Assembly so that their triangle marks point to each other as shown in Fig. AL2.

Alignment 2

Mode Gear

Keeping the two triangles pointing at each other, install the Loading Arm T Assembly so that the last tooth of the gear meets the most inside teeth of the Mode Gear. See Fig. AL2.

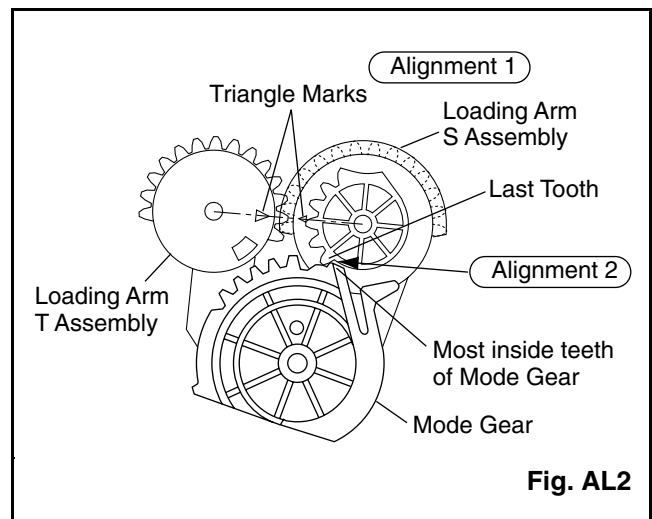

Alignment [a]

Tape Guide Assembly

Measurement of the screw must be as specified in Fig. AL3.

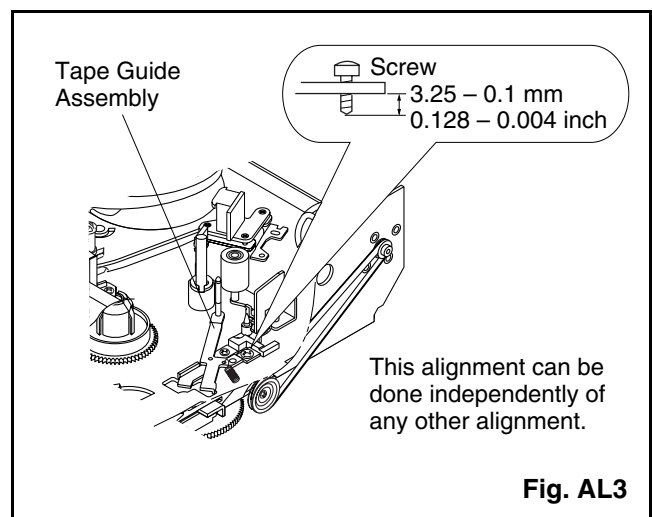

Alignment 3

Cam Gear (A), Rack Assembly

Install the Rack Assembly so that the first tooth on the gear of the Rack Assembly meets the first groove on the Cam Gear (A) as shown in Fig. AL4.

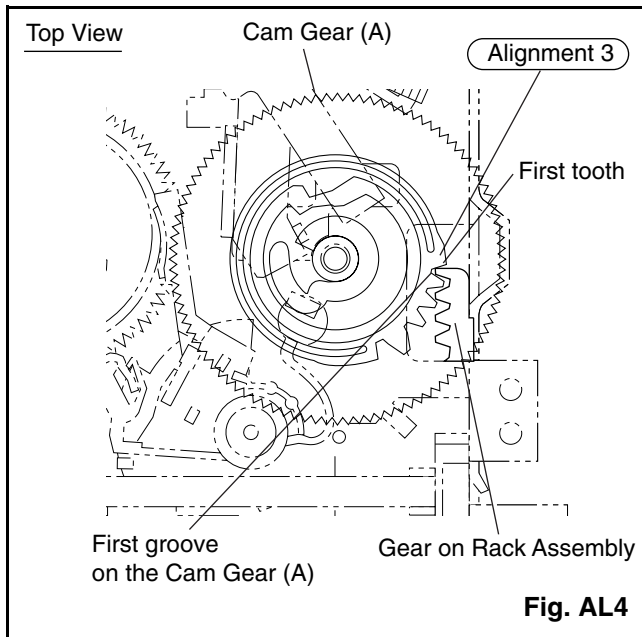

EXPLODED VIEWS AND PARTS LIST SECTION

13" COLOR TV/VCR COMBINATION

SSC132

**Sec. 3: Exploded views
and Parts List Section**
● Exploded views
● Parts List

TABLE OF CONTENTS

Cabinet Exploded Views	3-1-1
Packing Exploded Views	3-1-3
Deck Exploded Views	3-1-4
Mechanical Parts List	3-2-1
Electrical Parts List	3-3-1
Deck Parts List	3-4-1

Cabinet

EXPLODED VIEWS

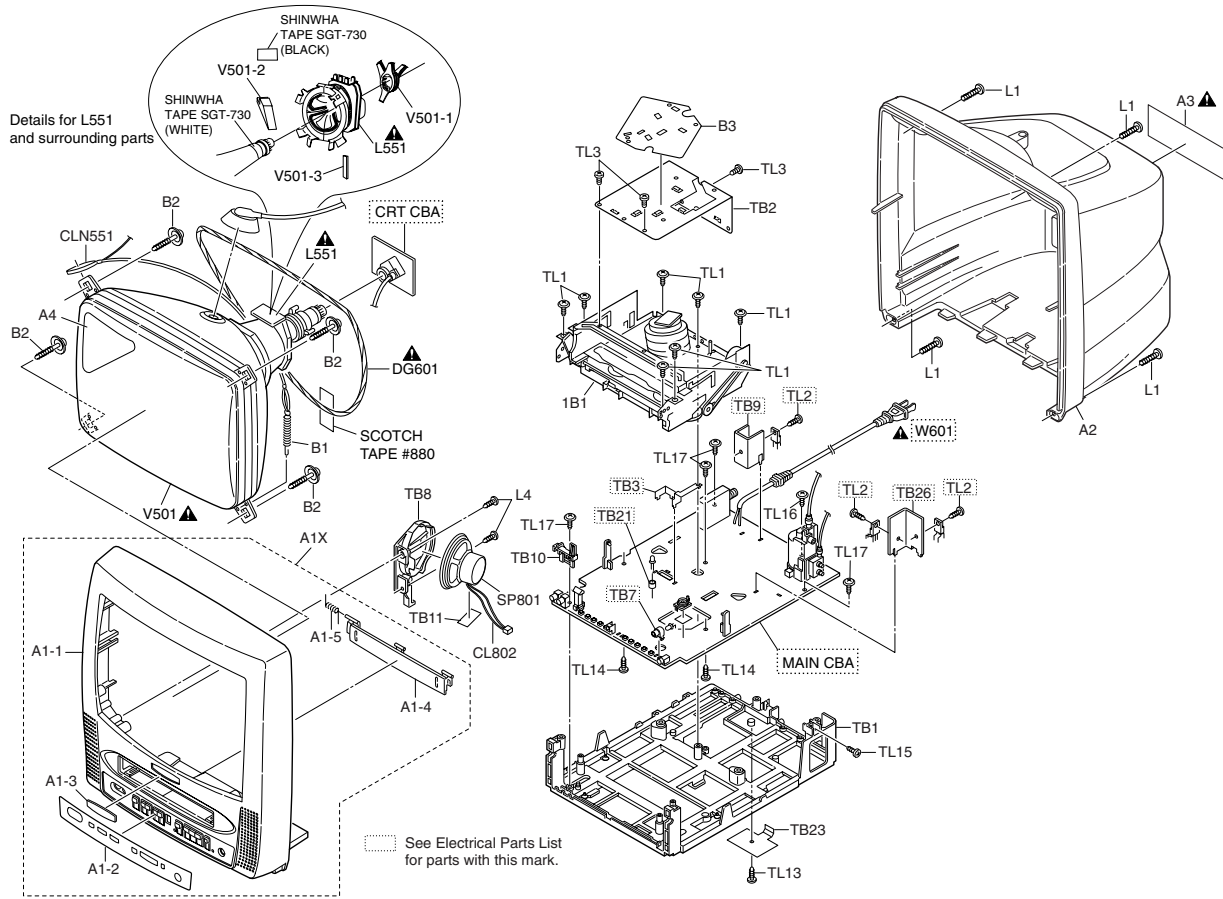

3-1-1

3-1-2

T5304CEX

See Electrical Parts List for parts with this mark.

Packing

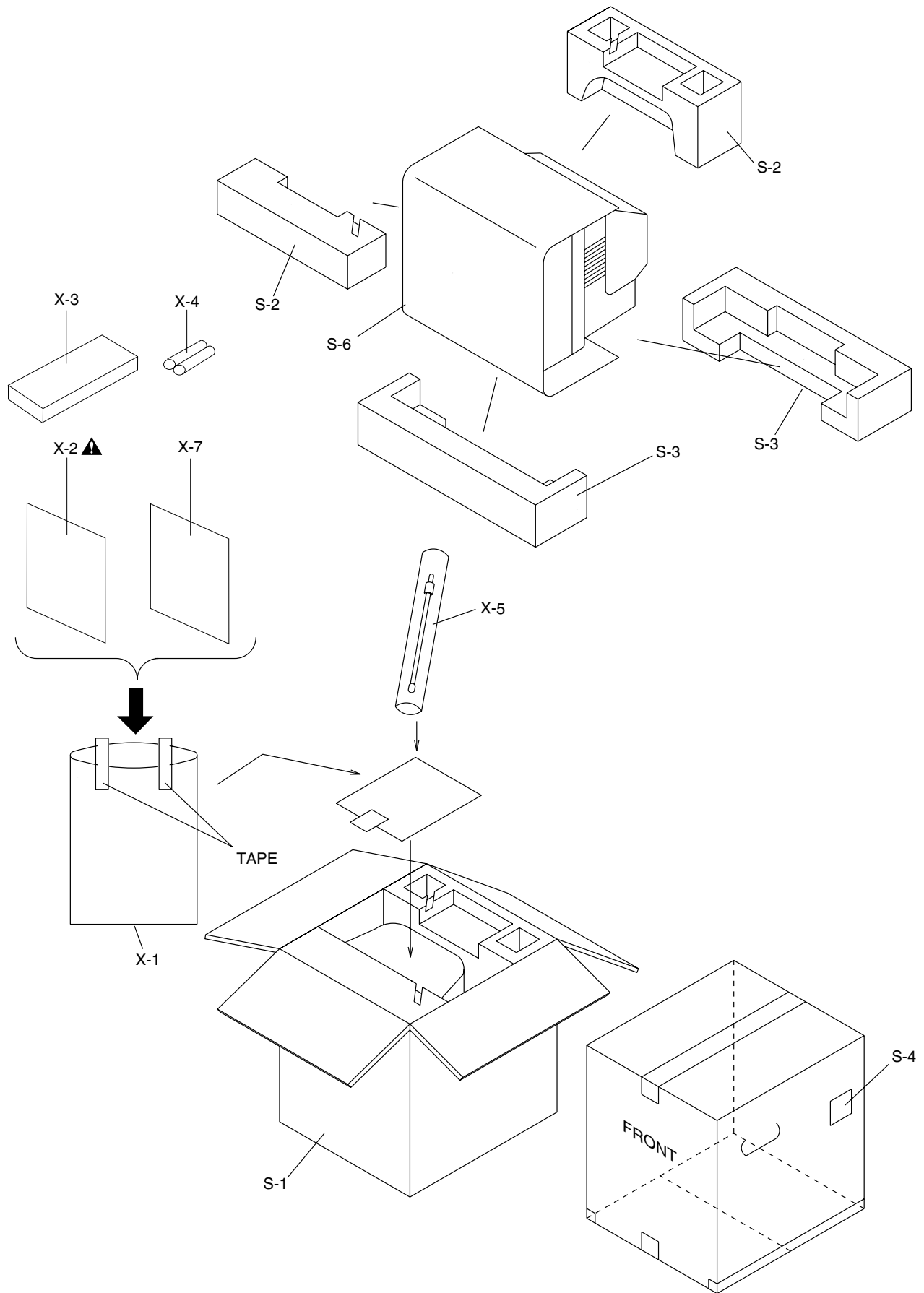

DECK EXPLODED VIEWS

Deck Mechanism View 1

Mark	Description	Part No.
•••••	Floil G-374G (Blue grease)	0VZZ00109
▲▲▲▲▲	SLIDUS OIL #150	0VZZ00226

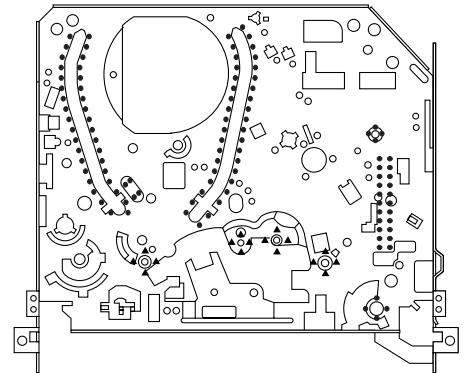
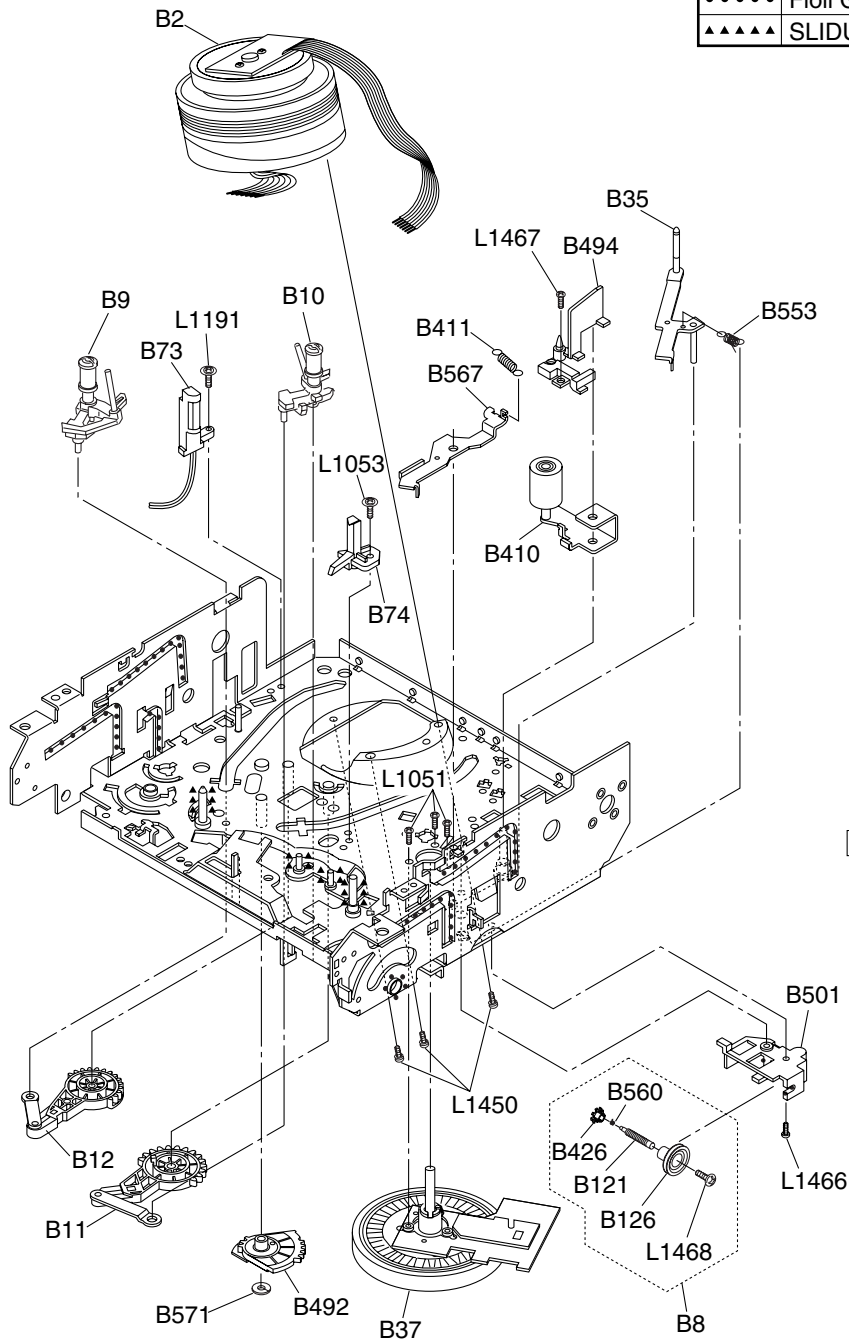

Chassis Assembly
Top View (Lubricating Point)

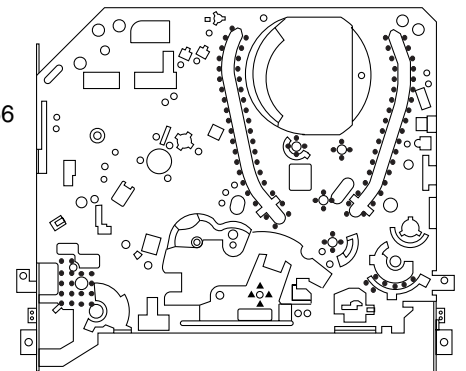

Chassis Assembly
Bottom View (Lubricating Point)

Some Ref. Numbers are not in sequence.

Deck Mechanism View 2

Mark	Description	Part No.
•••••	Floil G-374G (Blue grease)	0VZZ00109

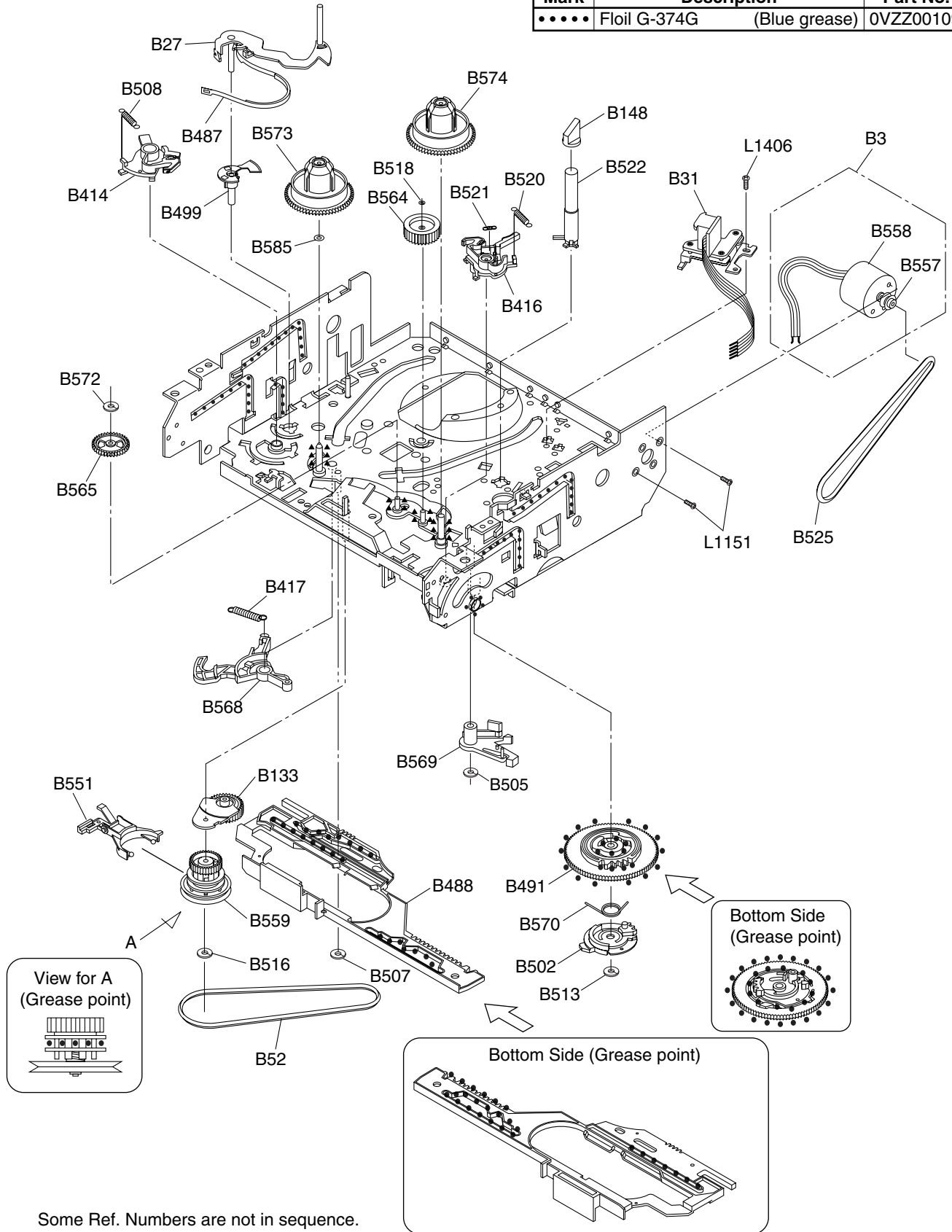

Some Ref. Numbers are not in sequence.

Deck Mechanism View 3

Mark	Description	Part No.
•••••	Floil G-374G (Blue grease)	0VZZ00109

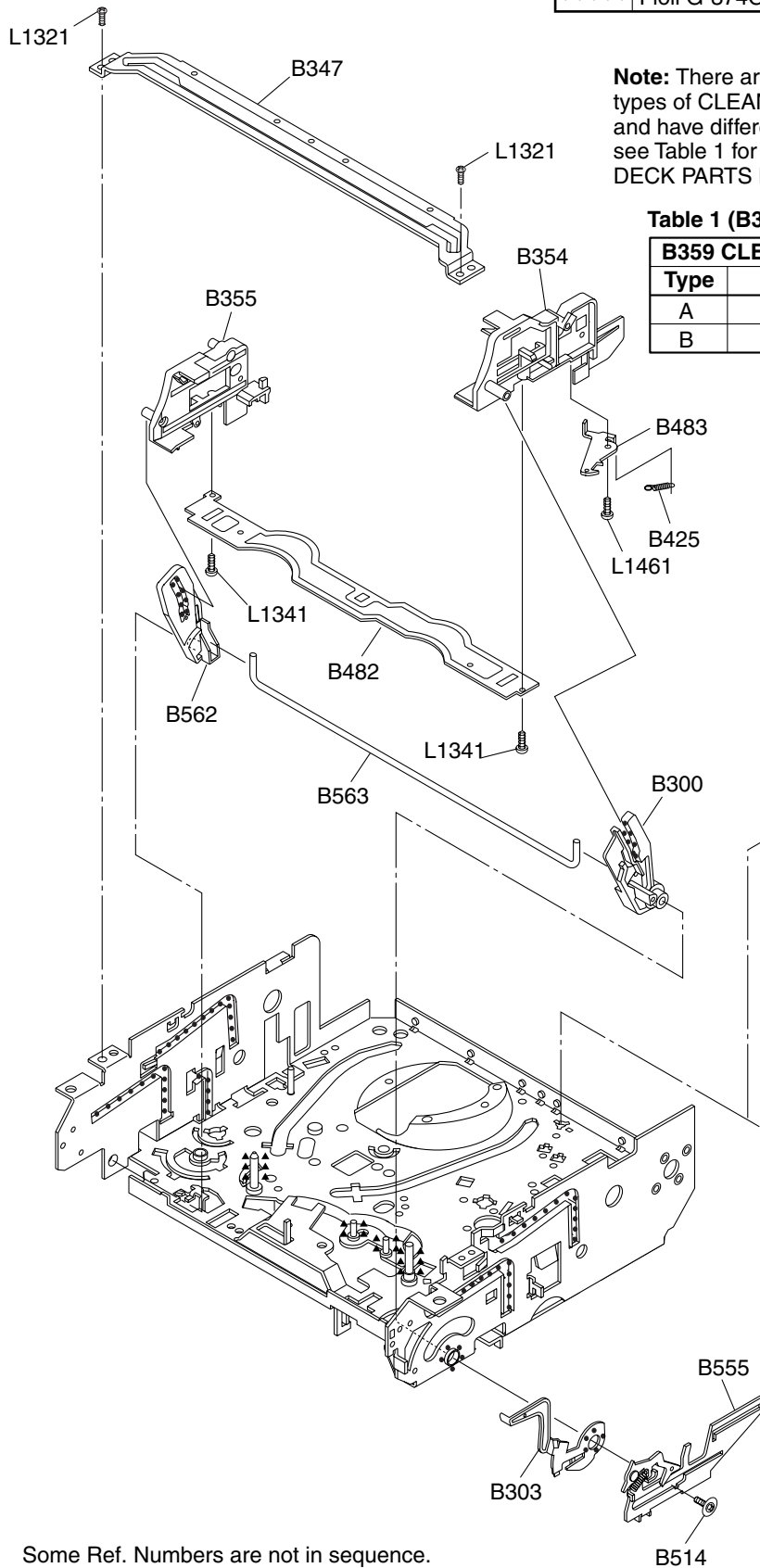

Note: There are two different, but interchangeable types of CLEANER LEVER(B359) in this model, and have different combination with B361. Please see Table 1 for details and combination. (Refer to DECK PARTS LIST section on page 3-4-1.)

Table 1 (B359 and B361 Combination)

B359 CLEANER LEVER		B361
Type	ID No.	ID No.
A	OVM304413	OVM411114
B	OVM305090	Not used

Some Ref. Numbers are not in sequence.

MECHANICAL PARTS LIST

PRODUCT SAFETY NOTE: Products marked with a **▲** have special characteristics important to safety. Before replacing any of these components, read carefully the product safety notice in this service manual. Don't degrade the safety of the product through improper servicing.

NOTE:

Parts that are not assigned part numbers (-----) are not available.

Ref. No.	Description	Part No.
A1X	FRONT CABINET ASSEMBLY T5304UE	0EM101167
A1-1	FRONT CABINET T5304UE	0EM000615
A1-2	CONTROL PLATE T5304UE	0EM201575
A1-3	BRAND PLATE T5307UH:SYLVANIA	0EM407053
A1-4	CASSETTE DOOR T5304UE	0EM407019
A1-5	DOOR SPRING B5000UA or DOOR SPRING(Z10) T5200UA	0VM403773 0EM406687
A2	REAR CABINET T5303UD	0EM000604
A3▲	RATING LABEL T5304UE	-----
A4	POP LABEL T5304UE	0EM407025
1B1	DECK ASSEMBLY CZD011/VM1446	N1446FT
B1	TENSION SPRING B0080B0:EM40808	26WH006
B2	M5 CRT SCREW(B) B4000UA	0VM403923
B3	SHIELD PLATE (Z11 13V) T5300UA	0EM406843
CL802	WIRE ASSEMBLY 2P/150	WX1B5900-001
CLN551	CRT GND WIRE CRT GND	WX1L7720-001
DG601▲	DEGAUSSING COIL F-019 or ▲ DEGAUSSING COIL AVDG016	LLBH00ZTM019 LLBH00ZWR016
L1	SCREW, P-TIGHT 4X18 BIND HEAD +	GBMP4180
L4	SCREW, P-TIGHT 3X10 BIND HEAD	GBUP3100
SP801	SPEAKER S08F02B or SPEAKER J-F097-C5	DSD0808XQ010 DSD0808DCP01
TB1	TRAY CHASSIS T5300UA	0EM000588
TB2	TOP SHIELD T5300UA	0EM301573
TB8	SPEAKER HOLDER T5100UA	0EM201157B
TB10	RCA HOLDER T5300UA	0EM406869
TB11	CLOTH(10X30X0.5) B5900UA	0EM404486
TB23	TRAY COVER TD250UA	0EM406459
TL1	SCREW, P-TIGHT 3X12 WASHER HEAD+	GCMP3120
TL3	SCREW, S-TIGHT 3X4 BIND HEAD+	GBMS3040
TL13	SCREW, B-TIGHT M3X8 BIND HEAD+	GBMB3080
TL14	SCREW, B-TIGHT M3X8 BIND HEAD+	GBMB3080
TL15	SCREW TAPPING M4X14	DBU14140
TL16	SCREW, P-TIGHT 3X10 BIND HEAD+	GBMP3100
TL17	SCREW, P-TIGHT M3X10 WASHER HEAD+	GCMP3100
PACKING		
S1	CARTON T5304UE	0EM407048
S2	STYROFOAM TOP ASSEMBLY T5300UA	0EM406844
S3	STYROFOAM BOTTOM ASSEMBLY T5300UA	0EM406845
S4	SERIAL NO. LABEL T5304UE	0EM407049
S6	SET SHEET B5506UG:800X1500	0EM402369
ACCESSORIES		
X1	POLYETHYLENE BAG B5310UL	Z223380
X2▲	OWNER'S MANUAL T5304UE	0EMN01900
X3	REMOCON UNIT 512/ERC001/N0148UD	N0148UD

Ref. No.	Description	Part No.
X4	DRY BATTERY R6P UM3 or DRY BATTERY R6P(AR)2PX or DRY BATTERY R6P(AR)2P X ICI or DRY BATTERY(SUNRISE) R6SSE/2S or DRY BATTERY R6P/2S	XB0M451GH001 XB0M451HU002 XB0M451HU003 XB0M451MS002 XB0M451T0001
X5	ROD ANTENNA T5200UA or ROD ANTENNA L7720UA:NTSC W/COO or ROD ANTENNA T5000UA	0EMN01755 0EMN00673 0EMN01599
X7	RETURN STOP SHEET L6101UB	0EM407077
Note: 1. V501 (CRT) HAS COUPLE OF SUBSTITUTIONAL PARTS AND EACH PARTS ALSO HAS MATCHING COMBINATION WITH L551. PLEASE SEE TABLE 1 FOR DETAILS OF MATCHING COMBINATION. 2. L551 (DEFLECTION YOKE) HAS MATCHING COMBINATION WITH V501. PLEASE SEE TABLE 1 FOR DETAILS OF MATCHING COMBINATION.		
CRT TYPE A		
L551▲	DEFLECTION YOKE LLBY00ZSY005	LLBY00ZSY005
V501▲	CRT A34AGT13X	TCRT190CP036
V501-1	C.P.MAGNET JH225-FN-00	XM04000BV003
V501-2	WEDGE FT-00110W or WEDGE DB25SR	XV10000T4001 XV10000D9001
V501-3	RUBBER MAGNET 20X10X1.2	XM05000BV001
CRT TYPE B		
L551▲	DEFLECTION YOKE KDY3GDA82X	LLBY00ZMS011
V501▲	CRT A34AGT13X	TCRT190CP036
V501-1	C.P.MAGNET JH225-FN-00	XM04000BV003
V501-2	WEDGE FT-00110W or WEDGE DB25SR	XV10000T4001 XV10000D9001
V501-3	RUBBER MAGNET 20X10X1.2	XM05000BV001
CRT TYPE C		
L551▲	DEFLECTION YOKE LLBY00ZSY002	LLBY00ZSY002
V501▲	CRT A34KQW42X	TCRT190SM013
V501-1	C.P.MAGNET JH225-FN-00	XM04000BV003
V501-2	WEDGE FT-00110W or WEDGE DB25SR	XV10000T4001 XV10000D9001
V501-3	RUBBER MAGNET 20X10X1.2	XM05000BV001
CRT TYPE D		
L551▲	DEFLECTION YOKE CDY-M1456S	LLBY00ZQS008
V501▲	CRT A34KQW42X	TCRT190SM013
V501-1	C.P.MAGNET JH225-FN-00	XM04000BV003
V501-2	WEDGE FT-00110W or WEDGE DB25SR	XV10000T4001 XV10000D9001
V501-3	RUBBER MAGNET 20X10X1.2	XM05000BV001
CRT TYPE E		
L551▲	DEFLECTION YOKE CDY-M1422F	LLBY00ZQS001
V501▲	CRT A34JLL90X(W)	TCRT190QS015
V501-1	C.P.MAGNET JH225-FN-00	XM04000BV003
V501-2	WEDGE FT-00110W or WEDGE DB25SR	XV10000T4001 XV10000D9001
V501-3	RUBBER MAGNET 20X10X1.2	XM05000BV001
CRT TYPE F		
L551▲	DEFLECTION YOKE CDY-M1455F	LLBY00ZQS007
V501▲	CRT A34LRQ90X(VW)	TCRT190P7003
V501-1	C.P.MAGNET JH225-FN-00	XM04000BV003
V501-2	WEDGE FT-00110W or WEDGE DB25SR	XV10000T4001 XV10000D9001
V501-3	RUBBER MAGNET 20X10X1.2	XM05000BV001
CRT TYPE G		

Ref. No.	Description	Part No.
L 551▲	DEFLECTION YOKE LLBY00ZSY002	LLBY00ZSY002
V 501▲	CRT A34KPU02XX	TCRT190GS016
V501-1	C.P.MAGNET JH225-FN-00	XM04000BV003
V501-2	WEDGE FT-00110W or WEDGE DB25SR	XV10000T4001 XV10000D9001
V501-3	RUBBER MAGNET 20X10X1.2	XM05000BV001
CRT TYPE H		
L551▲	DEFLECTION YOKE ST14PWR01	LLBY00ZSAM01
V501▲	CRT A34LEX10X	TCRT190SAM01
V501-1	C.P.MAGNET JH225-FN-00	XM04000BV003
V501-2	WEDGE FT-00110W or WEDGE DB25SR	XV10000T4001 XV10000D9001
V501-3	RUBBER MAGNET 20X10X1.2	XM05000BV001
CRT TYPE I		
L551▲	DEFLECTION YOKE LLBY00ZSY002	LLBY00ZSY002
V501▲	CRT A34JQQ093X	TCRT190MS010
V501-1	C.P.MAGNET JH225-FN-00	XM04000BV003
V501-2	WEDGE FT-00110W or WEDGE DB25SR	XV10000T4001 XV10000D9001
V501-3	RUBBER MAGNET 20X10X1.2	XM05000BV001
CRT TYPE J		
L551▲	DEFLECTION YOKE KDY3GCB82X	LLBY00ZMS018
V501▲	CRT A34JQQ093X	TCRT190MS010
V501-1	C.P.MAGNET JH225-FN-00	XM04000BV003
V501-2	WEDGE FT-00110W or WEDGE DB25SR	XV10000T4001 XV10000D9001
V501-3	RUBBER MAGNET 20X10X1.2	XM05000BV001
CRT TYPE K		
L551▲	DEFLECTION YOKE KDY3GC734X	LLBY00ZMS006
V501▲	CRT A34KQW42X	TCRT190SM013
V501-1	C.P.MAGNET JH225-FN-00	XM04000BV003
V501-2	WEDGE FT-00110W or WEDGE DB25SR	XV10000T4001 XV10000D9001
V501-3	RUBBER MAGNET 20X10X1.2	XM05000BV001

Table 1 (V501 and L551 Combination)

Note 1: Purity and Convergence Adjustments must be performed following CRT replacement. Refer to Electrical Adjustment Instructions.

Note 2: Please confirm CRT Type No. on the CRT Warning Label which is located on the CRT. Then See the Table 1 for V501 and L551 combination chart.

Please refer this CRT, Deflection Yoke combination chart for parts order.

V501: CRT Type No.	V501: CRT Part No.	L551: Deflection Yoke Part No.
CRT A34AGT13X	TCRT190CP036	LLBY00ZSY005
CRT A34AGT13X	TCRT190CP036	LLBY00ZMS011
CRT A34KQW42X	TCRT190SM013	LLBY00ZSY002
CRT A34KQW42X	TCRT190SM013	LLBY00ZQS008
CRT A34JLL90X(W)	TCRT190QS015	LLBY00ZQS001
CRT A34LRQ90X(VW)	TCRT190P7003	LLBY00ZQS007
CRT A34KPU02XX	TCRT190GS016	LLBY00ZSY002
CRT A34LEX10X	TCRT190SAM01	LLBY00ZSAM01
CRT A34JQQ093X	TCRT190MS010	LLBY00ZSY002
CRT A34JQQ093X	TCRT190MS010	LLBY00ZMS018
CRT A34KQW42X	TCRT190SM013	LLBY00ZMS006

CRT Warning Label Location

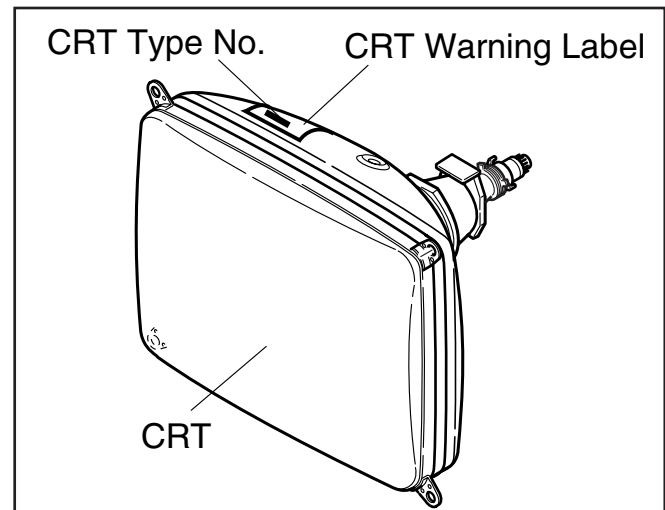

ELECTRICAL PARTS LIST

PRODUCT SAFETY NOTE: Products marked with a  have special characteristics important to safety. Before replacing any of these components, read carefully the product safety notice in this service manual. Don't degrade the safety of the product through improper servicing.

NOTES:

- Parts that are not assigned part numbers (-----) are not available.
- Tolerance of Capacitors and Resistors are noted with the following symbols.

C.....±0.25% D.....±0.5% F.....±1%
 G.....±2% J.....±5% K.....±10%
 M.....±20% N.....±30% Z.....+80/-20%

MMA CBA

Ref. No.	Description	Part No.
	MMA CBA (MAIN+CRT+SENSOR) Consists of the followings	0ESA04665
	MAIN CBA (MMA-A) CRT CBA (MMA-B) SENSOR CBA	----- ----- 0ESA04524

MAIN CBA

Ref. No.	Description	Part No.
	MAIN CBA (MMA-A) Consists of the followings	-----
CAPACITORS		
C001	CERAMIC CAP.(AX) Y M 0.01µF/16V	CCA1CMT0Y103
C002	CHIP CERAMIC CAP. CH J 100pF/50V	CHD1JJBCH101
C003	CHIP CERAMIC CAP. CH J 100pF/50V	CHD1JJBCH101
C004	CHIP CERAMIC CAP.(MELF) F Z 0.01µF/16V	CZM1CZB0F103
C005	ELECTROLYTIC CAP. 47µF/6.3V M H7	CE0KMAVSL470
C006	ELECTROLYTIC CAP. 1µF/50V M H7	CE1JMAVSL1R0
C007	CHIP CERAMIC CAP. B K 0.01µF/50V	CHD1JKB0B103
C205	CERAMIC CAP.(AX) Y M 0.01µF/16V	CCA1CMT0Y103
C207	ELECTROLYTIC CAP. 47µF/6.3V M H7	CE0KMAVSL470
C208	ELECTROLYTIC CAP. 47µF/6.3V M H7	CE0KMAVSL470
C209	CHIP CERAMIC CAP. B K 0.022µF/50V or CHIP CERAMIC CAP. B K 0.022µF/25V	CHD1JKB0B223 CHD1EKB0B223
C210	ELECTROLYTIC CAP. 1µF/50V M H7	CE1JMAVSL1R0
C212	CHIP CERAMIC CAP.(MELF) SL J 22pF/50V	CZM1JJBLSL220
C213	CHIP CERAMIC CAP.(MELF) SL J 22pF/50V	CZM1JJBLSL220
C214	ELECTROLYTIC CAP. 100µF/6.3V H7	CE0KMAVSL101
C216	CHIP CERAMIC CAP.(MELF) F Z 0.01µF/16V	CZM1CZB0F103
C217	CHIP CERAMIC CAP.(MELF) SL D 10pF/50V	CZM1JDBSL100
C218	CHIP CERAMIC CAP.(MELF) SL J 15pF/50V	CZM1JJBLSL150
C220	ELECTROLYTIC CAP. 47µF/6.3V M H7	CE0KMAVSL470
C221	CHIP CERAMIC CAP.(MELF) F Z 0.01µF/16V	CZM1CZB0F103
C222	CHIP CERAMIC CAP.(MELF) Y K 2200pF/35V	CZM1GKB0Y222
C223	ELECTROLYTIC CAP. 1µF/50V M H7	CE1JMAVSL1R0
C224	CHIP CERAMIC CAP.(MELF) Y K 1000pF/35V	CZM1GKB0Y102
C225	CHIP CERAMIC CAP.(MELF) W K 560pF/50V	CZM1JKB0B561
C231	CHIP CERAMIC CAP. CH J 100pF/50V	CHD1JJBCH101

Ref. No.	Description	Part No.
C232	CHIP CERAMIC CAP. CH J 100pF/50V	CHD1JJBCH101
C235	CERAMIC CAP.(AX) Y M 0.01µF/16V	CCA1CMT0Y103
C236	CERAMIC CAP.(AX) F Z 0.047µF/16V	CCA1CZTFZ473
C238	CHIP CERAMIC CAP.(MELF) Y K 1000pF/35V	CZM1GKB0Y102
C239	ELECTROLYTIC CAP. 22µF/50V M or ELECTROLYTIC CAP. 22µF/50V M	CE1JMASDL220 CE1JMASTL220
C240	CHIP CERAMIC CAP.(MELF) W K 560pF/50V	CZM1JKB0B561
C241	CHIP CERAMIC CAP.(MELF) Y K 4700pF/16V	CZM1CZB0Y472
C242	CHIP CERAMIC CAP.(MELF) Y K 1000pF/35V	CZM1GKB0Y102
C243	ELECTROLYTIC CAP. 22µF/16V M LL or ELECTROLYTIC CAP. 22µF/16V M LL	CE1CMASLL220 CE1CMASLH220
C244	CHIP CERAMIC CAP.(MELF) F Z 0.01µF/16V	CZM1CZB0F103
C245	ELECTROLYTIC CAP. 47µF/25V M or ELECTROLYTIC CAP. 47µF/25V M	CE1EMASDL470 CE1EMASTL470
C246	CHIP CERAMIC CAP.(MELF) F Z 0.01µF/16V	CZM1CZB0F103
C247	ELECTROLYTIC CAP. 22µF/50V M or ELECTROLYTIC CAP. 22µF/50V M	CE1JMASDL220 CE1JMASTL220
C251	CHIP CERAMIC CAP. F Z 0.1µF/50V or CHIP CERAMIC CAP. F Z 0.1µF/25V	CHD1JZB0F104 CHD1EZB0F104
C252	ELECTROLYTIC CAP. 220µF/16V M or ELECTROLYTIC CAP. 220µF/16V M	CE1CMASDL221 CE1CMASL221
C253	CERAMIC CAP.(AX) B K 100pF/50V	CCA1JKT0B101
C255	ELECTROLYTIC CAP. 100µF/10V M or ELECTROLYTIC CAP. 100µF/10V M	CE1AMASDL101 CE1AMASTL101
C257	CHIP CERAMIC CAP.(MELF) Y K 1000pF/35V	CZM1GKB0Y102
C301	ELECTROLYTIC CAP. 1µF/50V M LL or ELECTROLYTIC CAP. 1µF/50V LL	CE1JMASLL010 CE1JMASLH1R0
C302	CHIP CERAMIC CAP. B K 0.01µF/50V	CHD1JKB0B103
C304	ELECTROLYTIC CAP. 220µF/16V M or ELECTROLYTIC CAP. 220µF/16V M	CE1CMASDL221 CE1CMASL221
C305	CHIP CERAMIC CAP. B K 0.01µF/50V	CHD1JKB0B103
C306	ELECTROLYTIC CAP. 1µF/50V M or ELECTROLYTIC CAP. 1µF/50V M	CE1JMASDL1R0 CE1JMASTL1R0
C307	ELECTROLYTIC CAP. 100µF/10V M or ELECTROLYTIC CAP. 100µF/10V M	CE1AMASDL101 CE1AMASTL101
C308	CHIP CERAMIC CAP. CH J 47pF/50V	CHD1JJBCH470
C309	CHIP CERAMIC CAP. CH J 47pF/50V	CHD1JJBCH470
C310	CHIP CERAMIC CAP. CH J 47pF/50V	CHD1JJBCH470
C311	CHIP CERAMIC CAP. B K 0.01µF/50V	CHD1JKB0B103
C314	ELECTROLYTIC CAP. 1µF/50V M or ELECTROLYTIC CAP. 1µF/50V M	CE1JMASDL1R0 CE1JMASTL1R0
C317	CHIP CERAMIC CAP. B K 0.022µF/50V or CHIP CERAMIC CAP. B K 0.022µF/25V	CHD1JKB0B223 CHD1EKB0B223
C318	ELECTROLYTIC CAP. 1µF/50V M or ELECTROLYTIC CAP. 1µF/50V M	CE1JMASDL1R0 CE1JMASDL010
C319	ELECTROLYTIC CAP. 1µF/50V M or ELECTROLYTIC CAP. 1µF/50V M	CE1JMASTL1R0 CE1JMASDL010
C320	ELECTROLYTIC CAP. 100µF/10V M or ELECTROLYTIC CAP. 100µF/10V M	CE1AMASDL101 CE1AMASTL101
C322	ELECTROLYTIC CAP. 1µF/50V M or ELECTROLYTIC CAP. 1µF/50V M	CE1JMASDL1R0 CE1JMASDL010
C323	ELECTROLYTIC CAP. 470µF/10V M or	CE1AMASDL471

Ref. No.	Description	Part No.
	ELECTROLYTIC CAP. 470µF/10V M	CE1AMASTL471
C325	ELECTROLYTIC CAP. 2.2µF/50V M LL or	CE1JMASLL2R2
	ELECTROLYTIC CAP. 2.2µF/50V LL	CE1JMASLH2R2
C326	FILM CAP.(P) 0.1µF/50V J or	CMA1JJS00104
	FILM CAP.(P) 0.1µF/50V J	CA1J104MS029
C328	CERAMIC CAP.(AX) X M 3300pF/16V	CCA1CMT0X332
C329	ELECTROLYTIC CAP. 4.7µF/50V M or	CE1JMASDL4R7
	ELECTROLYTIC CAP. 4.7µF/50V M	CE1JMASTL4R7
C330	ELECTROLYTIC CAP. 0.47µF/50V M or	CE1JMASDLR47
	ELECTROLYTIC CAP. 0.47µF/50V M	CE1JMASTLR47
C331	CHIP CERAMIC CAP. CH J 680pF/50V	CHD1JJBCH681
C332	CHIP CERAMIC CAP. B K 0.047µF/50V or	CHD1JKB0B473
	CHIP CERAMIC CAP. B K 0.047µF/25V	CHD1EKB0B473
C333	FILM CAP.(P) 0.047µF/50V J or	CMA1JJS00473
	FILM CAP.(P) 0.047µF/50V J	CA1J473MS029
C335	ELECTROLYTIC CAP. 1µF/50V M H7	CE1JMAVSL1R0
C337	ELECTROLYTIC CAP. 100µF/16V M or	CE1CMASDL101
	ELECTROLYTIC CAP. 100µF/16V M	CE1CMASTL101
C343	ELECTROLYTIC CAP. 1µF/50V M or	CE1JMASDL1R0
	ELECTROLYTIC CAP. 1µF/50V M or	CE1JMASDL010
	ELECTROLYTIC CAP. 1µF/50V M	CE1JMASTL1R0
C345	CHIP CERAMIC CAP. CH J 47pF/50V	CHD1JJBCH470
C346	CHIP CERAMIC CAP. CH J 47pF/50V	CHD1JJBCH470
C410	ELECTROLYTIC CAP. 1µF/50V M H7	CE1JMAVSL1R0
C411	ELECTROLYTIC CAP. 100µF/6.3V H7	CE0KMAVSL101
C412	CHIP CERAMIC CAP.(MELF) F Z 0.01µF/16V	CZM1CZB0F103
C413	CHIP CERAMIC CAP.(MELF) W K 390pF/50V	CZM1JKB0B391
C414	ELECTROLYTIC CAP. 1µF/50V M H7	CE1JMAVSL1R0
C416	CHIP CERAMIC CAP.(MELF) B K 180pF/50V	CZM1JKB0B181
C417	CHIP CERAMIC CAP.(MELF) SL J 22pF/50V	CZM1JBSL220
C418	PCB JUMPER D0.6-P5.0	JW5.0T
C420	ELECTROLYTIC CAP. 22µF/16V M H7	CE1CMAVSL220
C421	ELECTROLYTIC CAP. 4.7µF/50V M H7	CE1JMAVSL4R7
C423	ELECTROLYTIC CAP. 4.7µF/50V M H7	CE1JMAVSL4R7
C424	ELECTROLYTIC CAP. 1µF/50V M H7	CE1JMAVSL1R0
C425	ELECTROLYTIC CAP. 1µF/50V M H7	CE1JMAVSL1R0
C426	ELECTROLYTIC CAP. 22µF/16V M H7	CE1CMAVSL220
C427	CERAMIC CAP.(AX) Y M 0.01µF/16V	CCA1CMT0Y103
C428	CHIP CERAMIC CAP.(MELF) F Z 0.01µF/16V	CZM1CZB0F103
C429	ELECTROLYTIC CAP. 47µF/6.3V M H7	CE0KMAVSL470
C430	CHIP CERAMIC CAP. B K 0.022µF/50V or	CHD1JKB0B223
	CHIP CERAMIC CAP. B K 0.022µF/25V	CHD1EKB0B223
C431	ELECTROLYTIC CAP. 1µF/50V M H7	CE1JMAVSL1R0
C433	CHIP CERAMIC CAP. CH J 270pF/50V	CHD1JJBCH271
C434	ELECTROLYTIC CAP. 1µF/50V M H7	CE1JMAVSL1R0
C435	ELECTROLYTIC CAP. 2.2µF/50V M H7	CE1JMAVSL2R2
C436	CHIP CERAMIC CAP.(MELF) Y K 4700pF/16V	CZM1CKB0Y472
C438	ELECTROLYTIC CAP. 1µF/50V M H7	CE1JMAVSL1R0
C439	CHIP CERAMIC CAP.(MELF) F Z 0.01µF/16V	CZM1CZB0F103
C440	ELECTROLYTIC CAP. 1µF/50V M H7	CE1JMAVSL1R0
C441	ELECTROLYTIC CAP. 1µF/50V M H7	CE1JMAVSL1R0
C442	CHIP CERAMIC CAP. B K 0.047µF/50V or	CHD1JKB0B473
	CHIP CERAMIC CAP. B K 0.047µF/25V	CHD1EKB0B473
C443	CHIP CERAMIC CAP. B K 0.047µF/50V or	CHD1JKB0B473
	CHIP CERAMIC CAP. B K 0.047µF/25V	CHD1EKB0B473
C444	ELECTROLYTIC CAP. 22µF/16V M H7	CE1CMAVSL220
C445	CHIP CERAMIC CAP.(MELF) F Z 0.01µF/16V	CZM1CZB0F103
C446	ELECTROLYTIC CAP. 1µF/50V M H7	CE1JMAVSL1R0
C447	CHIP CERAMIC CAP.(MELF) F Z 0.01µF/16V	CZM1CZB0F103
C448	CERAMIC CAP.(AX) Y M 0.01µF/16V	CCA1CMT0Y103
C449	CHIP CERAMIC CAP. F Z 0.1µF/50V or	CHD1JZB0F104

Ref. No.	Description	Part No.
	CHIP CERAMIC CAP. F Z 0.1µF/25V	CHD1EZB0F104
C450	CHIP CERAMIC CAP. CH J 270pF/50V	CHD1JJBCH271
C492	ELECTROLYTIC CAP. 1µF/50V M H7	CE1JMAVSL1R0
C552	FILM CAP.(P) 0.047µF/50V J or	CMA1JJS00473
	FILM CAP.(P) 0.047µF/50V J	CA1J473MS029
C553	ELECTROLYTIC CAP. 2.2µF/50V M LL or	CE1JMASLL2R2
	ELECTROLYTIC CAP. 2.2µF/50V LL	CE1JMASLH2R2
C555	ELECTROLYTIC CAP. 47µF/35V M or	CE1GMASDL470
	ELECTROLYTIC CAP. 47µF/35V M	CE1GMASTL470
C556	ELECTROLYTIC CAP. 1000µF/25V M or	CE1EMZPDL102
	ELECTROLYTIC CAP. 1000µF/25V M	CE1EMZPTL102
C558	CHIP CERAMIC CAP. B K 0.01µF/50V	CHD1JKB0B103
C559	ELECTROLYTIC CAP. 330µF/35V M or	CE1GMZPDL331
	ELECTROLYTIC CAP. 330µF/35V M	CE1GMZPTL331
C560	FILM CAP.(P) 0.01µF/50V J or	CMA1JJS00103
	FILM CAP.(P) 0.01µF/50V J	CA1J103MS029
C571▲	P.P. CAP 0.33µF/200V J or	CA2D334VC013
▲	PP CAP. 0.33µF/250V J	CT2E334MS041
C574▲	ELECTROLYTIC CAP. 4.7µF/250V M or	CE2EMASDL4R7
▲	ELECTROLYTIC CAP. 4.7µF/250V M	CE2EMASTL4R7
C577	FILM CAP.(P) 0.01µF/50V J or	CMA1JJS00103
	FILM CAP.(P) 0.01µF/50V J	CA1J103MS029
C578	ELECTROLYTIC CAP. 47µF/25V M or	CE1EMASDL470
	ELECTROLYTIC CAP. 47µF/25V M	CE1EMASTL470
C580▲	P.P. CAP 0.0082µF/1.6K J or	CA3C822VC010
▲	PP CAP. 0.0082µF/1.6KV J or	CT3C822MS039
▲	PP CAP. 0.0082µF/1.6KV J	CBH3CJQ00822
C584▲	ELECTROLYTIC CAP. 1µF/160V M or	CE2CMASDL1R0
▲	ELECTROLYTIC CAP. 1µF/160V M	CE2CMASTL010
C591▲	ELECTROLYTIC CAP. 1µF/50V M or	CE1JMASDL1R0
▲	ELECTROLYTIC CAP. 1µF/50V M or	CE1JMASDL010
▲	ELECTROLYTIC CAP. 1µF/50V M	CE1JMASTL1R0
C592▲	ELECTROLYTIC CAP. 47µF/35V M or	CE1GMASDL470
▲	ELECTROLYTIC CAP. 47µF/35V M	CE1GMASTL470
C594	ELECTROLYTIC CAP. 100µF/160V M or	CE2CMZPDL101
	ELECTROLYTIC CAP. 100µF/160V M	CE2CMZZTL101
C602▲	SAFETY CAP. 4700pF/250V KX	CA2E472MR050
C604▲	SAFETY CAP. 1000pF/250V KX	CA2E102MR050
C605▲	METALLIZED FILM CAP. 0.1µF/250V or	CT2E104MS037
▲	FILM CAP.(MP) 0.1µF/250V K	CT2E104DC011
C606	CERAMIC CAP. F Z 0.01µF/500V or	CCD2JZD0F103
	CERAMIC CAP. 0.01µF/AC250V	CCD2EZA0F103
C607	CERAMIC CAP. F Z 0.01µF/500V or	CCD2JZD0F103
	CERAMIC CAP. 0.01µF/AC250V	CCD2EZA0F103
C608	CERAMIC CAP. F Z 0.01µF/500V or	CCD2JZD0F103
	CERAMIC CAP. 0.01µF/AC250V	CCD2EZA0F103
C609	CERAMIC CAP. F Z 0.01µF/500V or	CCD2JZD0F103
	CERAMIC CAP. 0.01µF/AC250V	CCD2EZA0F103
C610▲	ELECTROLYTIC CAPACITOR 150µF/200V or	CA2D151S6012
▲	ALUMINIUM ELECTROLYTIC CAP 150µF/200V	CA2D151NC088
C611	CERAMIC CAP. BN 680pF/2KV or	CCD3DKA0B681
	CERAMIC CAP. LB 680pF/2K or	CA3D681KG004
	CERAMIC CAP. 680pF/2KV	CA3D681PAN04
C612	FILM CAP.(P) 0.033µF/50V J or	CMA1JJS00333
	FILM CAP.(P) 0.033µF/50V J	CA1J333MS029
C613	FILM CAP.(P) 0.0012µF/50V J or	CMA1JJS00122
	FILM CAP.(P) 0.0012µF/50V J	CA1J122MS029
C614▲	FILM CAP.(P) 0.056µF/50V J or	CMA1JJS00563
▲	FILM CAP.(P) 0.056µF/50V J	CA1J563MS029
C615	CERAMIC CAP. BN 680pF/2KV or	CCD3DKA0B681
	CERAMIC CAP. LB 680pF/2K or	CA3D681KG004

Ref. No.	Description	Part No.
	CERAMIC CAP. 680pF/2KV	CA3D681PAN04
C616▲	ELECTROLYTIC CAP. 100µF/160V M or	CE2CMZPDL101
▲	ELECTROLYTIC CAP. 100µF/160V M	CE2CMZTL101
C617▲	ELECTROLYTIC CAP. 470µF/35V M or	CE1GMZPDL471
▲	ELECTROLYTIC CAP. 470µF/35V M	CE1GMZPTL471
C618▲	ELECTROLYTIC CAP. 1000µF/16V M or	CE1CMZPDL102
▲	ELECTROLYTIC CAP. 1000µF/16V M	CE1CMZPTL102
C619▲	ELECTROLYTIC CAP. 470µF/16V M or	CE1CMASDL471
▲	ELECTROLYTIC CAP. 470µF/16V M	CE1CMASTL471
C620▲	ELECTROLYTIC CAP. 1000µF/16V M or	CE1CMZPDL102
▲	ELECTROLYTIC CAP. 1000µF/16V M	CE1CMZPTL102
C622	CERAMIC CAP.(AX) SL J 68pF/50V	CCA1J1TSL680
C623	FILM CAP.(P) 0.01µF/50V J or	CMA1JJS00103
	FILM CAP.(P) 0.01µF/50V J	CA1J103MS029
C624	CHIP CERAMIC CAP. B K 0.01µF/50V	CHD1JKB0B103
C625	ELECTROLYTIC CAP. 1µF/50V M or	CE1JMASDL1R0
	ELECTROLYTIC CAP. 1µF/50V M or	CE1JMASDL010
	ELECTROLYTIC CAP. 1µF/50V M	CE1JMASTL1R0
C626	ELECTROLYTIC CAP. 4.7µF/50V M or	CE1JMASDL4R7
	ELECTROLYTIC CAP. 4.7µF/50V M	CE1JMASTL4R7
C628	ELECTROLYTIC CAP. 10µF/50V M or	CE1JMASDL100
	ELECTROLYTIC CAP. 10µF/50V M	CE1JMASTL100
C629	ELECTROLYTIC CAP. 47µF/25V M or	CE1EMASDL470
	ELECTROLYTIC CAP. 47µF/25V M	CE1EMASTL470
C630	ELECTROLYTIC CAP. 100µF/10V M or	CE1AMASDL101
	ELECTROLYTIC CAP. 100µF/10V M	CE1AMASTL101
C631	ELECTROLYTIC CAP. 220µF/6.3V M or	CE0KMASDL221
	ELECTROLYTIC CAP. 220µF/6.3V M	CE0KMASTL221
C632	ELECTROLYTIC CAP. 100µF/16V M or	CE1CMASDL101
	ELECTROLYTIC CAP. 100µF/16V M	CE1CMASTL101
C633	ELECTROLYTIC CAP. 220µF/16V M or	CE1CMASDL221
	ELECTROLYTIC CAP. 220µF/16V M	CE1CMASTL221
C634	ELECTROLYTIC CAP. 100µF/10V M or	CE1AMASDL101
	ELECTROLYTIC CAP. 100µF/10V M	CE1AMASTL101
C635	ELECTROLYTIC CAP. 47µF/25V M or	CE1EMASDL470
	ELECTROLYTIC CAP. 47µF/25V M	CE1EMASTL470
C636	CHIP CERAMIC CAP. F Z 0.1µF/50V or	CHD1JZB0F104
	CHIP CERAMIC CAP. F Z 0.1µF/25V	CHD1EZB0F104
C640	CERAMIC CAP.(AX) B K 2200pF/50V	CA1J222TU011
C801	ELECTROLYTIC CAP. 220µF/16V M or	CE1CMASDL221
	ELECTROLYTIC CAP. 220µF/16V M	CE1CMASTL221
C802	ELECTROLYTIC CAP. 470µF/16V M or	CE1CMASDL471
	ELECTROLYTIC CAP. 470µF/16V M	CE1CMASTL471
C803	ELECTROLYTIC CAP. 10µF/50V M or	CE1JMASDL100
	ELECTROLYTIC CAP. 10µF/50V M	CE1JMASTL100
C804	ELECTROLYTIC CAP. 0.22µF/50V M or	CE1JMASDLR22
	ELECTROLYTIC CAP. 0.22µF/50V M	CE1JMASTLR22
C805	CHIP CERAMIC CAP. B K 4700pF/50V	CHD1JKB0B472
C853	CHIP CERAMIC CAP. B K 0.033µF/50V or	CHD1JKB0B333
	CHIP CERAMIC CAP. B K 0.033µF/25V	CHD1EKB0B333
C854	ELECTROLYTIC CAP. 22µF/16V M H7	CE1CMAVSL220
C856	CHIP CERAMIC CAP. F Z 0.1µF/50V or	CHD1JZB0F104
	CHIP CERAMIC CAP. F Z 0.1µF/25V	CHD1EZB0F104
C857	ELECTROLYTIC CAP. 33µF/10V H7	CE1AMAVSL330
C858	ELECTROLYTIC CAP. 4.7µF/50V M H7	CE1JMAVSL4R7
C859	CHIP CERAMIC CAP. B K 0.015µF/50V	CHD1JKB0B153
C860	CHIP CERAMIC CAP.(MELF) Y K 1000pF/35V	CZM1GKB0Y102
C861	CHIP CERAMIC CAP. CH J 100pF/50V	CHD1JJBCH101
C862	CHIP CERAMIC CAP. B K 0.01µF/50V	CHD1JKB0B103
C863	ELECTROLYTIC CAP. 10µF/25V M H7	CE1EMAVSL100
C864	ELECTROLYTIC CAP. 10µF/25V M H7	CE1EMAVSL100

Ref. No.	Description	Part No.
C865	CHIP CERAMIC CAP.(MELF) Y K 1000pF/35V	CZM1GKB0Y102
C866	CHIP CERAMIC CAP.(MELF) Y K 2200pF/35V	CZM1GKB0Y222
C872	ELECTROLYTIC CAP. 47µF/6.3V M H7	CE0KMAVSL470
C873	ELECTROLYTIC CAP. 100µF/16V M H7	CE1CMAVSL101
C874	CERAMIC CAP. B K 470pF/100V or	CCD2AKS0B471
	CERAMIC CAP. B K 470pF/500V	CCD2JKS0B471
C875	FILM CAP.(P) 0.018µF/100V J or	CMA2AJS00183
	FILM CAP.(P) 0.018µF/50V J	CA1J183MS029
CONNECTORS		
CN303	CONNECTOR BASE, 5P TUC-P05P-B1	J3TUA05TG001
CN571	CONNECTOR BASE, 5P TV-50P-05-V3 or	J3TVC05TG002
	CONNECTOR BASE, 5P RTB-1.5-5P	J3RTC05JG001
CN601	CONNECTOR BASE, 2P TV-50P-02-V3 or	J3TVC02TG002
	CONNECTOR BASE, 2P RTB-1.5-2P	J3RTC02JG001
CN802	STRAIGHT CONNECTOR BASE 00 8283 0212 00 000 or	J383C02UG002
	STRAIGHT PIN HEADER, 2P 173981-2	1770258
DIODES		
D002	ZENER DIODE MTZJT-775.6B or	QDTB0MTZJ5R6
	ZENER DIODE DZ-5.6BSBT265	NDTB0DZ5R6BS
D003	ZENER DIODE MTZJT-775.6B or	QDTB0MTZJ5R6
	ZENER DIODE DZ-5.6BSBT265	NDTB0DZ5R6BS
D203	LED SIR-563ST3F P or	QPQPS1R563ST
	LED SIR-563ST3F Q	QPQQS1R563ST
D204	LED LTL-4214M1 or	NPQZLTL4214M
	LED(RED)L-FORMING LT1814G-81-FL or	NP4Z0LT1814G
	LED L-53HT or	NP4Z000L53HT
	LED LAMP 333HT/F45-50K or	NPWK333HTF45
	LED LAMP 333HT/F45-50L or	NPWL333HTF45
	LED LAMP 333HT/F45-50M	NPWM333HTF45
D215	CARBON RES. 1/4W J 680 Ω or	RCX4JATZ0681
	CARBON RES. 1/6W J 680 Ω	RCX6JATZ0681
D216	ZENER DIODE MTZJT-775.6B or	QDTB0MTZJ5R6
	ZENER DIODE DZ-5.6BSBT265	NDTB0DZ5R6BS
D227	SWITCHING DIODE 1SS133(T-77) or	QDTZ001SS133
	SWITCHING DIODE 1N4148	NDTZ001N4148
D228	ZENER DIODE MTZJT-776.2B or	QDTB0MTZJ6R2
	ZENER DIODE DZ-6.2BSBT265	NDTB0DZ6R2BS
D301	SWITCHING DIODE 1SS133(T-77) or	QDTZ001SS133
	SWITCHING DIODE 1N4148	NDTZ001N4148
D304	SWITCHING DIODE 1SS133(T-77) or	QDTZ001SS133
	SWITCHING DIODE 1N4148	NDTZ001N4148
D305	SWITCHING DIODE 1SS133(T-77) or	QDTZ001SS133
	SWITCHING DIODE 1N4148	NDTZ001N4148
D306	SWITCHING DIODE 1SS133(T-77) or	QDTZ001SS133
	SWITCHING DIODE 1N4148	NDTZ001N4148
D307	SWITCHING DIODE 1SS133(T-77) or	QDTZ001SS133
	SWITCHING DIODE 1N4148	NDTZ001N4148
D308	ZENER DIODE MTZJT-775.6B or	QDTB0MTZJ5R6
	ZENER DIODE DZ-5.6BSBT265	NDTB0DZ5R6BS
D310	ZENER DIODE MTZJT-775.6B or	QDTB0MTZJ5R6
	ZENER DIODE DZ-5.6BSBT265	NDTB0DZ5R6BS
D311	ZENER DIODE MTZJT-775.6B or	QDTB0MTZJ5R6
	ZENER DIODE DZ-5.6BSBT265	NDTB0DZ5R6BS
D312	SWITCHING DIODE 1SS133(T-77) or	QDTZ001SS133
	SWITCHING DIODE 1N4148	NDTZ001N4148
D313	SWITCHING DIODE 1SS133(T-77) or	QDTZ001SS133
	SWITCHING DIODE 1N4148	NDTZ001N4148
D314	ZENER DIODE MTZJT-779.1B or	QDTB0MTZJ9R1
	ZENER DIODE DZ-9.1BSBT265	NDTB0DZ9R1BS
D401	SWITCHING DIODE 1SS133(T-77) or	QDTZ001SS133

Ref. No.	Description	Part No.
	SWITCHING DIODE 1N4148	NDT2001N4148
D552	DIODE 1N5397-B or	NDL2001N5397
	RECTIFIER DIODE ERB12-06	QDQZ0ERB1206
D571▲	DIODE FR154 or	NDL2000FR154
▲	FAST RECOVERY DIODE ERB44-02	QDPZ0ERB4402
D572▲	DIODE FR104-B or	NDL2000FR104
▲	RECTIFIER DIODE 10ELS2 or	QDQZ0010ELS2
▲	RECTIFIER DIODE ERA22-02	QDPZ0ERA2202
D584▲	SWITCHING DIODE 1SS133(T-77) or	QDTZ001SS133
▲	SWITCHING DIODE 1N4148	NDT2001N4148
D585	ZENER DIODE MTZJT-775.1B or	QDTB0MTZJ5R1
	ZENER DIODE DZ-5.1BSBT265	NDTB0DZ5R1BS
D591▲	ZENER DIODE MTZJT-7736B or	QDTB00MTZJ36
▲	ZENER DIODE DZ-36BSBT265	NDTB00DZ36BS
D593▲	PCB JUMPER D0.6-P5.0	JW5.0T
D595▲	ZENER DIODE MTZJT-7720B or	QDTB00MTZJ20
▲	ZENER DIODE DZ-20BSBT265	NDTB00DZ20BS
D596▲	SWITCHING DIODE 1SS133(T-77) or	QDTZ001SS133
▲	SWITCHING DIODE 1N4148	NDT2001N4148
D597▲	SWITCHING DIODE 1SS133(T-77) or	QDTZ001SS133
▲	SWITCHING DIODE 1N4148	NDT2001N4148
D598▲	DIODE FR104-B or	NDL2000FR104
▲	RECTIFIER DIODE 10ELS2 or	QDQZ0010ELS2
▲	RECTIFIER DIODE ERA22-02	QDPZ0ERA2202
D601	PCB JUMPER D0.6-P10.0	JW10.0T
D603▲	DIODE 1N5397-B or	NDL2001N5397
▲	RECTIFIER DIODE ERB12-06	QDQZ0ERB1206
D604▲	DIODE 1N5397-B or	NDL2001N5397
▲	RECTIFIER DIODE ERB12-06	QDQZ0ERB1206
D605▲	DIODE 1N5397-B or	NDL2001N5397
▲	RECTIFIER DIODE ERB12-06	QDQZ0ERB1206
D606▲	DIODE 1N5397-B or	NDL2001N5397
▲	RECTIFIER DIODE ERB12-06	QDQZ0ERB1206
D607▲	ZENER DIODE MTZJT-7720C or	QDTC00MTZJ20
▲	ZENER DIODE DZ-20BSCT265	NDTC00DZ20BS
D608	ZENER DIODE MTZJT-7736A or	QDTA00MTZJ36
	ZENER DIODE DZ-36BSAT265	NDTA00DZ36BS
D609▲	SWITCHING DIODE 1SS133(T-77) or	QDTZ001SS133
▲	SWITCHING DIODE 1N4148	NDT2001N4148
D610	ZENER DIODE MTZJT-775.6B or	QDTB0MTZJ5R6
	ZENER DIODE DZ-5.6BSBT265	NDTB0DZ5R6BS
D611	SWITCHING DIODE 1SS133(T-77) or	QDTZ001SS133
	SWITCHING DIODE 1N4148	NDT2001N4148
D613▲	FAST RECOVERY DIODE CA201-4 or	QDWZ00CA2014
▲	RECOVERY DIODE ERC18-04	QDZZ0ERC1804
D614▲	DIODE FR104-B or	NDL2000FR104
▲	RECTIFIER DIODE 10ELS2 or	QDQZ0010ELS2
▲	RECTIFIER DIODE ERA22-02	QDPZ0ERA2202
D615▲	DIODE 1ZC33 or	QDQZ0001ZC33
▲	ZENER DIODE RD33FB	QDQZ000RD33F
D616▲	SCHOTTKY BARRIER DIODE 21DQ04 or	QDQZ0021DQ04
▲	SCHOTTKY BARRIER DIODE ERB81-004	AERB81004***
D617▲	SCHOTTKY BARRIER DIODE 11EQS04 or	QD4Z011EQS04
▲	SCHOTTKY BARRIER DIODE ERA81-004	QDPZERA81004
D618▲	SCHOTTKY BARRIER DIODE 11EQS04 or	QD4Z011EQS04
▲	SCHOTTKY BARRIER DIODE ERA81-004	QDPZERA81004
D619	DIODE FR104-B or	NDL2000FR104
	RECTIFIER DIODE 10ELS2 or	QDQZ0010ELS2
	RECTIFIER DIODE ERA22-02	QDPZ0ERA2202
D620▲	ZENER DIODE MTZJT-776.8B or	QDTB0MTZJ6R8
▲	ZENER DIODE DZ-6.8BSBT265	NDTB0DZ6R8BS

Ref. No.	Description	Part No.
D621▲	SWITCHING DIODE 1SS133(T-77) or	QDTZ001SS133
▲	SWITCHING DIODE 1N4148	NDT2001N4148
D622▲	SWITCHING DIODE 1SS133(T-77) or	QDTZ001SS133
▲	SWITCHING DIODE 1N4148	NDT2001N4148
D623▲	SWITCHING DIODE 1SS133(T-77) or	QDTZ001SS133
▲	SWITCHING DIODE 1N4148	NDT2001N4148
D626	ZENER DIODE MTZJT-7736A or	QDTA00MTZJ36
	ZENER DIODE DZ-36BSAT265	NDTA00DZ36BS
D627▲	ZENER DIODE MTZJT-7713A or	QDTA00MTZJ13
▲	ZENER DIODE DZ-13BSAT265	NDTA00DZ13BS
D628▲	SWITCHING DIODE 1SS133(T-77) or	QDTZ001SS133
▲	SWITCHING DIODE 1N4148	NDT2001N4148
D629	SWITCHING DIODE 1SS133(T-77) or	QDTZ001SS133
	SWITCHING DIODE 1N4148	NDT2001N4148
D630▲	PCB JUMPER D0.6-P5.0	JW5.0T
D631	ZENER DIODE MTZJT-776.8A or	QDTA0MTZJ6R8
	ZENER DIODE DZ-6.8BSAT265	NDTA0DZ6R8BS
D632	SWITCHING DIODE 1SS133(T-77) or	QDTZ001SS133
	SWITCHING DIODE 1N4148	NDT2001N4148
D633	SWITCHING DIODE 1SS133(T-77) or	QDTZ001SS133
	SWITCHING DIODE 1N4148	NDT2001N4148
D634	ZENER DIODE MTZJT-778.2B or	QDTB0MTZJ8R2
	ZENER DIODE DZ-8.2BSBT265	NDTB0DZ8R2BS
D635	SWITCHING DIODE 1SS133(T-77) or	QDTZ001SS133
	SWITCHING DIODE 1N4148	NDT2001N4148
D636	SWITCHING DIODE 1SS133(T-77) or	QDTZ001SS133
	SWITCHING DIODE 1N4148	NDT2001N4148
D638▲	SWITCHING DIODE 1SS133(T-77) or	QDTZ001SS133
▲	SWITCHING DIODE 1N4148	NDT2001N4148
D640▲	SWITCHING DIODE 1SS133(T-77) or	QDTZ001SS133
▲	SWITCHING DIODE 1N4148	NDT2001N4148
D641▲	ZENER DIODE MTZJT-7736A or	QDTA00MTZJ36
▲	ZENER DIODE DZ-36BSAT265	NDTA00DZ36BS
D646	SWITCHING DIODE 1SS133(T-77) or	QDTZ001SS133
	SWITCHING DIODE 1N4148	NDT2001N4148
D647	SWITCHING DIODE 1SS133(T-77) or	QDTZ001SS133
	SWITCHING DIODE 1N4148	NDT2001N4148
D648	SWITCHING DIODE 1SS133(T-77) or	QDTZ001SS133
	SWITCHING DIODE 1N4148	NDT2001N4148
D649▲	SWITCHING DIODE 1SS133(T-77) or	QDTZ001SS133
▲	SWITCHING DIODE 1N4148	NDT2001N4148
D801▲	SWITCHING DIODE 1SS133(T-77) or	QDTZ001SS133
▲	SWITCHING DIODE 1N4148	NDT2001N4148
ICS		
IC201▲	MICROCONTROLLER 16BIT M37760M8H1D8GP	QSZAA0RMB096
IC202	IC:MEMORY BR24C02F-W or	QSMBA0SRM003
	IC:MEMORY AT24C02N-10SC or	NSMMA0SAZ012
	IC(EEPROM) M24C02-MN6 or	NSMMA0SSS028
	IC:MEMORY BR24C02F	QSMMA0SRM003
IC301▲	IC:CHROMA/IF 1 CHIP M61210FP-R60* or	QSZAA0RMB086
▲	IC:CHROMA/IF 1 CHIP M61210FP-R61 or	QSZAB0RMB086
▲	IC:CHROMA/IF 1 CHIP M61210FP-R62*	QSZAC0RMB086
IC401	IC:Y/C/A LA71091M	QSZBA0RSY012
IC551▲	VERTICAL OUTPUT IC AN5522 or	QSZBA0SMS002
▲	VERTICAL OUTPUT IC LA78040A	QSBBA0SSY003
IC601▲	PHOTOCOUPLER LTV-817B-F or	NPEB0LTV817F
▲	PHOTOCOUPLER LTV-817C-F or	NPECOLTV817F
▲	PHOTO COUPLER PC817X6	QPE600PC817X
IC602▲	VOLTAGE REGULATOR KIA7805API or	NSBBA0SJY011
▲	VOLTAGE REGULATOR KA7805A or	NSZBA0SF3052

Ref. No.	Description	Part No.
▲	IC:VOLTAGE REGULATOR AN7805F	AN7805F
IC801	AUDIO AMP LA4224	QSZA00SSY005
COILS		
L001	PCB JUMPER D0.6-P5.0	JW5.0T
L211▲	CHOKE COIL 47μH-K	LLBD00PKV007
L301	PCB JUMPER D0.6-P5.0	JW5.0T
L302	INDUCTOR 15μH-J-26T or	LLAXJATTU150
	INDUCTOR 15μH-K-26T	LLAXKDTKA150
L303	INDUCTOR 12μH-J-26T or	LLAXJATTU120
	INDUCTOR 12μH-K-26T	LLAXKDTKA120
L305	INDUCTOR 1.0μH-J-26T or	LLAXJATTU1R0
	INDUCTOR 1.0μH-K-26T	LLAXKDTKA1R0
L306	PCB JUMPER D0.6-P5.0	JW5.0T
L402	INDUCTOR 22μH-J-26T or	LLAXJATTU220
	INDUCTOR 22μH-K-26T	LLAXKDTKA220
L404	CHOKE COIL 47μH-K	LLBD00PKV007
L505	CHOKE COIL 47μH-K	LLBD00PKV007
L572	CHOKE COIL 47μH-K	LLBD00PKV007
L601▲	LINE FILTER SA-91213B or	LLBG00ZSA002
▲	LINE FILTER TLF12UA302W1R0 or	LLBG00ZTU025
▲	LINE FILTER 5.0MH 6Y075 or	LLBG00ZKT004
▲	LINE FILTER UU10.5-A or	LLBG00ZY2008
▲	LINE FILTER TLF14CB3321R0 or	LLBG00ZTU012
▲	LINE FILTER 6.35MH UU10-002	LLBG00ZKV001
L872	INDUCTOR 47μH-K-5FT or	LLARKBSTU470
	INDUCTOR 47μH-K-5FT	LLARKDSKA470
TRANSISTORS		
Q205	TRANSISTOR 2SC2785(F) or	QGSF02SC2785
	TRANSISTOR 2SC2785(H) or	QGSF02SC2785
	TRANSISTOR 2SC2785(J) or	QGSJ02SC2785
	TRANSISTOR KTC3199(GR) or	NQS10KTC3199
	TRANSISTOR KTC3198(GR) or	NQS40KTC3198
	TRANSISTOR 2SC1815-GR(TPE2)	QGS102SC1815
Q206	PHOTO TRANSISTOR PT204-6B-12 or	NPWZT2046B12
	PHOTO TRANSISTOR MID-32A22	NPWZM1D32A22
Q301	TRANSISTOR 2SC2785(F) or	QGSF02SC2785
	TRANSISTOR 2SC2785(H) or	QGSF02SC2785
	TRANSISTOR 2SC2785(J) or	QGSJ02SC2785
	TRANSISTOR KTC3199(GR) or	NQS10KTC3199
	TRANSISTOR KTC3198(GR) or	NQS40KTC3198
	TRANSISTOR 2SC1815-GR(TPE2)	QGS102SC1815
Q302	TRANSISTOR 2SC2785(F) or	QGSF02SC2785
	TRANSISTOR 2SC2785(H) or	QGSF02SC2785
	TRANSISTOR 2SC2785(J) or	QGSJ02SC2785
	TRANSISTOR KTC3199(GR) or	NQS10KTC3199
	TRANSISTOR KTC3198(GR) or	NQS40KTC3198
	TRANSISTOR 2SC1815-GR(TPE2)	QGS102SC1815
Q401	TRANSISTOR 2SA1175(F) or	QGSF02SA1175
	TRANSISTOR KTA1267(GR) or	NQS10KTA1267
	TRANSISTOR KTA1266(GR) or	NQS40KTA1266
	TRANSISTOR 2SA1015-GR(TPE2)	QGS102SA1015
Q402	TRANSISTOR 2SA1175(F) or	QGSF02SA1175
	TRANSISTOR KTA1267(GR) or	NQS10KTA1267
	TRANSISTOR KTA1266(GR) or	NQS40KTA1266
	TRANSISTOR 2SA1015-GR(TPE2)	QGS102SA1015
Q491	TRANSISTOR 2SC2785(F) or	QGSF02SC2785
	TRANSISTOR 2SC2785(H) or	QGSF02SC2785
	TRANSISTOR 2SC2785(J) or	QGSJ02SC2785
	TRANSISTOR KTC3199(GR) or	NQS10KTC3199
	TRANSISTOR KTC3198(GR) or	NQS40KTC3198

Ref. No.	Description	Part No.
	TRANSISTOR 2SC1815-GR(TPE2)	QGS102SC1815
Q571▲	TRANSISTOR TT2084LS-YB11 or	QQZZ00TT2084
▲	TRANSISTOR 2SD2627LS-FEC-YB11	QQZZ02SD2627
Q572	TRANSISTOR 2SC1627Y-TPE2	QGSY02SC1627
Q591▲	TRANSISTOR 2SC2785(F) or	QGSF02SC2785
▲	TRANSISTOR 2SC2785(H) or	QGSF02SC2785
▲	TRANSISTOR 2SC2785(J) or	QGSJ02SC2785
▲	TRANSISTOR KTC3199(GR) or	NQS10KTC3199
▲	TRANSISTOR KTC3198(GR) or	NQS40KTC3198
▲	TRANSISTOR 2SC1815-GR(TPE2)	QGS102SC1815
Q601▲	MOS FET 2SK2662	QF5Z02SK2662
Q602▲	TRANSISTOR 2SC2120-O-TPE2 or	QGS002SC2120
▲	TRANSISTOR 2SC2120-Y(TPE2)	QGSY02SC2120
Q604▲	TRANSISTOR 2SC2785(F) or	QGSF02SC2785
▲	TRANSISTOR 2SC2785(H) or	QGSF02SC2785
▲	TRANSISTOR 2SC2785(J) or	QGSJ02SC2785
▲	TRANSISTOR 2SC1815-GR(TPE2)	QGS102SC1815
Q605	TRANSISTOR 2SC2785(F) or	QGSF02SC2785
	TRANSISTOR 2SC2785(H) or	QGSF02SC2785
	TRANSISTOR 2SC2785(J) or	QGSJ02SC2785
	TRANSISTOR KTC3199(GR) or	NQS10KTC3199
	TRANSISTOR KTC3198(GR) or	NQS40KTC3198
	TRANSISTOR 2SC1815-GR(TPE2)	QGS102SC1815
Q606▲	TRANSISTOR 2SA950(O) or	Q2SA9500TPE2
▲	TRANSISTOR 2SA950(Y) or	Q2SA950YTPE2
▲	TRANSISTOR KTA1271(Y)	NQSY0KTA1271
Q607	TRANSISTOR 2SC2785(F) or	QGSF02SC2785
	TRANSISTOR 2SC2785(H) or	QGSF02SC2785
	TRANSISTOR 2SC2785(J) or	QGSJ02SC2785
	TRANSISTOR KTC3199(GR) or	NQS10KTC3199
	TRANSISTOR KTC3198(GR) or	NQS40KTC3198
	TRANSISTOR 2SC1815-GR(TPE2)	QGS102SC1815
Q608▲	TRANSISTOR 2SC2120-O-TPE2 or	QGS002SC2120
▲	TRANSISTOR 2SC2120-Y(TPE2) or	QGSY02SC2120
▲	TRANSISTOR KTC3203(Y)	NQSY0KTC3203
Q609	TRANSISTOR 2SC2120-O-TPE2 or	QGS002SC2120
	TRANSISTOR 2SC2120-Y(TPE2) or	QGSY02SC2120
	TRANSISTOR KTC3203(Y)	NQSY0KTC3203
Q610▲	TRANSISTOR 2SC2785(F) or	QGSF02SC2785
▲	TRANSISTOR 2SC2785(H) or	QGSF02SC2785
▲	TRANSISTOR 2SC2785(J) or	QGSJ02SC2785
▲	TRANSISTOR KTC3199(GR) or	NQS10KTC3199
▲	TRANSISTOR KTC3198(GR) or	NQS40KTC3198
▲	TRANSISTOR 2SC1815-GR(TPE2)	QGS102SC1815
Q611▲	TRANSISTOR 2SD400(F)	QQUF00SD400
Q612	RES. BUILT-IN TRANSISTOR KRA103M or	NQSZ0KRA103M
	RES. BUILT-IN TRANSISTOR BN1F4M-T	QGSZ00BN1F4M
Q871	TRANSISTOR 2SA1175(F) or	QGSF02SA1175
	TRANSISTOR KTA1267(GR) or	NQS10KTA1267
	TRANSISTOR KTA1266(GR) or	NQS40KTA1266
	TRANSISTOR 2SA1015-GR(TPE2)	QGS102SA1015
Q872	TRANSISTOR 2SC2120-O-TPE2 or	QGS002SC2120
	TRANSISTOR 2SC2120-Y(TPE2) or	QGSY02SC2120
	TRANSISTOR KTC3203(Y)	NQSY0KTC3203
Q873	TRANSISTOR 2SC3331(T) or	QSC3331TNPAA
	TRANSISTOR 2SC3331(U) or	QSC3331UNPAA
	TRANSISTOR 2SC1815-GR(TPE2)	QGS102SC1815
Q874	TRANSISTOR 2SC3331(T) or	QSC3331TNPAA
	TRANSISTOR 2SC3331(U) or	QSC3331UNPAA
	TRANSISTOR 2SC1815-GR(TPE2)	QGS102SC1815
Q875	RES. BUILT-IN TRANSISTOR KRA103M or	NQSZ0KRA103M

Ref. No.	Description	Part No.
	RES. BUILT-IN TRANSISTOR BN1F4M-T	QQSZ00BN1F4M
RESISTORS		
R001	CHIP RES.(1608) 1/10W J 1k Ω	RRXAJB5Z0102
R004	CHIP RES.(1608) 1/10W J 100 Ω	RRXAJB5Z0101
R007	CHIP RES.(1608) 1/10W J 100 Ω	RRXAJB5Z0101
R008	CHIP RES.(1608) 1/10W J 100 Ω	RRXAJB5Z0101
R201	CARBON RES. 1/4W G 4.7k Ω or	RCX4GATZ0472
	CARBON RES. 1/6W G 4.7k Ω	RCX6GATZ0472
R202	CARBON RES. 1/4W G 22k Ω or	RCX4GATZ0223
	CARBON RES. 1/6W G 22k Ω	RCX6GATZ0223
R203	CARBON RES. 1/4W G 470 Ω or	RCX4GATZ0471
	CARBON RES. 1/6W G 470 Ω	RCX6GATZ0471
R204	CARBON RES. 1/4W G 1.5k Ω or	RCX4GATZ0152
	CARBON RES. 1/6W G 1.5k Ω	RCX6GATZ0152
R205	CARBON RES. 1/4W G 3.6k Ω or	RCX4GATZ0362
	CARBON RES. 1/6W G 3.6k Ω	RCX6GATZ0362
R206	CARBON RES. 1/4W G 10k Ω or	RCX4GATZ0103
	CARBON RES. 1/6W G 10k Ω	RCX6GATZ0103
R207	CHIP RES.(1608) 1/10W J 22k Ω	RRXAJB5Z0223
R208	CHIP RES.(1608) 1/10W J 22k Ω	RRXAJB5Z0223
R209	CHIP RES.(1608) 1/10W J 10k Ω	RRXAJB5Z0103
R210	CHIP RES.(1608) 1/10W J 1.5k Ω	RRXAJB5Z0152
R211	CHIP RES.(1608) 1/10W J 1.5k Ω	RRXAJB5Z0152
R212	CHIP RES.(1608) 1/10W J 2.2k Ω	RRXAJB5Z0222
R213	CHIP RES.(1608) 1/10W J 2.7k Ω	RRXAJB5Z0272
R214	CHIP RES.(1608) 1/10W J 10k Ω	RRXAJB5Z0103
R215	CHIP RES.(1608) 1/10W J 1.5k Ω	RRXAJB5Z0152
R216	CHIP RES.(1608) 1/10W J 1.5k Ω	RRXAJB5Z0152
R217	CHIP RES.(1608) 1/10W J 2.2k Ω	RRXAJB5Z0222
R218	CHIP RES.(1608) 1/10W J 2.7k Ω	RRXAJB5Z0272
R219	CARBON RES. 1/4W J 1k Ω or	RCX4JATZ0102
	CARBON RES. 1/6W J 1k Ω	RCX6JATZ0102
R220	CHIP RES.(1608) 1/10W J 470k Ω	RRXAJB5Z0474
R221	CARBON RES. 1/4W J 1k Ω or	RCX4JATZ0102
	CARBON RES. 1/6W J 1k Ω	RCX6JATZ0102
R222	CHIP RES.(1608) 1/10W J 470k Ω	RRXAJB5Z0474
R223	CHIP RES.(1608) 1/10W J 560 Ω	RRXAJB5Z0561
R224	PCB JUMPER D0.6-P5.0	JW5.0T
R225	CHIP RES.(1608) 1/10W J 100 Ω	RRXAJB5Z0101
R226	PCB JUMPER D0.6-P5.0	JW5.0T
R227	CARBON RES. 1/4W J 270 Ω or	RCX4JATZ0271
	CARBON RES. 1/6W J 270 Ω	RCX6JATZ0271
R229	CHIP RES.(1608) 1/10W J 390 Ω	RRXAJB5Z0391
R230	METAL OXIDE FILM RES. 1W J 2.2 Ω or	RN012R2ZU001
	METAL OXIDE FILM RES. 1W J 2.2 Ω	RN012R2DP003
R233	CHIP RES.(1608) 1/10W J 2.2k Ω	RRXAJB5Z0222
R234	CHIP RES.(1608) 1/10W J 1.2k Ω	RRXAJB5Z0122
R235	CHIP RES.(1608) 1/10W J 47 Ω	RRXAJB5Z0470
R236	CHIP RES.(1608) 1/10W J 100k Ω	RRXAJB5Z0104
R237	PCB JUMPER D0.6-P5.0	JW5.0T
R238	CHIP RES.(1608) 1/10W J 470k Ω	RRXAJB5Z0474
R239	CHIP RES.(1608) 1/10W J 2.7k Ω	RRXAJB5Z0272
R240	PCB JUMPER D0.6-P5.0	JW5.0T
R241	CARBON RES. 1/4W J 5.6k Ω or	RCX4JATZ0562
	CARBON RES. 1/6W J 5.6k Ω	RCX6JATZ0562
R243	CHIP RES.(1608) 1/10W J 1k Ω	RRXAJB5Z0102
R244	CHIP RES.(1608) 1/10W J 1M Ω	RRXAJB5Z0105
R245	CHIP RES.(1608) 1/10W J 470 Ω	RRXAJB5Z0471
R247	CHIP RES.(1608) 1/10W J 820 Ω	RRXAJB5Z0821
R248	CHIP RES.(1608) 1/10W J 470 Ω	RRXAJB5Z0471

Ref. No.	Description	Part No.
R249	CHIP RES.(1608) 1/10W J 3.3k Ω	RRXAJB5Z0332
R250	CHIP RES.(1608) 1/10W J 1.5k Ω	RRXAJB5Z0152
R251	CHIP RES.(1608) 1/10W J 3.3k Ω	RRXAJB5Z0332
R252	CHIP RES.(1608) 1/10W J 1.5k Ω	RRXAJB5Z0152
R253	CHIP RES.(1608) 1/10W J 3.3k Ω	RRXAJB5Z0332
R254	CHIP RES.(1608) 1/10W J 1.5k Ω	RRXAJB5Z0152
R255	PCB JUMPER D0.6-P5.0	JW5.0T
R256	CARBON RES. 1/4W J 5.6k Ω or	RCX4JATZ0562
	CARBON RES. 1/6W J 5.6k Ω	RCX6JATZ0562
R257	PCB JUMPER D0.6-P5.0	JW5.0T
R258	PCB JUMPER D0.6-P5.0	JW5.0T
R259	CARBON RES. 1/4W J 5.6k Ω or	RCX4JATZ0562
	CARBON RES. 1/6W J 5.6k Ω	RCX6JATZ0562
R260	PCB JUMPER D0.6-P5.0	JW5.0T
R261	CARBON RES. 1/4W J 6.8k Ω or	RCX4JATZ0682
	CARBON RES. 1/6W J 6.8k Ω	RCX6JATZ0682
R263	CHIP RES.(1608) 1/10W J 68k Ω	RRXAJB5Z0683
R264	CHIP RES.(1608) 1/10W J 220k Ω	RRXAJB5Z0224
R267	CHIP RES.(1608) 1/10W J 33k Ω	RRXAJB5Z0333
R269	PCB JUMPER D0.6-P5.0	JW5.0T
R270	CHIP RES.(1608) 1/10W J 100k Ω	RRXAJB5Z0104
R273	CHIP RES.(1608) 1/10W J 1.8k Ω	RRXAJB5Z0182
R274	CHIP RES.(1608) 1/10W J 680 Ω	RRXAJB5Z0681
R275	CHIP RES.(1608) 1/10W J 10k Ω	RRXAJB5Z0103
R279	CARBON RES. 1/4W J 10k Ω or	RCX4JATZ0103
	CARBON RES. 1/6W J 10k Ω	RCX6JATZ0103
R280	CARBON RES. 1/4W J 1k Ω or	RCX4JATZ0102
	CARBON RES. 1/6W J 1k Ω	RCX6JATZ0102
R281	CHIP RES.(1608) 1/10W J 1k Ω	RRXAJB5Z0102
R289	PCB JUMPER D0.6-P5.0	JW5.0T
R290	PCB JUMPER D0.6-P5.0	JW5.0T
R292	CHIP RES.(1608) 1/10W J 22k Ω	RRXAJB5Z0223
R293	PCB JUMPER D0.6-P5.0	JW5.0T
R294	CHIP RES.(1608) 1/10W J 22k Ω	RRXAJB5Z0223
R301	CHIP RES.(1608) 1/10W J 1k Ω	RRXAJB5Z0102
R302	CHIP RES.(1608) 1/10W J 22k Ω	RRXAJB5Z0223
R305	CHIP RES.(1608) 1/10W J 68k Ω	RRXAJB5Z0683
R306	CHIP RES.(1608) 1/10W J 6.8k Ω	RRXAJB5Z0682
R308	CHIP RES.(1608) 1/10W J 1.2k Ω	RRXAJB5Z0122
R309	CARBON RES. 1/4W J 22 Ω or	RCX4JATZ0220
	CARBON RES. 1/6W J 22 Ω	RCX6JATZ0220
R310	CHIP RES.(1608) 1/10W J 2.2k Ω	RRXAJB5Z0222
R311	CHIP RES.(1608) 1/10W J 2.2k Ω	RRXAJB5Z0222
R312	CHIP RES.(1608) 1/10W J 2.2k Ω	RRXAJB5Z0222
R313	CHIP RES.(1608) 1/10W J 330 Ω	RRXAJB5Z0331
R314	CHIP RES.(1608) 1/10W J 330 Ω	RRXAJB5Z0331
R315	CHIP RES.(1608) 1/10W J 330 Ω	RRXAJB5Z0331
R316	PCB JUMPER D0.6-P5.0	JW5.0T
R317	CHIP RES.(1608) 1/10W J 100 Ω	RRXAJB5Z0101
R318	CARBON RES. 1/4W J 100 Ω or	RCX4JATZ0101
	CARBON RES. 1/6W J 100 Ω	RCX6JATZ0101
R319	CARBON RES. 1/4W J 100 Ω or	RCX4JATZ0101
	CARBON RES. 1/6W J 100 Ω	RCX6JATZ0101
R320	CHIP RES.(1608) 1/10W J 120k Ω	RRXAJB5Z0124
R321	CARBON RES. 1/4W J 180k Ω or	RCX4JATZ0184
	CARBON RES. 1/6W J 180k Ω	RCX6JATZ0184
R322	CHIP RES.(1608) 1/10W J 15k Ω	RRXAJB5Z0153
R323	CHIP RES.(1608) 1/10W J 6.8k Ω	RRXAJB5Z0682
R324	CARBON RES. 1/4W J 100 Ω or	RCX4JATZ0101
	CARBON RES. 1/6W J 100 Ω	RCX6JATZ0101
R325	CHIP RES.(1608) 1/10W J 10k Ω	RRXAJB5Z0103

Ref. No.	Description	Part No.
R326	CHIP RES.(1608) 1/10W J 1k Ω	RRXAJB5Z0102
R331	CHIP RES.(1608) 1/10W J 47 Ω	RRXAJB5Z0470
R333	PCB JUMPER D0.6-P5.0	JW5.0T
R335	CHIP RES.(1608) 1/10W J 1k Ω	RRXAJB5Z0102
R336	CHIP RES.(1608) 1/10W J 390 Ω	RRXAJB5Z0391
R337	CHIP RES.(1608) 1/10W J 220 Ω	RRXAJB5Z0221
R342	CHIP RES.(1608) 1/10W J 1k Ω	RRXAJB5Z0102
R345	PCB JUMPER D0.6-P5.0	JW5.0T
R347	CHIP RES.(1608) 1/10W J 10M Ω	RRXAJB5Z0106
R350	CHIP RES.(1608) 1/10W J 68 Ω	RRXAJB5Z0680
R351	CHIP RES.(1608) 1/10W J 680 Ω	RRXAJB5Z0681
R352	CHIP RES.(1608) 1/10W J 1M Ω	RRXAJB5Z0105
R391	CHIP RES.(1608) 1/10W J 100 Ω	RRXAJB5Z0101
R392	CHIP RES.(1608) 1/10W J 100 Ω	RRXAJB5Z0101
R393	CHIP RES.(1608) 1/10W J 100 Ω	RRXAJB5Z0101
R406	CHIP RES.(1608) 1/10W J 47k Ω	RRXAJB5Z0473
R407	CHIP RES.(1608) 1/10W J 47k Ω	RRXAJB5Z0473
R408	CHIP RES.(1608) 1/10W J 47k Ω	RRXAJB5Z0473
R409	CHIP RES.(1608) 1/10W J 18k Ω	RRXAJB5Z0183
R413	CHIP RES.(1608) 1/10W J 39k Ω	RRXAJB5Z0393
R414	CHIP RES.(1608) 1/10W J 4.7k Ω	RRXAJB5Z0472
R415	CHIP RES.(1608) 1/10W J 1.5k Ω	RRXAJB5Z0152
R416	CHIP RES.(1608) 1/10W J 100k Ω	RRXAJB5Z0104
R417	CARBON RES. 1/4W J 220 Ω or CARBON RES. 1/6W J 220 Ω	RCX4JATZ0221 RCX6JATZ0221
R418	CHIP RES.(1608) 1/10W J 390 Ω	RRXAJB5Z0391
R419	CHIP RES.(1608) 1/10W J 330 Ω	RRXAJB5Z0331
R423	CHIP RES.(1608) 1/10W J 5.6M Ω	RRXAJB5Z0565
R424	CHIP RES.(1608) 1/10W J 100k Ω	RRXAJB5Z0104
R425	CHIP RES.(1608) 1/10W J 82k Ω	RRXAJB5Z0823
R426	CHIP RES.(1608) 1/10W J 2.2k Ω	RRXAJB5Z0222
R427	CARBON RES. 1/4W J 820 Ω or CARBON RES. 1/6W J 820 Ω	RCX4JATZ0821 RCX6JATZ0821
R428	CHIP RES.(1608) 1/10W J 680k Ω	RRXAJB5Z0684
R429	CHIP RES.(1608) 1/10W J 1.5k Ω	RRXAJB5Z0152
R431	CHIP RES.(1608) 1/10W J 8.2k Ω	RRXAJB5Z0822
R434	CHIP RES.(1608) 1/10W J 47k Ω	RRXAJB5Z0473
R435	CHIP RES.(1608) 1/10W J 2.2k Ω	RRXAJB5Z0222
R495	CHIP RES.(1608) 1/10W J 47k Ω	RRXAJB5Z0473
R496	CHIP RES.(1608) 1/10W J 2.2M Ω	RRXAJB5Z0225
R497	CHIP RES.(1608) 1/10W J 12k Ω	RRXAJB5Z0123
R544▲	CHIP RES.(1608) 1/10W J 10k Ω	RRXAJB5Z0103
R551	CHIP RES.(1608) 1/10W J 1.5k Ω	RRXAJB5Z0152
R552▲	CARBON RES. 1/4W J 1.5k Ω	RCX4JATZ0152
R556	CHIP RES.(1608) 1/10W J 4.7 Ω	RRXAJB5Z04R7
R557	CHIP RES.(1608) 1/10W J 470 Ω	RRXAJB5Z0471
R558	CHIP RES.(1608) 1/10W J 22k Ω	RRXAJB5Z0223
R559	CHIP RES.(1608) 1/10W J 1k Ω	RRXAJB5Z0102
R560	CARBON RES. 1/4W J 6.8k Ω or CARBON RES. 1/6W J 6.8k Ω	RCX4JATZ0682 RCX6JATZ0682
R561	CHIP RES.(1608) 1/10W J 8.2k Ω	RRXAJB5Z0822
R562	CARBON RES. 1/4W J 4.7 Ω	RCX4JATZ04R7
R563	CARBON RES. 1/4W J 4.7 Ω	RCX4JATZ04R7
R565▲	CARBON RES. 1/4W J 3.9 Ω or ▲ CARBON RES. 1/6W J 3.9 Ω	RCX4JATZ03R9 RCX6JATZ03R9
R566▲	CARBON RES. 1/4W J 3.9 Ω or ▲ CARBON RES. 1/6W J 3.9 Ω	RCX4JATZ03R9 RCX6JATZ03R9
R570▲	CARBON RES. 1/4W J 3.9 Ω or ▲ CARBON RES. 1/6W J 3.9 Ω	RCX4JATZ03R9 RCX6JATZ03R9
R571	CHIP RES.(1608) 1/10W J 1.5k Ω	RRXAJB5Z0152
R573	CARBON RES. 1/4W J 470 Ω or	RCX4JATZ0471

Ref. No.	Description	Part No.
	CARBON RES. 1/6W J 470 Ω	RCX6JATZ0471
R574▲	METAL OXIDE FILM RES. 2W J 1k Ω or ▲ METAL OXIDE FILM RES. 2W J 1k Ω	RN02102ZU001 RN02102DP004
R575▲	METAL OXIDE FILM RES. 2W J 1k Ω or ▲ METAL OXIDE FILM RES. 2W J 1k Ω	RN02102ZU001 RN02102DP004
R576	CARBON RES. 1/4W J 1k Ω or CARBON RES. 1/6W J 1k Ω	RCX4JATZ0102 RCX6JATZ0102
R577	CARBON RES. 1/4W J 560 Ω or CARBON RES. 1/6W J 560 Ω	RCX4JATZ0561 RCX6JATZ0561
R578	PCB JUMPER D0.6-P5.0	JW5.0T
R580▲	CARBON RES. 1/4W J 47 Ω or ▲ CARBON RES. 1/6W J 47 Ω	RCX4JATZ0470 RCX6JATZ0470
R583▲	METAL OXIDE FILM RES. 1W J 1.8 Ω or ▲ METAL OXIDE FILM RES. 1W J 1.8 Ω	RN011R8ZU001 RN011R8DP003
R584▲	CARBON RES. 1/4W J 1k Ω or ▲ CARBON RES. 1/6W J 1k Ω	RCX4JATZ0102 RCX6JATZ0102
R585	CARBON RES. 1/4W J 8.2k Ω or CARBON RES. 1/6W J 8.2k Ω	RCX4JATZ0822 RCX6JATZ0822
R587▲	CARBON RES. 1/4W J 100k Ω or ▲ CARBON RES. 1/6W J 100k Ω	RCX4JATZ0104 RCX6JATZ0104
R588	CARBON RES. 1/4W J 100k Ω or CARBON RES. 1/6W J 100k Ω	RCX4JATZ0104 RCX6JATZ0104
R589▲	CARBON RES. 1/4W J 47 Ω or ▲ CARBON RES. 1/6W J 47 Ω	RCX4JATZ0470 RCX6JATZ0470
R591▲	CHIP RES.(1608) 1/10W J 6.8k Ω	RRXAJB5Z0682
R592▲	CARBON RES. 1/4W J 180k Ω or ▲ CARBON RES. 1/6W J 180k Ω	RCX4JATZ0184 RCX6JATZ0184
R593▲	CHIP RES.(1608) 1/10W J 56k Ω	RRXAJB5Z0563
R594▲	CHIP RES.(1608) 1/10W J 56k Ω	RRXAJB5Z0563
R596	CARBON RES. 1/4W J 22k Ω or CARBON RES. 1/6W J 22k Ω	RCX4JATZ0223 RCX6JATZ0223
R597▲	CHIP RES.(1608) 1/10W J 6.8k Ω	RRXAJB5Z0682
R598▲	CHIP RES.(1608) 1/10W J 22k Ω	RRXAJB5Z0223
R599▲	CHIP RES.(1608) 1/10W J 10k Ω	RRXAJB5Z0103
R602▲	CEMENT RES. 3W J 1.2 Ω or ▲ CEMENT RES. 5W K 1.2 Ω or ▲ CEMENT RESISTOR 5W K 1.2 Ω or ▲ CEMENT RESISTOR 5W J 1.2 Ω	RW031R2PG007 RW051R2DP005 RW051R2PG001 RW051R2Y4001
R603▲	METAL OXIDE FILM RES. 2W J 0.39 Ω or ▲ METAL OXIDE FILM RES. 2W J 0.39 Ω	RN02R39ZU001 RN02R39DP004
R604▲	CARBON RES. 1/4W J 1.5M Ω or ▲ CARBON RES. 1/6W J 1.5M Ω	RCX4JATZ0155 RCX6JATZ0155
R605	CHIP RES.(1608) 1/10W J 1.2M Ω	RRXAJB5Z0125
R606	CARBON RES. 1/4W J 220 Ω or CARBON RES. 1/6W J 220 Ω	RCX4JATZ0221 RCX6JATZ0221
R607	CARBON RES. 1/4W J 180 Ω or CARBON RES. 1/6W J 180 Ω	RCX4JATZ0181 RCX6JATZ0181
R608	CARBON RES. 1/4W J 220k Ω or CARBON RES. 1/6W J 220k Ω	RCX4JATZ0224 RCX6JATZ0224
R609	PCB JUMPER D0.6-P5.0	JW5.0T
R610	CARBON RES. 1/4W J 1k Ω or CARBON RES. 1/6W J 1k Ω	RCX4JATZ0102 RCX6JATZ0102
R613	CARBON RES. 1/4W J 150 Ω or CARBON RES. 1/6W J 150 Ω	RCX4JATZ0151 RCX6JATZ0151
R614	CHIP RES.(1608) 1/10W J 2.2k Ω	RRXAJB5Z0222
R616▲	CARBON RES. 1/4W 2.2 Ω J or ▲ CARBON RES. 1/6W J 2.2 Ω	RCX4JATZ02R2 RCX6JATZ02R2
R617	CARBON RES. 1/4W J 180 Ω or CARBON RES. 1/6W J 180 Ω	RCX4JATZ0181 RCX6JATZ0181
R618	CARBON RES. 1/4W J 270 Ω or CARBON RES. 1/6W J 270 Ω	RCX4JATZ0271 RCX6JATZ0271

Ref. No.	Description	Part No.
R619	CARBON RES. 1/4W J 270 Ω or	RCX4JATZ0271
	CARBON RES. 1/6W J 270 Ω	RCX6JATZ0271
R620▲	CEMENT RES. 5W J 3.9k Ω or	RW05392DP008
▲	CEMENT RES. 5W 3.9k Ω H=25MM or	RW05392PG004
▲	CEMENT RES. 5W J 3.9k Ω	RW05392Y4004
R621▲	CARBON RES. 1/4W J 12k Ω or	RCX4JATZ0123
▲	CARBON RES. 1/6W J 12k Ω	RCX6JATZ0123
R622	CARBON RES. 1/4W J 12k Ω or	RCX4JATZ0123
	CARBON RES. 1/6W J 12k Ω	RCX6JATZ0123
R623	CARBON RES. 1/4W J 33k Ω or	RCX4JATZ0333
	CARBON RES. 1/6W J 33k Ω	RCX6JATZ0333
R624▲	CARBON RES. 1/4W J 39k Ω or	RCX4JATZ0393
▲	CARBON RES. 1/6W J 39k Ω	RCX6JATZ0393
R625▲	CARBON RES. 1/4W J 39k Ω or	RCX4JATZ0393
▲	CARBON RES. 1/6W J 39k Ω	RCX6JATZ0393
R629▲	CARBON RES. 1/4W J 10k Ω or	RCX4JATZ0103
▲	CARBON RES. 1/6W J 10k Ω	RCX6JATZ0103
R630▲	CARBON RES. 1/4W J 12k Ω or	RCX4JATZ0123
▲	CARBON RES. 1/6W J 12k Ω	RCX6JATZ0123
R631▲	CARBON RES. 1/4W J 15k Ω or	RCX4JATZ0153
▲	CARBON RES. 1/6W J 15k Ω	RCX6JATZ0153
R632▲	CARBON RES. 1/4W J 560 Ω or	RCX4JATZ0561
▲	CARBON RES. 1/6W J 560 Ω	RCX6JATZ0561
R633▲	CHIP RES.(1608) 1/10W J 5.6k Ω	RRXAJB5Z0562
R634	CHIP RES.(1608) 1/10W J 6.8k Ω	RRXAJB5Z0682
R635	CHIP RES.(1608) 1/10W J 10k Ω	RRXAJB5Z0103
R639▲	METAL OXIDE FILM RES. 2W J 680 Ω or	RN02681ZU001
▲	METAL OXIDE FILM RES. 2W J 680 Ω	RN02681DP004
R640▲	CHIP RES.(1608) 1/10W J 56k Ω	RRXAJB5Z0563
R641	CARBON RES. 1/4W J 10k Ω or	RCX4JATZ0103
	CARBON RES. 1/6W J 10k Ω	RCX6JATZ0103
R642	CHIP RES.(1608) 1/10W J 5.6k Ω	RRXAJB5Z0562
R644	CARBON RES. 1/4W J 47k Ω or	RCX4JATZ0473
	CARBON RES. 1/6W J 47k Ω	RCX6JATZ0473
R645▲	CARBON RES. 1/4W J 220 Ω or	RCX4JATZ0221
▲	CARBON RES. 1/6W J 220 Ω	RCX6JATZ0221
R646▲	METAL OXIDE FILM RES. 1W J 47 Ω or	RN01470ZU001
▲	METAL OXIDE FILM RES. 1W J 47 Ω	RN01470DP003
R647▲	METAL OXIDE FILM RES. 1W J 47 Ω or	RN01470ZU001
▲	METAL OXIDE FILM RES. 1W J 47 Ω	RN01470DP003
R648▲	CARBON RES. 1/2W J 5.6 Ω or	RCX2JZQZ05R6
▲	CARBON RES. 1/2W J 5.6 Ω or	RCX25R6KA013
▲	CARBON RES. 1/2W J 5.6 Ω	RCX2JZPZ05R6
R649	CARBON RES. 1/4W J 68k Ω or	RCX4JATZ0683
	CARBON RES. 1/6W J 68k Ω	RCX6JATZ0683
R650▲	CARBON RES. 1/4W J 22 Ω or	RCX4JATZ0220
▲	CARBON RES. 1/6W J 22 Ω	RCX6JATZ0220
R651▲	CARBON RES. 1/4W J 560 Ω or	RCX4JATZ0561
▲	CARBON RES. 1/6W J 560 Ω	RCX6JATZ0561
R652▲	CARBON RES. 1/4W J 560 Ω or	RCX4JATZ0561
▲	CARBON RES. 1/6W J 560 Ω	RCX6JATZ0561
R653	CARBON RES. 1/4W J 100 Ω or	RCX4JATZ0101
	CARBON RES. 1/6W J 100 Ω	RCX6JATZ0101
R654▲	CARBON RES. 1/2W J 10 Ω or	RCX2JZQZ0100
▲	CARBON RES. 1/2W J 10 Ω or	RCX2100KA013
▲	CARBON RES. 1/2W J 10 Ω	RCX2JZPZ0100
R655▲	CARBON RES. 1/4W J 2.2k Ω or	RCX4JATZ0222
▲	CARBON RES. 1/6W J 2.2k Ω	RCX6JATZ0222
R656▲	METAL OXIDE FILM RES. 2W J 10 Ω or	RN02100ZU001
▲	METAL OXIDE FILM RES. 2W J 10 Ω	RN02100DP004
R659	CARBON RES. 1/4W J 100 Ω or	RCX4JATZ0101

Ref. No.	Description	Part No.
	CARBON RES. 1/6W J 100 Ω	RCX6JATZ0101
R660	PCB JUMPER D0.6-P5.0	JW5.0T
R665	PCB JUMPER D0.6-P5.0	JW5.0T
R701	CHIP RES.(1608) 1/10W J 82 Ω	RRXAJB5Z0820
R801▲	METAL OXIDE FILM RES. 1W J 12 Ω or	RN01120ZU001
▲	FIXED METAL OXIDE FILM RES. 1W J 12 Ω	RN01JZPZ0120
R802▲	CHIP RES.(1608) 1/10W J 4.7k Ω	RRXAJB5Z0472
R803▲	CHIP RES.(1608) 1/10W J 2.2k Ω	RRXAJB5Z0222
R804	CARBON RES. 1/4W J 2.7k Ω or	RCX4JATZ0272
	CARBON RES. 1/6W J 2.7k Ω	RCX6JATZ0272
R805	CARBON RES. 1/4W J 10k Ω or	RCX4JATZ0103
	CARBON RES. 1/6W J 10k Ω	RCX6JATZ0103
R806	CARBON RES. 1/4W J 47 Ω or	RCX4JATZ0470
	CARBON RES. 1/6W J 47 Ω	RCX6JATZ0470
R807	CARBON RES. 1/4W J 47 Ω or	RCX4JATZ0470
	CARBON RES. 1/6W J 47 Ω	RCX6JATZ0470
R851	CHIP RES.(1608) 1/10W J 22k Ω	RRXAJB5Z0223
R852	CHIP RES.(1608) 1/10W J 3.3k Ω	RRXAJB5Z0332
R853	CHIP RES.(1608) 1/10W J 2.2M Ω	RRXAJB5Z0225
R856	CHIP RES.(1608) 1/10W J 22k Ω	RRXAJB5Z0223
R857	CHIP RES.(1608) 1/10W J 3.3k Ω	RRXAJB5Z0332
R858	CHIP RES.(1608) 1/10W J 6.8k Ω	RRXAJB5Z0682
R859	CHIP RES.(1608) 1/10W J 4.7k Ω	RRXAJB5Z0472
R861	CHIP RES.(1608) 1/10W J 6.8k Ω	RRXAJB5Z0682
R862	CHIP RES.(1608) 1/10W J 2.7k Ω	RRXAJB5Z0272
R863	CHIP RES.(1608) 1/10W J 10k Ω	RRXAJB5Z0103
R864	CHIP RES.(1608) 1/10W J 8.2k Ω	RRXAJB5Z0822
R865	CHIP RES.(1608) 1/10W J 12k Ω	RRXAJB5Z0123
R866	CHIP RES.(1608) 1/10W J 330k Ω	RRXAJB5Z0334
R867	CHIP RES.(1608) 1/10W J 150 Ω	RRXAJB5Z0151
R868	CHIP RES.(1608) 1/10W J 22k Ω	RRXAJB5Z0223
R869	CHIP RES.(1608) 1/10W J 820 Ω	RRXAJB5Z0821
R871	CARBON RES. 1/4W J 1k Ω or	RCX4JATZ0102
	CARBON RES. 1/6W J 1k Ω	RCX6JATZ0102
R872	CHIP RES.(1608) 1/10W J 22k Ω	RRXAJB5Z0223
R873	CARBON RES. 1/4W J 47k Ω or	RCX4JATZ0473
	CARBON RES. 1/6W J 47k Ω	RCX6JATZ0473
R874	CARBON RES. 1/4W J 100 Ω or	RCX4JATZ0101
	CARBON RES. 1/6W J 100 Ω	RCX6JATZ0101
R875	CHIP RES.(1608) 1/10W J 2.2k Ω	RRXAJB5Z0222
R876	CHIP RES.(1608) 1/10W J 2.2k Ω	RRXAJB5Z0222
R877	CARBON RES. 1/4W J 820 Ω or	RCX4JATZ0821
	CARBON RES. 1/6W J 820 Ω	RCX6JATZ0821
SWITCHES		
SW201	TACT SWITCH SKQSAB or	SST0101AL038
	TACT SWITCH SKHHAM or	SST0101AL029
	TACT SWITCH KSM0612B	SST0101HH003
SW202	TACT SWITCH SKQSAB or	SST0101AL038
	TACT SWITCH SKHHAM or	SST0101AL029
	TACT SWITCH KSM0612B	SST0101HH003
SW203	TACT SWITCH SKQSAB or	SST0101AL038
	TACT SWITCH SKHHAM or	SST0101AL029
	TACT SWITCH KSM0612B	SST0101HH003
SW204	TACT SWITCH SKQSAB or	SST0101AL038
	TACT SWITCH SKHHAM or	SST0101AL029
	TACT SWITCH KSM0612B	SST0101HH003
SW205	TACT SWITCH SKQSAB or	SST0101AL038
	TACT SWITCH SKHHAM or	SST0101AL029
	TACT SWITCH KSM0612B	SST0101HH003
SW206	TACT SWITCH SKQSAB or	SST0101AL038

Ref. No.	Description	Part No.
	TACT SWITCH SKHHAM or	SST0101AL029
	TACT SWITCH KSM0612B	SST0101HH003
SW207	TACT SWITCH SKQSAB or	SST0101AL038
	TACT SWITCH SKHHAM or	SST0101AL029
	TACT SWITCH KSM0612B	SST0101HH003
SW208	TACT SWITCH SKQSAB or	SST0101AL038
	TACT SWITCH SKHHAM or	SST0101AL029
	TACT SWITCH KSM0612B	SST0101HH003
SW209	TACT SWITCH SKQSAB or	SST0101AL038
	TACT SWITCH SKHHAM or	SST0101AL029
	TACT SWITCH KSM0612B	SST0101HH003
SW210	TACT SWITCH SKQSAB or	SST0101AL038
	TACT SWITCH SKHHAM or	SST0101AL029
	TACT SWITCH KSM0612B	SST0101HH003
SW211	LEAF SWITCH LSA-1142AU or	SSC0101KB013
	LEAF SWITCH MXS00052MPP0 or	SSC0101MCE01
	LEAF SWITCH MXS00981MPP0	SSC0101MCE02
SW212	ROTARY MODE SWITCH SSS-43MD or	SSR0106KB001
	ROTARY MODE SWITCH R8100212	SSR0106U3001
MISCELLANEOUS		
BC571	BEAD INDUCTORS FBA04HA600VB-00	LLBF00STU026
BC601	BEAD INDUCTORS FBR07HA121TB-00	LLBF00ZTU021
BC602	BEAD INDUCTORS FBR07HA121TB-00	LLBF00ZTU021
BC603	BEAD INDUCTORS FBR07HA121TB-00	LLBF00ZTU021
BC604	BEAD INDUCTORS FBR07HA121TB-00	LLBF00ZTU021
BC605	BEAD INDUCTORS FBR07HA121TB-00	LLBF00ZTU021
BC606	PCB JUMPER D0.6-P5.0	JW5.0T
CF301	CERAMIC TRAP 4.5MHz or	FBE455PMR003
	4.5M TRAP XT4.5MB2	FBE455PLN001
CF302	CERAMIC FILTER SFSRA4M50CF00-B0 or	FBB455PMR004
	4.5M FILTER LTH4.5MCB	FBB455PLN001
CL201	FFC/FPC CONNECTOR 12P 04 6232 112 103 800	JC62D12TM003
F601▲	FUSE 4.00A/125V or	PAGU20CAG402
▲	FUSE 51MS040L or	PAFC20CHV402
▲	FUSE 4A/125V 237 TYPE or	PAGJ20CAG402
▲	FUSE STC4A125V U/CT	PAGE20CW3402
FH601	FUSE HOLDER MSF-015	XH01Z00LY001
FH601▲	FUSE HOLDER FH-V-03078	XH01Z00DK001
FH602	FUSE HOLDER MSF-015	XH01Z00LY001
FH602▲	FUSE HOLDER FH-V-03078	XH01Z00DK001
J023	CARBON RES. 1/4W J 1k Ω or	RCX4JATZ0102
	CARBON RES. 1/6W J 1k Ω	RCX6JATZ0102
JK701	RCA JACK(YELLOW) MSP-281V4-B or	JXRL010LY003
	RCA JACK(YELLOW) AV1-15-3	JXRL010RP013
JK702	RCA JACK(WHITE) MSP-281V1-B or	JXRL010LY005
	RCA JACK(WHITE) AV1-15-4	JXRL010RP014
JK801	EARPHONE JACK MSJ-035-12APC or	JYSL030LY001
	EARPHONE JACK HTJ-035-1ZEBTZ or	JYSL030GE001
	EARPHONE JACK HSJ1403-01-010	JYSL030HD002
PS601▲	THERMISTOR ZPB45BL7R0A	QNZ245BL7R0A
RS201	REMOTE RECEIVER MIM-93M6DKF or	USESJRSUNT01
	REMOTE RECEIVER PIC-37042LU	USESJRSK033
SA601▲	SURGE ABSORBER JVR-07N471K or	NVQZVR07N471
▲	SURGE ABSORBER CNR-10D471K or	NVQZR10D471K
▲	SURGE ABSORBER CNR-07D471K or	NVQZR07D471K
▲	SURGE ABSORBER PVR-07D471KB	NVQZ07D471KB
SF001	SAW FILTER SAFGP45M7VHEZM0B03	FBB456PMR005
SG601▲	GAP. FNR-G3.10D	FAZ000LD6005
T571▲	FLYBACK TRANS BSC21-2028S	LTF00CPS2046
T572	HORIZONTAL DRIVE TRANS LP2-005	LTH00CPA5005

Ref. No.	Description	Part No.
T601▲	SWITCHING TRANS 01746 or	LTT00CPKT089
▲	SWICHING TRANS CSA-SW0041	LTT00CPSA117
TB3	HEAD SHIELD(NTSC) T5300UA	0EM301560
TB7	LED HOLDER T5300UA	0EM406868
TB9	13VPOW HEAT SINK PGD ASSEMBLY T5300UA	0EM406798
TB21	BUSH, LED(F) H3700UD	0VM409508
TB26	13V H/V HEAT SINK PGF T5300UA	0EM406799
TL2	SCREW, B-TIGHT M3X8 BIND HEAD+ or	GBMB3080
	SCREW, B-TIGHT M3X8 BIND HEAD+	GBMB3080
TU001▲	TUNER UNIT TEDH-932A	UTUNNTUAL029
VR601▲	CARBON P.O.T. 10k Ω B or	VRCB103KA011
▲	CARBON P.O.T. 10k Ω B	VRCB103HH014
W601▲	AC CORD PB8K9F9110A-057 or	WAC0172LW008
▲	AC CORD WAC0172LTE01 or	WAC0172LTE01
▲	AC CORD WAC0172AS006	WAC0172AS006
X201	XTAL 32.768kHz(20PPM) or	FXC323LJNY01
	XTAL 32.768kHz(20PPM) or	FXC323LCT001
	XTAL 32.768kHz(20PPM)	FXC323LDS002
X202	XTAL HC-49/U 10.6MHz or	FXD106LDS001
	XTAL AT49-10.6 or	FXD106LDS002
	XTAL :10.6MHz S8562	FXD106LCT001
X301	XTAL 3.579545 MHz	FXD355LLN003
X401	XTAL 3.579545MHz(20PPM) or	FXC355LJNY01
	XTAL 3.579545MHz(20PPM) or	FXC355LLN003
	XTAL 3.579545MHz(20PPM) or	FXC355LDS001
	XTAL 3.579545MHz	FXC355LLN001

CRT CBA

Ref. No.	Description	Part No.
	CRT CBA (MMA-B) Consists of the followings	-----
CAPACITORS		
C501	CHIP CERAMIC CAP. CH J 330pF/50V	CHD1JJBCH331
C502	CHIP CERAMIC CAP. CH J 330pF/50V	CHD1JJBCH331
C503	CHIP CERAMIC CAP. CH J 330pF/50V	CHD1JJBCH331
C507	ELECTROLYTIC CAP. 47μF/25V M or	CE1EMASDL470
	ELECTROLYTIC CAP. 47μF/25V M	CE1EMASTL470
C510	CERAMIC CAP. B K 1000pF/2KV or	CCD3DKP0B102
	CERAMIC CAP. B K 1000pF/2KV or	CA3D102MR030
	CERAMIC CAP. B K 1000pF/2KV	CCD3DKD0B102
CONNECTORS		
CN501	PIN CONNECTOR 005P-5100 or	JTEA001TG001
	CONNECTOR PIN, 1P LV or	1700576
	CONNECTOR PIN, 1P RT-01N-2.3A	1730688
COIL		
L501	PCB JUMPER D0.6-P5.0	JW5.0T
TRANSISTORS		
Q501	TRANSISTOR 2SC2482 TPE6 or	QQSZ02SC2482
	TRANSISTOR 2SC3468(E)-AE or	QQSE02SC3468
	TRANSISTOR 2SC3468(D)-AE or	QQSD02SC3468
	TRANSISTOR KTC3207	NQSZ0KTC3207
Q502	TRANSISTOR 2SC2482 TPE6 or	QQSZ02SC2482
	TRANSISTOR 2SC3468(E)-AE or	QQSE02SC3468
	TRANSISTOR 2SC3468(D)-AE or	QQSD02SC3468
	TRANSISTOR KTC3207	NQSZ0KTC3207
Q503	TRANSISTOR 2SC2482 TPE6 or	QQSZ02SC2482
	TRANSISTOR 2SC3468(E)-AE or	QQSE02SC3468
	TRANSISTOR 2SC3468(D)-AE or	QQSD02SC3468
	TRANSISTOR KTC3207	NQSZ0KTC3207
RESISTORS		

Ref. No.	Description	Part No.
R501▲	METAL OXIDE FILM RES. 1W J 15k Ω or	RN01153ZU001
▲	METAL OXIDE FILM RES. 1W J 15k Ω	RN01153DP003
R502▲	METAL OXIDE FILM RES. 1W J 15k Ω or	RN01153ZU001
▲	METAL OXIDE FILM RES. 1W J 15k Ω	RN01153DP003
R503▲	METAL OXIDE FILM RES. 1W J 15k Ω or	RN01153ZU001
▲	METAL OXIDE FILM RES. 1W J 15k Ω	RN01153DP003
R504	CARBON RES. 1/4W J 1.5k Ω	RCX4JATZ0152
R505	CARBON RES. 1/4W J 1.5k Ω	RCX4JATZ0152
R506	CARBON RES. 1/4W J 1.5k Ω	RCX4JATZ0152
R507	CARBON RES. 1/4W J 1.5k Ω	RCX4JATZ0152
R508	CARBON RES. 1/4W J 1.5k Ω	RCX4JATZ0152
R511▲	CARBON RES. 1/4W J 150k Ω	RCX4JATZ0154
R512▲	CARBON RES. 1/4W J 150k Ω	RCX4JATZ0154
R513▲	CARBON RES. 1/4W J 150k Ω	RCX4JATZ0154
R514	CARBON RES. 1/4W J 1.5k Ω	RCX4JATZ0152
R516	CHIP RES.(1608) 1/10W J 15 Ω	RRXAJB5Z0150
R517	CARBON RES. 1/4W J 680 Ω or	RCX4JATZ0681
	CARBON RES. 1/6W J 680 Ω	RCX6JATZ0681
R518	CHIP RES.(1608) 1/10W J 15 Ω	RRXAJB5Z0150
R519	CARBON RES. 1/4W J 680 Ω or	RCX4JATZ0681
	CARBON RES. 1/6W J 680 Ω	RCX6JATZ0681
R520	CHIP RES.(1608) 1/10W J 15 Ω	RRXAJB5Z0150
R521	CARBON RES. 1/4W J 680 Ω or	RCX4JATZ0681
	CARBON RES. 1/6W J 680 Ω	RCX6JATZ0681
MISCELLANEOUS		
CL501A	LEAD WIRE 3P/270	WX1T5300-101
CL504A	LEAD WIRE 4P/250	WX1T5300-102
JK501▲	CRT SOCKET ISMS02S	JSCC220PK003

SENSOR CBA

Ref. No.	Description	Part No.
	SENSOR CBA Consists of the followings	0ESA04524
TRANSISTORS		
Q201	PHOTO TRANSISTOR PT204-6B-12 or	NPWZT2046B12
	PHOTO TRANSISTOR MID-32A22	NPWZM1D32A22
Q202	PHOTO TRANSISTOR PT204-6B-12 or	NPWZT2046B12
	PHOTO TRANSISTOR MID-32A22	NPWZM1D32A22

DECK PARTS LIST

Note: There are two different, but interchangeable types of CLEANER LEVER(B359) in this model, and have different combination with B361. Please see Table 1 for details and combination.

Table 1 (B359 and B361 Combination)

B359 CLEANER LEVER		B361
Type	ID No.	ID No.
A	OVM304413	OVM411114
B	OVM305090	Not used

Ref.No	Description	Part No.
B2	CYLINDER ASSEMBLY MK11 NTSC 4HD SQPB	N1448CYL
B3	LOADING MOTOR ASSEMBLY MK11	OVSA12093
B8	PULLEY ASSEMBLY MK11	OVSA12078
B9	MOVING GUIDE S PREPARATION MK10	OVSA11002
B10	MOVING GUIDE T PREPARATION MK10	OVSA11004
B11	LOADING ARM T(B) ASSEMBLY MK11	OVSA12110
B12	LOADING ARM S(B) ASSEMBLY MK11	OVSA12109
B27	TENSION LEVER SUB ASSEMBLY MK11	OVSA12076
B31	AC HEAD ASSEMBLY MK11(TVCR)	OVSA12305
B35	TAPE GUIDE ASSEMBLY MK11	OVSA12069
B37	CAPSTAN MOTOR 288/VCCM011	N9660CMT
B52	CAP BELT MK10	OVM411138
B73	FE HEAD ASSEMBLY MK11 or	N9742FEL
	FE HEAD(MK11) MH-131SF11 or	DHVEC01Z0005
	FE HEAD ASSEMBLY MK11	N9743FEL
B74	PRISM MK10	OVM202870
B121	WORM MK11	OVM412544
B126	PULLEY MK11	OVM412543
B133	IDLER ASSEMBLY MK10	OVSA11017
B148	TG CAP MK11	OVM412972
B300	C DRIVE LEVER R MK11	OVM305068
B303	F DOOR OPENER MK11	OVM203299
B347	GUIDE HOLDER A MK10	OVM304920
B354	SLIDER R MK11	OVM101040
B355	SLIDER L MK11	OVM203296
B359	CLEANER LEVER MK10 or	OVM304413
	CLEANER LEVER MK11	OVM305090
B360	CLEANER ROLLER MK9	OVM410032C
B361	CL POST MK10	OVM411114
B410	PINCH ARM(A) ASSEMBLY MK11	OVSA12064
B411	PINCH SPRING MK10	OVM411092
B414	M BRAKE S ASSEMBLY MK11	OVSA12211
B416	M BRAKE T ASSEMBLY MK11	OVSA12212
B417	TENSION SPG(190265) MK11	OVM412984
B425	LOCK LEVER SPRING MK10	OVM411110
B426	KICK PULLEY MK10	OVM411095
B482	C PLATE MK11	OVM203297
B483	LOCK LEVER MK10	OVM411109D
B487	BAND BRAKE MK10	OVM304416B
B488	MODE LEVER MK11 or	OVM101043
	MODE LEVER(PB) MK11	OVM101112
B491	CAM GEAR(A) MK11	OVM101044
B492	MODE GEAR MK11	OVM305074
B494	DOOR OPENER B MK11	OVM305072

Ref.No	Description	Part No.
B499	T LEVER HOLDER MK10	OVM304419
B501	WORM HOLDER MK11	OVM305067
B502	CAM GEAR(B) MK10	OVM304403
B505	PSCW(625504) MK11	OVM413288
B507	REEL WASHER MK9 5*2.1*0.5	OVM410058
B508	S BRAKE SPRING MK10	OVM411121
B513	PSCW(752605) MK10	OVM411516
B514	SCREW RACK MK11	OVM412597
B516	REEL WASHER MK9 5*2.1*0.5	OVM410058
B518	P.S.W CUT 1.6X4.0X0.5T	OVM408485A
B520	T BRAKE SPRING MK10	OVM411123
B521	SOFT SPRING MK10	OVM411122
B522	TG POST ASSEMBLY MK11	OVSA12080
B525	LDG BELT MK11	OVM412804
B529	CLEANER ASSEMBLY MK11	OVSA12086
B551	FF ARM MK11	OVM305069
B553	REV SPRING MK11	OVM412555
B555	RACK ASSEMBLY MK11	OVSA12071
B557	MOTOR PULLEY U5	OVM403205A
B558	LOADING MOTOR M31E-1 R14 7351	MMDZB12MM002
B559	CLUTCH ASSEMBLY MK11	OVSA12350
B560	KICK SPRING MK10	OVM411475A
B562	C DRIVE LEVER L MK10	OVM304408
B563	SLIDER SHAFT MK10	OVM411112
B564	M GEAR MK10	OVM411136E
B565	SENSOR GEAR MK11	OVM305080
B567	PINCH ARM(B) MK10	OVM304396
B568	BT ARM MK10	OVM304417H
B569	CAM HOLDER F MK11	OVM305075
B570	CAM RACK SPG MK10	OVM411102
B571	P.S.W F 6*2.55*0.5	OVM402629A
B572	P.S.W CUT 1.6X4.0X0.5T	OVM408485A
B573	REEL S MK11	OVM203436
B574	REEL T MK10	OVM202872C
B585	PSW(2957505) MK11	OVM412745
L1051	SCREW, B-TIGHT M2.6X6 PAN HEAD+	GPMB9060
L1053	SCREW, S-TIGHT M2.6X8 WASHER HEAD+	GCMS9080
L1151	SCREW, SEMS M2.6X4 PAN HEAD+	CPM39040
L1191	SCREW, S-TIGHT M2.6X8 WASHER HEAD+	GCMS9080
L1321	SCREW, S-TIGHT M3X6 BIND HEAD+	GBMS3060
L1341	SCREW, P-TIGHT M2.6X6 BIND HEAD+	GBMP9060
L1406	AC HEAD SCREW MK9	OVM410964
L1450	SCREW, SEMS M2.6X5 PAN HEAD+	CPM39050
L1461	SCREW, P-TIGHT M2.6X6 WASHER HEAD+	GCMP9060
L1466	SCREW, S-TIGHT M2.6X6 BIND HEAD+	GBMS9060
L1467	SCREW, S-TIGHT M2.6X5 WASHER HEAD+	GCMS9050
L1468	SCREW, B-TIGHT M1.7X12	GAMB7120

